

# Power Brake Units

## BENDIX MASTER VAC

Dodge (M300)

NOTE — For other units used, see Power Brake Index.

### DESCRIPTION

Power brake unit is a dual diaphragm type, mounted on frame rail. Unit is actuated by brake pedal through a pedal link. Vacuum is supplied by a line connected to intake manifold. Vacuum line is connected at unit through a check valve. Master cylinder push rod is integral with power brake unit.

### REMOVAL & INSTALLATION

**Removal** — Disconnect brake lines at master cylinder. Remove master cylinder from power brake unit. Disconnect vacuum line from check valve and line to filter. Remove nut and bolt from unit push rod and lower brake pedal lever. Remove unit mounting nuts and separate unit from pedestal mount.

**Installation** — To install, reverse removal procedure. Bleed brake system. See *Hydraulic Brake Bleeding* in this Section.

### OVERHAUL

NOTE — Chrysler Corp. does not recommend overhaul of this unit. Replace unit if defective.

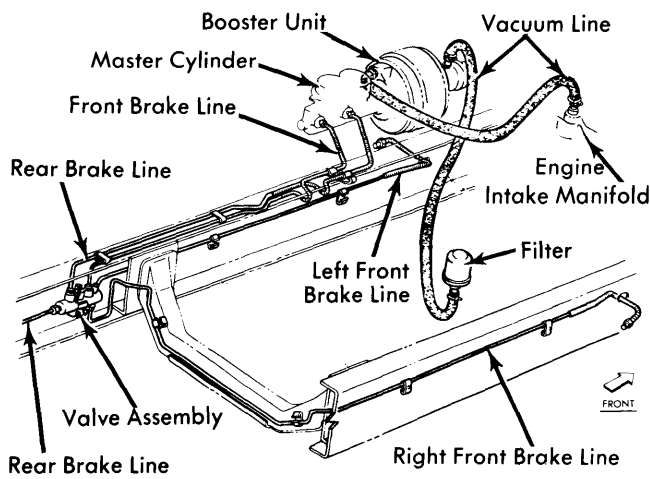

Fig. 1 Power Brake Unit Lines & Connections

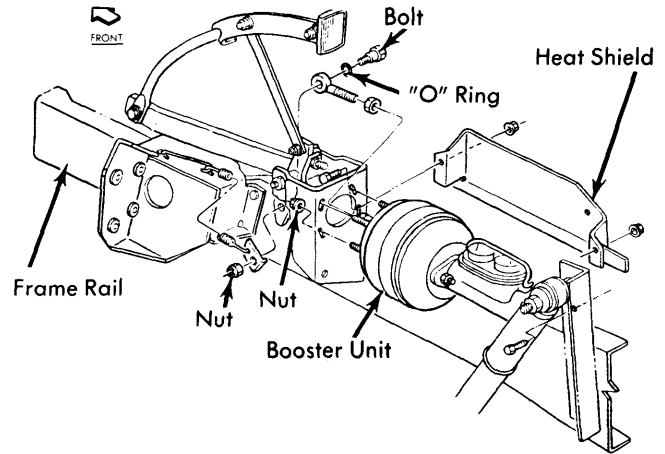

Fig. 2 Power Brake Unit Mounting