

CHRYSLER CORP.

"D", "AD", "PD" MODELS

Tie Rod End Removal – *NOTE* – Removal of tie rod ends from steering arm or center link by methods other than using Special Tool C-3894-A will damage tie rod end seal. Install suitable tie rod end puller (C-3894-A) and remove rod end by turning puller screw. Before installing, replace any seals that are damaged or worn.

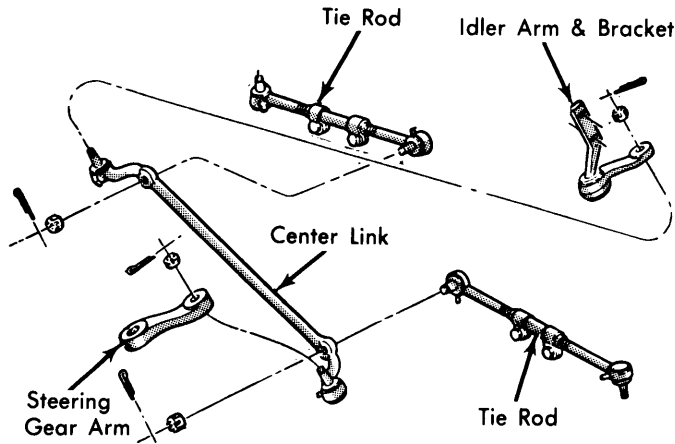

Fig. 1 Disassembled View of Steering Linkage for "D", "AD", and "PD" Models

"B" & "PB" MODELS

Ball Joints – Compression (tension) type lower ball joints are used on all models. Ball joints are of semi-permanent lubricated type except for vehicles used for off-highway operations. Lower ball joints should be replaced if axial end play exceeds .020".

Tie Rod End Removal – *NOTE* – Removal of tie rod ends from steering arm or center link by methods other than using Special Tool C-3894-A will damage tie rod end seal. Install suitable tie rod end puller (C-3894-A) and remove rod end by turning puller screw. Before installing, replace any seals that are damaged or worn.

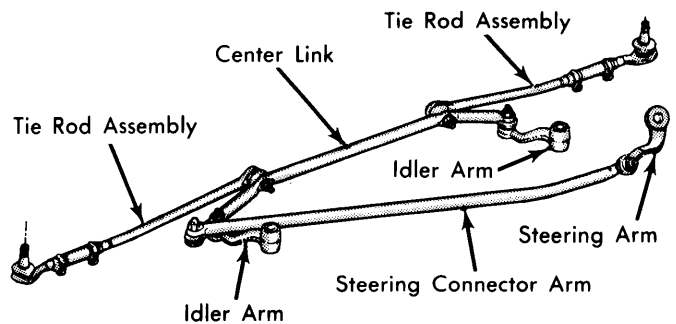

Fig. 3 Disassembled View of Steering Linkage for "B" and "PB" Models

"W", "AW", "PW" MODELS

Ball Joints – Steering linkage ball joint service is same as on two-wheel drive vehicles. See "D", "AD", "PD Models in this article. Servicing ball joints used on steering knuckles requires dismantling of knuckle. See *Open Steering Knuckles* in this Section.

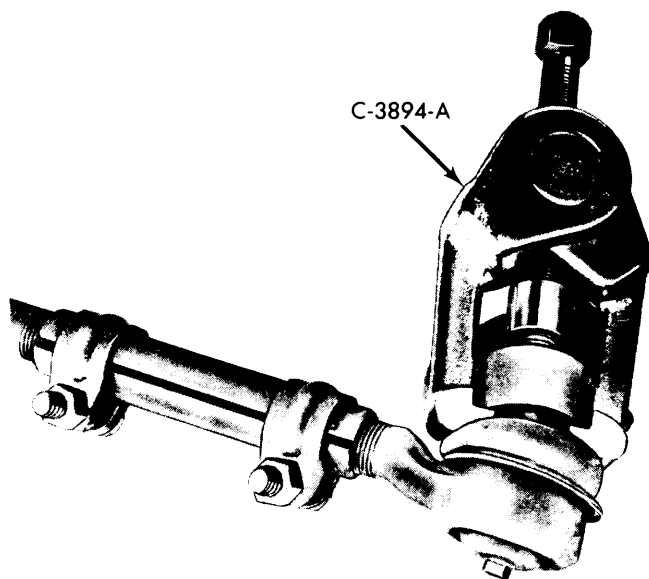

Fig. 2 Separating Tie Rod End Using Special Tool

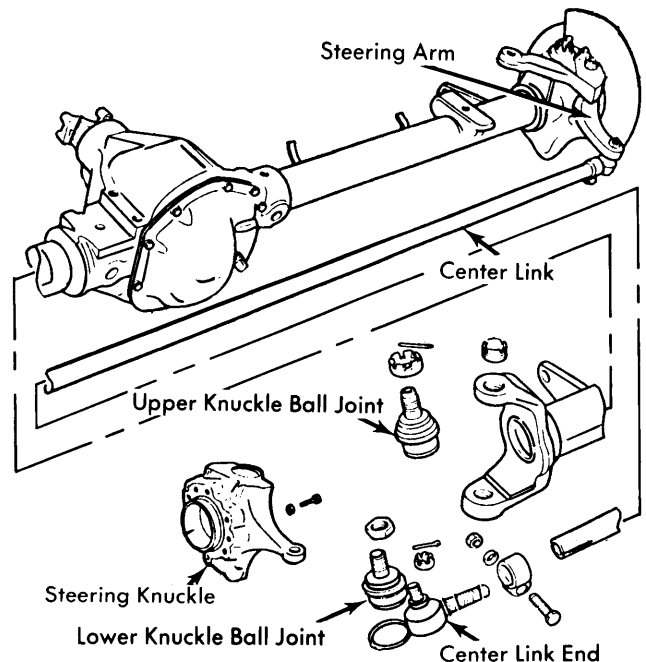
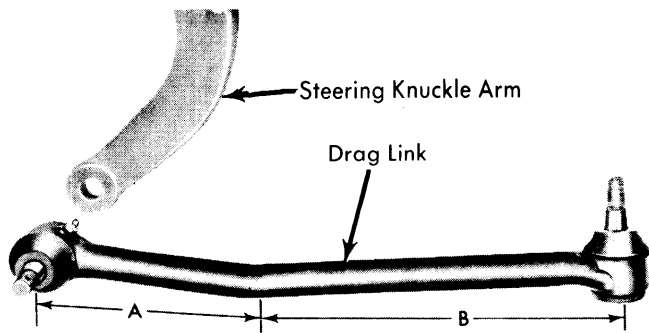

Fig. 4 Typical 4WD Steering Linkage Assembly (W100 is Model Being Shown)

Steering Linkage

CHRYSLER CORP (Cont.)



Drag Link – Drag link must be installed to steering knuckle arm with short half ("A") attaching to knuckle arm.

MOTOR HOME CHASSIS ("M" MODELS)

Servicing Components – Front axle assembly may be divided into four subassemblies: "I" beam axle, steering knuckles, steering linkage, and brake assemblies. It is not necessary to remove complete assembly to service steering linkage.

Fig. 5 Correctly Installing Drag Link for "W", "AW" and "PW" Models

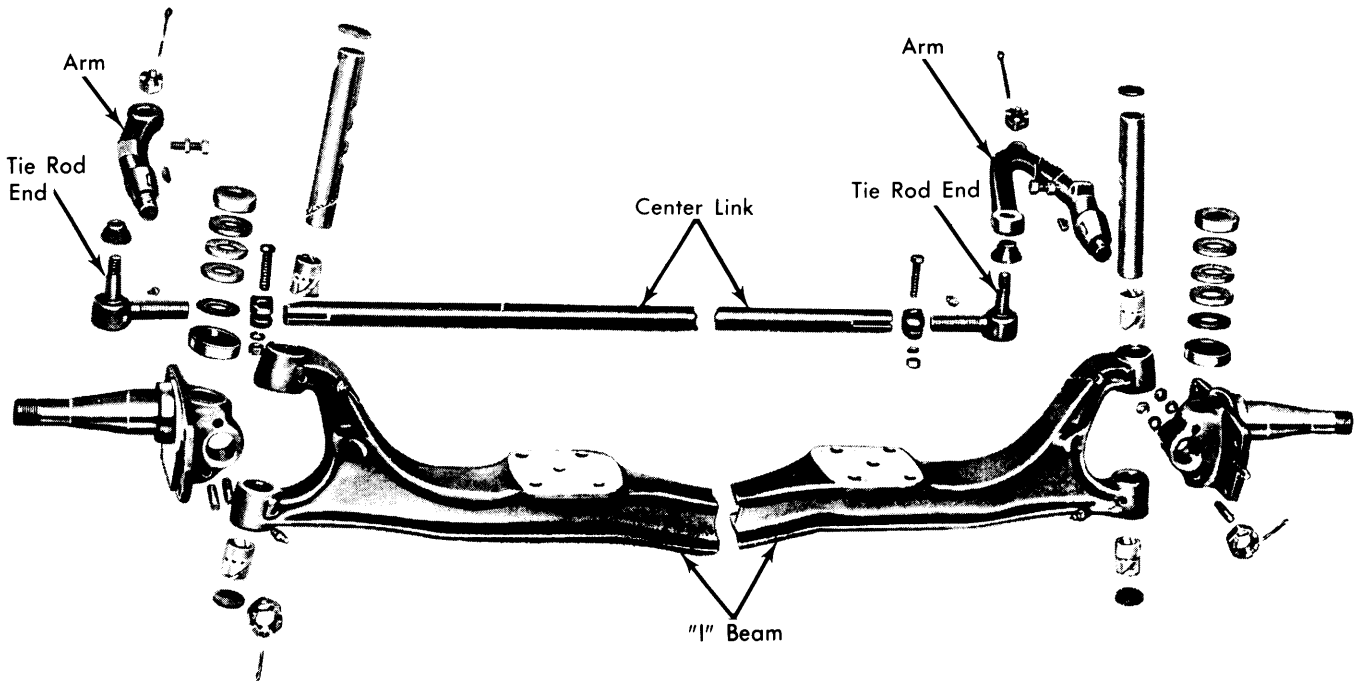

Fig. 6 Disassembled View of Motor Home Chassis Steering Linkage