

Brake Systems

FORD MOTOR CO. SINGLE ANCHOR

All Models

M-450 & M-500 (Front Only)

All Others (Rear Only)

DESCRIPTION

The single anchor duo servo brake assembly consists of a support plate, two brake shoes, return springs, automatic adjuster components and a wheel cylinder. On all models except M-450 and M-500, the automatic adjuster consists of a cable (with hook and anchor fitting), a cable guide, adjusting lever, adjusting screw, pivot nut, socket and spring. The automatic adjuster on M-450 and M-500 models consists of an adjusting lever link, a load limiting lever, adjusting lever, two springs, and adjusting screw. Both types of adjusters use movement of secondary shoe during reverse brake application to turn brake adjusting screw and maintain proper lining-to-drum clearance.

ADJUSTMENT & SERVICING

BRAKE SHOE ADJUSTMENT

All Models (Exc. M-450 & M-500) – 1) With brake drums at room temperature and parking brake correctly adjusted, remove brake drum. Using suitable tool (Rotunda 11-001 for 100, 150 and 250 series, and 11-002 for 350 series), measure inside diameter of brake drum. Hold automatic adjusting lever away from adjusting screw and turn screw until outside diameter of brake shoe surfaces, on a line parallel to vehicle and through center of axle, is equal to drum diameter.

2) Apply a small amount of lubricant at shoe-to-backing plate contact points. Install brake drum and wheel. Complete adjustment by applying brakes several times while driving vehicle in reverse. Check brake operation by making several stops while driving forward.

M-450 & M-500 – Raise vehicle until tire of brake being adjusted clears floor. Remove cover from adjusting hole. Turn adjusting screw through hole until brake shoes expand and lock drum. Now loosen until drum rotates with a slight drag, then back off screw 10 to 12 notches. Drum should rotate freely without drag.

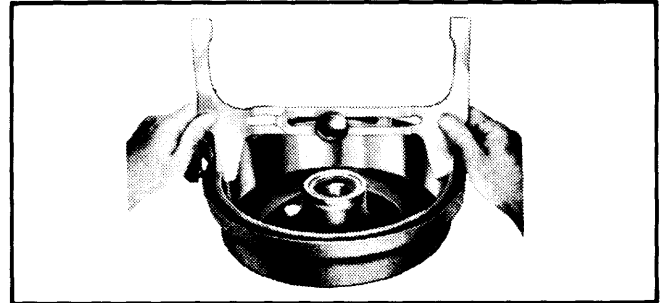

Fig. 1 Measuring Brake Drum Diameter

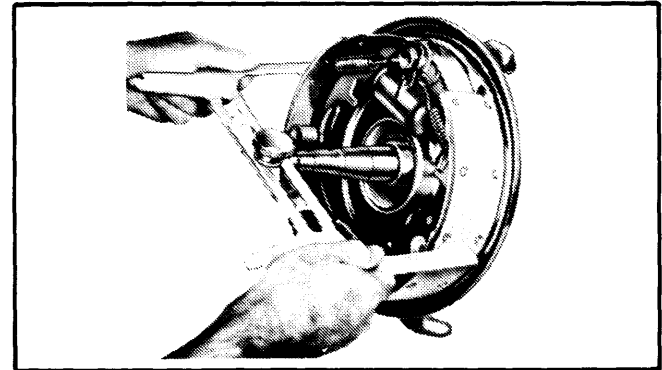

Fig. 2 Measuring Brake Shoe Diameter

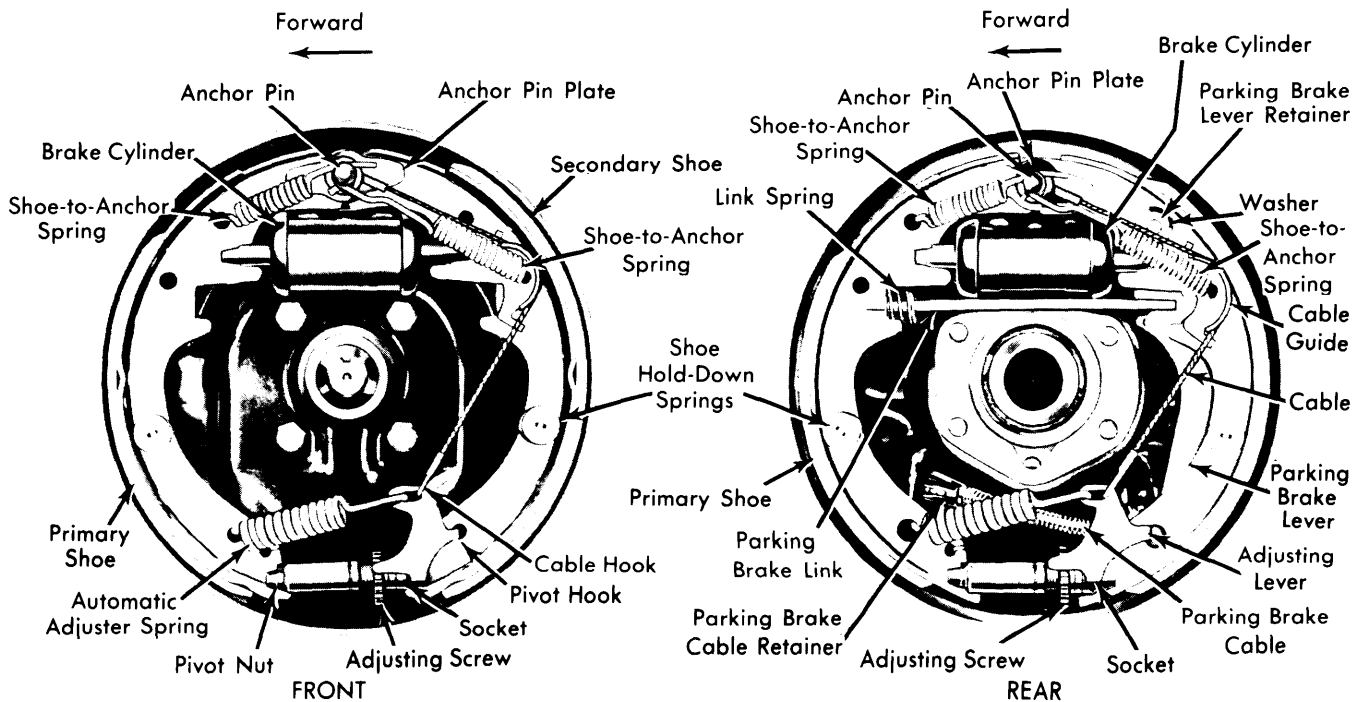

Fig. 3 Sectional View of Automatic Adjuster Brake Assembly
100, 150 and 250 Series (Up To 6900 GVW)

FORD MOTOR CO. SINGLE ANCHOR (Cont.)

PARKING BRAKE ADJUSTMENT

Cable Actuated Rear Wheel Type – Depress parking brake pedal two notches. Attach a tension gauge (S62F-1158) to the left cable. Now adjust cable until tension registered on gauge is 250 lbs. Now back off nut until tension gauge registers zero. Adjust cable until specified tension is registered on gauge.

Brake Cable Tension

Application	Tension
All "F" Models	100 Lbs.
All "E" Models	70 Lbs.
"U" Models.....	140 Lbs.

NOTE – For parking brake adjustment on M-450 and M-500 models, see Ford Motor Co. Dual Cylinder Duo Servo Brake System article in this Section.

BLEEDING SYSTEM

See Hydraulic Brake Bleeding in this Section.

REMOVAL & INSTALLATION

BRAKE SHOES

Removal (100, 150 & 250 Series Up To 6900 GVW) – 1) Remove wheel and drum and install clamp over ends of wheel cylinder. Disengage adjusting lever from adjusting screw by

pulling backward on lever. Move outboard side of adjusting screw up and back off pivot nut as far as possible. Pull adjusting lever, cable and automatic adjuster spring down and toward rear to unhook pivot hook from large hole in secondary shoe. **CAUTION** – Do Not pry pivot hook from hole.

Removal (Light Duty Models) – 1) Remove wheel and drum and install clamp over ends of wheel cylinder. Disengage adjusting lever from adjusting screw by pulling backward on lever. Move outboard side of adjusting screw up and back off pivot nut as far as possible. Pull adjusting lever, cable and automatic adjuster spring down and toward rear to unhook pivot hook from large hole in secondary shoe. **CAUTION** – Do not pry pivot hook from hole.

2) Remove automatic adjuster spring and adjusting lever. Remove shoe-to-anchor springs, cable anchor and anchor pin plate. Remove cable guide, shoe hold-down springs, shoes, adjusting screw, pivot nut and socket. On rear brakes, remove parking brake link and spring. Disconnect parking brake cable from lever, remove secondary shoe and disassemble parking brake lever from shoe by removing retaining clip and spring washer.

Installation – To install, reverse removal procedure, making sure: Adjusting cable is in groove of cable guide, cable does not bind on anchor pin and adjusting screw is mounted on correct side. If adjusting screw is mounted on wrong side, automatic adjuster will operate incorrectly.

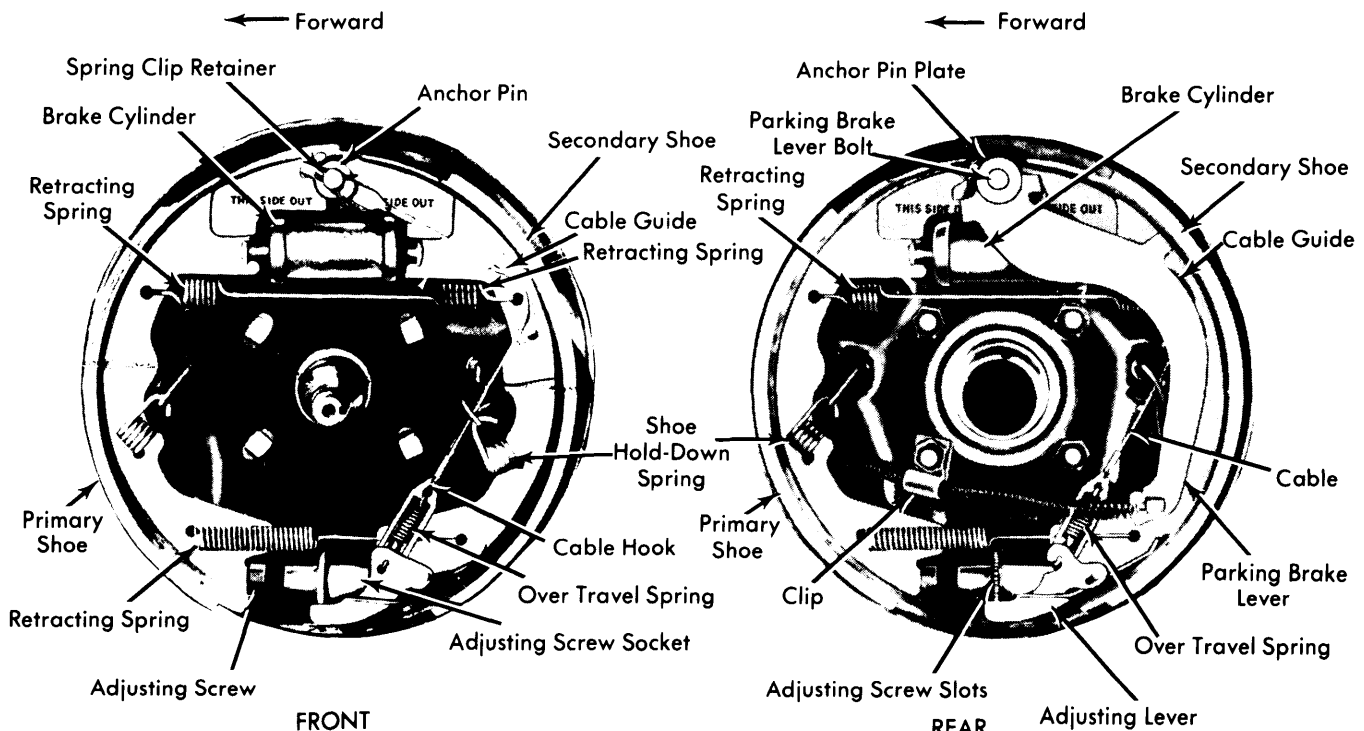

Fig. 4 Sectional View of Automatic Adjuster Brake Assembly 250 Series (over 6900 GVW) and 350 Series

Brake Systems

FORD MOTOR CO. SINGLE ANCHOR (Cont.)

Removal (250 Series Over 6900 GVW, 350 Series) – Remove wheel and brake drum. Remove parking brake lever assembly. Remove adjusting cable assembly from anchor pin, cable guide and adjusting lever. Remove brake shoe retracting springs, hold-down springs and brake shoes. Remove and disassemble adjusting screw assembly.

Installation – Apply a light coat of high temperature grease to contact points of brake assembly and reverse removal procedure.

Removal (M-450 & M-500) – Raise vehicle and remove wheel and drum. Remove shoe retracting springs from both sides. Remove adjusting lever link, anchor plate and lever spring. Remove shoe hold down spring cups and springs. Remove adjusting lever assembly. Remove brake shoes and adjuster assembly. Remove hold down pins from backing plate.

Installation – Apply a light coat of high temperature grease to contact points of brake assembly and reverse removal procedure.

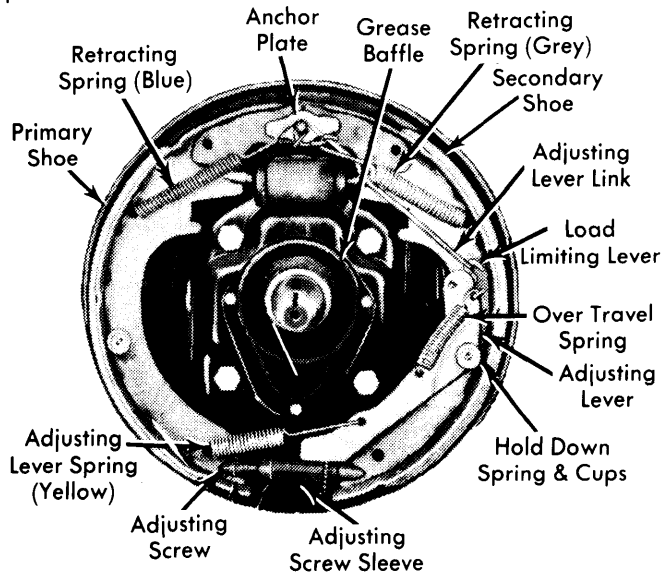

Fig. 5 Hydraulic Brake Assembly M-450 and M-500

WHEEL CYLINDER

Removal & Installation – Remove wheel, drum and brake shoes. Remove cylinder connecting links and disconnect hydraulic brake line from cylinder. Remove brake cylinder retaining bolts and remove cylinder from backing plate. To install, reverse removal procedure. Adjust brakes and bleed hydraulic system.

OVERHAUL

WHEEL CYLINDERS

Disassembly – With wheel cylinder removed from vehicle, remove rubber boots from ends of cylinders. Remove piston return spring, cylinder cups and piston from cylinder. Remove bleeder screw and inspect cylinder bore for damage.

Reassembly – If bore of cylinder is lightly pitted or scratched, hone or replace as necessary. Soak all parts in suitable brake fluid or assembly lubricant and reverse disassembly procedure. Clamp brake cylinder pistons against ends of cylinder.

TIGHTENING SPECIFICATIONS

Application	Ft. Lbs.
Front Backing Plate-to-Spindle	
3/16"-14	30-50
1/2"-13	55-70
1/2"-20	55-75
Rear Backing Plate-to-Axle	
3/16"-14	35-45
1/2"-13	75-105
1/2"-20	50-70
Hydraulic Tube Nuts	
3/8"-24	10-15
All Others	10-17

BRAKE SYSTEM SPECIFICATIONS

Application	Drum Diam.	Wheel Cylinder Diameter		Master Cylinder Diameter
		Front	Rear	
U-100 (Bronco)	11"	⊙	15/16"	1"
E-100 & 150	11"	⊙	15/16"	1"
E-250	11"	⊙	1"	1 1/4"
E-350	12"	⊙	1 1/16"	1 1/4"
F-100 & 150 (4x2)	11 1/32"	⊙	15/16"	1"
F-100 & 150 (4x4)	11"	⊙	15/16"	1"
F-250 (4x2 Up To 6900 GVW)	12 1/8"	⊙	15/16"	⊙1"
F-250 (4x2 Over 6900 GVW)	12"	⊙	1"	⊙1"
F-250 (4x4)	12 1/8"	⊙	1"	⊙1"
F-350	12 1/8"	⊙	1 1/16"	1 1/4"
M-450 & M-500	⊙ 14"

- ⊙ – Front disc brakes are standard equipment.
- ⊙ – 1 1/4" for models equipped with dual piston front calipers.