

IHC SLIDING CALIPER DISCS

International Harvester
Scout II, Terra & Traveler

DESCRIPTION

Sliding caliper disc brake assembly uses a single piston caliper mounted to an anchor bracket which is cast integrally with spindle. As brake pedal is depressed, hydraulic pressure is passed through a proportioning valve to brake caliper piston. This force is transmitted to inboard disc pad and against braking surface. As force increases against inboard side, caliper slides inward, providing vise-like clamping action on rotor.

ADJUSTMENT & SERVICING

DISC PAD ADJUSTMENT

Automatic adjustment is provided by outward relocation of piston as lining wears.

BLEEDING SYSTEM

See *Hydraulic Brake Bleeding in this Section.*

REMOVAL & INSTALLATION

BRAKE CALIPER & BRAKE PADS

Removal - 1) Remove front wheel. Position a large "C" clamp over caliper and tighten clamp so that piston will bottom in cylinder bore (see illustration). Remove "C" clamp. **NOTE** - This will also slide outboard brake pad partially or completely off caliper retaining surfaces.

2) Remove key retaining screw. Using a brass drift, drive out caliper support key and spring. **NOTE** - It is not necessary to disconnect hydraulic line to replace brake pads; therefore, bleeding system is not necessary after reassembly.

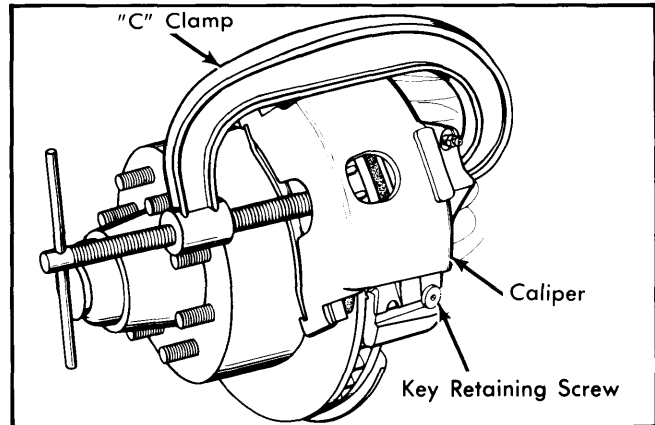

Fig. 1 Using "C" Clamp to Bottom Caliper Piston

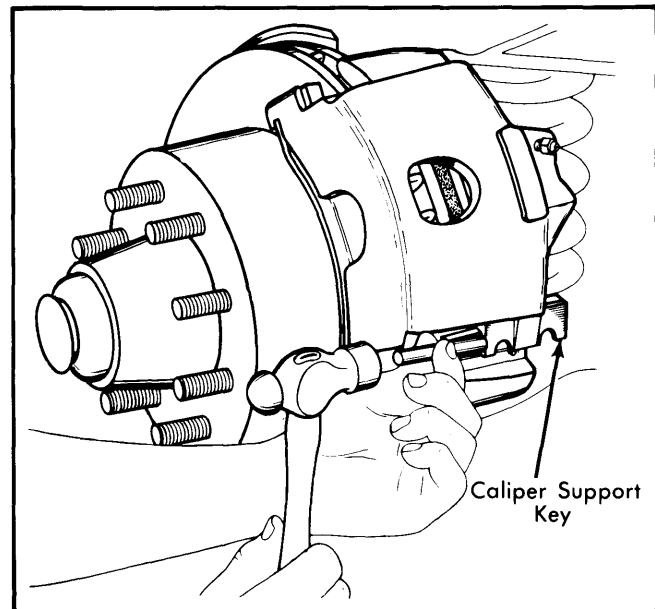

Fig. 2 Driving Caliper Key & Spring from Caliper

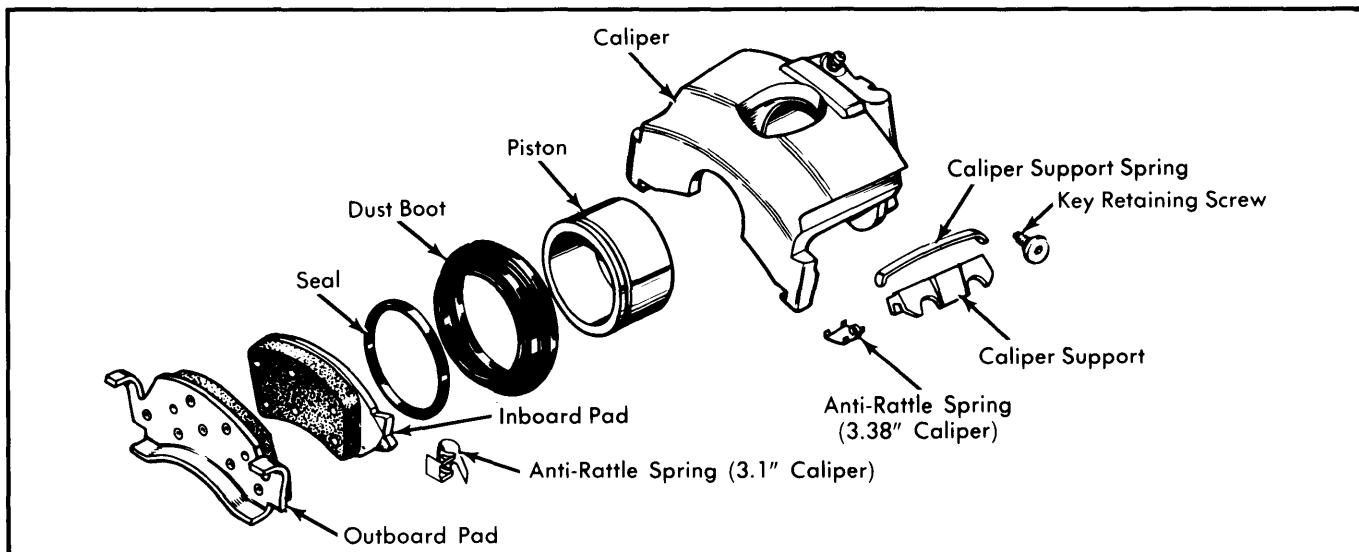

Fig. 3 Exploded View of Sliding Caliper Assembly

Brake Systems

IHC SLIDING CALIPER DISCS (Cont.)

3) Remove caliper from anchor bracket and support caliper assembly on piece of wire. Do not let caliper hang with weight of caliper on brake hose. Remove outboard pad from caliper by tapping it lightly with light hammer and removing with fingers. Remove inboard pad from anchor bracket. Anti-rattle spring will be on pad or anchor bracket; remove it also and discard. Replace all pads if any are less than $\frac{1}{64}$ " above rivet head.

Installation — 1) Attach a new anti-rattle spring to leading end of outboard pad on chassis with 3.1" caliper. Position spring in lower pad abutment of anchor plate on chassis with 3.38" caliper. **NOTE** — Be sure that spring is positioned with loop portion of spring positioned away from rotor.

2) Place lower end of inboard pad and anti-rattle spring in anchor bracket abutment and slide upper end of pad into position. Make sure that spring remains in position and that caliper piston is fully bottomed in cylinder bore. In some instances, it may be necessary to use a "C" clamp to bottom piston.

3) Position outboard pad on caliper and use fingers to press pad tabs into place. If pad cannot be pressed into place on outboard arms of caliper by hand, a "C" clamp may be used. Use caution not to mar braking surface of pad. Position caliper in anchor bracket using caution not to damage dust boot as it slips over inboard shoe.

4) Hold caliper in upper position with upper machined surface of caliper against machined surface of anchor bracket. Position caliper support spring and caliper support key between bottom edge of caliper and anchor bracket. Drive key and spring into position with brass rod and hammer. Install key retaining screw.

5) Check master cylinder fluid level, then press on brake pedal firmly several times to seat pads against rotor.

CAUTION — Do not move vehicle until firm pedal is obtained.

OVERHAUL

BRAKE CALIPER

Disassembly — 1) Disconnect brake hose from caliper inlet port. Cap hose and plug inlet to prevent brake fluid leakage. Remove caliper and pads. If pads are to be reused, avoid get-

ting grease or fluid on them. Clean exterior of caliper with denatured alcohol. Remove plug from inlet port and drain brake fluid from caliper housing.

2) Remove piston from caliper. If necessary, air pressure may be applied through inlet port to force piston from bore. **CAUTION** — Use as little pressure as possible. To avoid injury, keep fingers away from piston face when air pressure is applied. Protect piston from possible damage by directing it into clean cloths. Remove boot from piston and seal from caliper cylinder bore.

Reassembly — 1) Use a wire brush to remove any rust or corrosion from caliper and anchor bracket. Clean caliper housing and piston in clean denatured alcohol. Use clean, dry compressed air to clean out and dry grooves and passages. Make sure that cylinder bore is free of foreign matter and corrosion, especially seal and boot groove.

2) Check cylinder bore, seal groove and boot groove in bore and piston for damage or excessive wear. Replace piston if it is pitted, scored, or worn. Inspect shoe anti-rattle spring, caliper support spring and caliper support key and replace if damaged.

3) Dip new piston seal in clean brake fluid and install in groove of caliper bore. Position seal at one area in groove and gently work around groove with clean fingers until properly seated. Be sure seal is not twisted or rolled.

4) Coat sealing lips on dust boot and piston installer tool (3.1" Caliper, SE-2505; 3.38" Caliper, SE-2504) with clean brake fluid. Assemble new boot on piston installer tool (see illustration). Position tool and boot squarely on cylinder bore, and seat large bead of boot in cylinder bore groove by reaching inside tool and pressing bead into groove on caliper. Make sure bead is fully seated.

5) Apply brake fluid to exterior of piston and insert inside of tool. Locate piston squarely in cylinder bore and apply steady pressure on piston forcing it about half way into cylinder. A wooden stick may be used. Remove tool and seat small bead of boot in piston groove. Continue to press on end of piston until it is bottomed in cylinder bore. Install pads and caliper in vehicle and connect hydraulic hose.

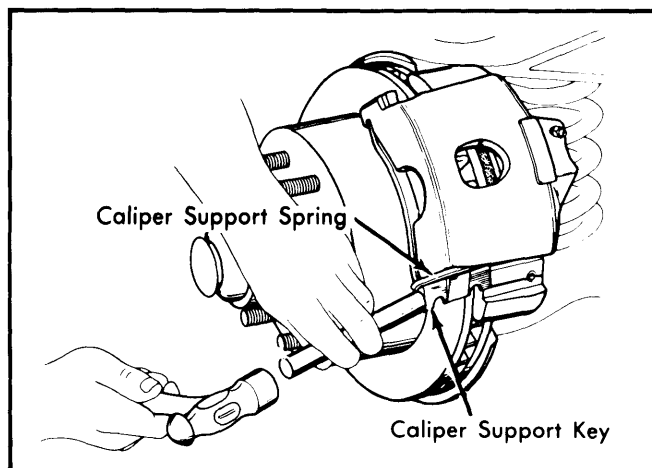

Fig. 4 Installing Caliper Key & Spring

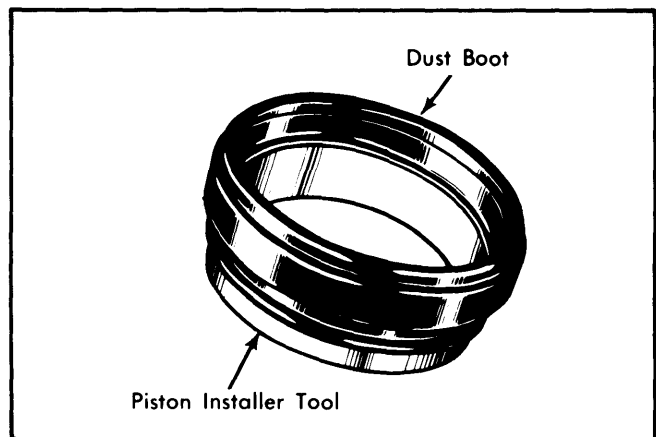

Fig. 5 Piston Installation Tool & Dust Boot Assembled

IHC SLIDING CALIPER DISCS (Cont.)

ROTOR

Runout & Parallelism – Temporarily adjust wheel bearings for zero end play and mount dial indicator on bearing adjusting nut. Indicator stylus should contact rotor one inch from rotor edge. Rotate wheel to check runout (see specifications). Readjust bearings after runout check. Measure rotor thickness at four equal points with a micrometer, one inch in from edge (see specifications). Light scoring or wear on rotor is acceptable. If scoring is deep, runout or thickness variation beyond specifications, and rotor is above minimum allowable thickness, resurface rotor on brake lathe equipped for rotor machining. Always machine both sides of brake rotor simultaneously in order to maintain necessary parallelism. Do not remove more than .030" from each surface of rotor.

TIGHTENING SPECIFICATIONS

Application	Ft. Lbs.
Support Key Retaining Screw.....	12-18
Brake Hose Inlet Bolt.....	24-27
Torque Plate Mounting Nuts (4x4 Vehicles).....	30-33

BRAKE SPECIFICATIONS

Application	3.1" Caliper	3.38" Caliper
Piston Diameter.....	3.1"	3.38"
Brake Pad Lining Size		
Outboard.....	6.40"x1.80"	8.00"x1.80"
Inboard.....	5.16"x1.90"	6.00"x1.80"
Brake Pad Lining Thickness		
Outboard.....	.400"	.430"
Inboard.....	.450"	.530"
Rotor Diameter.....	11.75"	12.75"
Rotor Thickness.....	1.18"	1.18"
Minimum Rotor Thickness.....	1.12"	1.12"
Rotor Runout.....	.004"	.005"