

# Power Steering

## SAGINAW ROTARY VALVE

American Motors  
 General Motors  
 Ford Torino & Elite 351" (Non A/C or Police)  
 Mercury Cougar & Montego 351" (Non A/C or Police)

### DESCRIPTION

Gear is variable ratio recirculating ball type. Steel balls work as a rolling thread between steering gear worm shaft and rack-piston nut. Wormshaft is supported by a thrust preload bearing and two conical thrust races at lower end, and a bearing assembly in adjuster plug at upper end. This design provides continual spring loaded pressure on wormshaft to prevent loss of thrust bearing preload for life of gear. Adjuster plug provides initial preload adjustment and service adjustment when servicing gear. As wormshaft is turned right, rack-piston moves upward in gear; turning wormshaft left moves rack-piston downward in gear. Rack-piston teeth mesh with sector which is forged as part of pitman shaft. Turning wormshaft turns pitman shaft which turns wheels through mechanical linkage.

### LUBRICATION

Check fluid level in pump reservoir every 6,000 miles. Steering gear and fluid must be at normal operating temperature. If necessary, add fluid to bring level to proper mark on dipstick.

### ADJUSTMENT

#### STEERING GEAR

*NOTE* — Due to difficulty in adjusting worm bearing preload and drag induced by hydraulic oil, adjustments should be made with gear removed from vehicle. Two thrust bearing adjustment procedures follow. One for gears with conical thrust races and one for flat thrust races. Some service gears and overhaul kits may have flat races. If uncertain about race type, perform thrust bearing preload for conical thrust races to determine type used.

**Thrust Bearing Preload (Conical Thrust Races) — 1** Drain gear fluid by rotating stub shaft from stop to stop several times. Mount gear in a vise and remove adjuster plug lock nut. Using a spanner wrench, turn adjuster plug clockwise until plug and thrust bearing are firmly bottomed (about 20 ft. lbs.). Scribe an index mark on housing opposite hole in adjuster plug. Measure counterclockwise  $\frac{7}{16}$ - $\frac{1}{4}$ " and mark housing. Rotate adjuster plug counterclockwise until hole in plug is in line with second mark. Tighten lock nut as specified while holding adjuster plug to maintain position.

**2** Turn stub shaft to right stop, then back  $\frac{1}{4}$  turn. Using an INCH lb. torque wrench and a  $\frac{3}{4}$ " deep socket, measure drag torque required to turn stub shaft. Reading should be taken with beam of torque wrench near vertical while turning

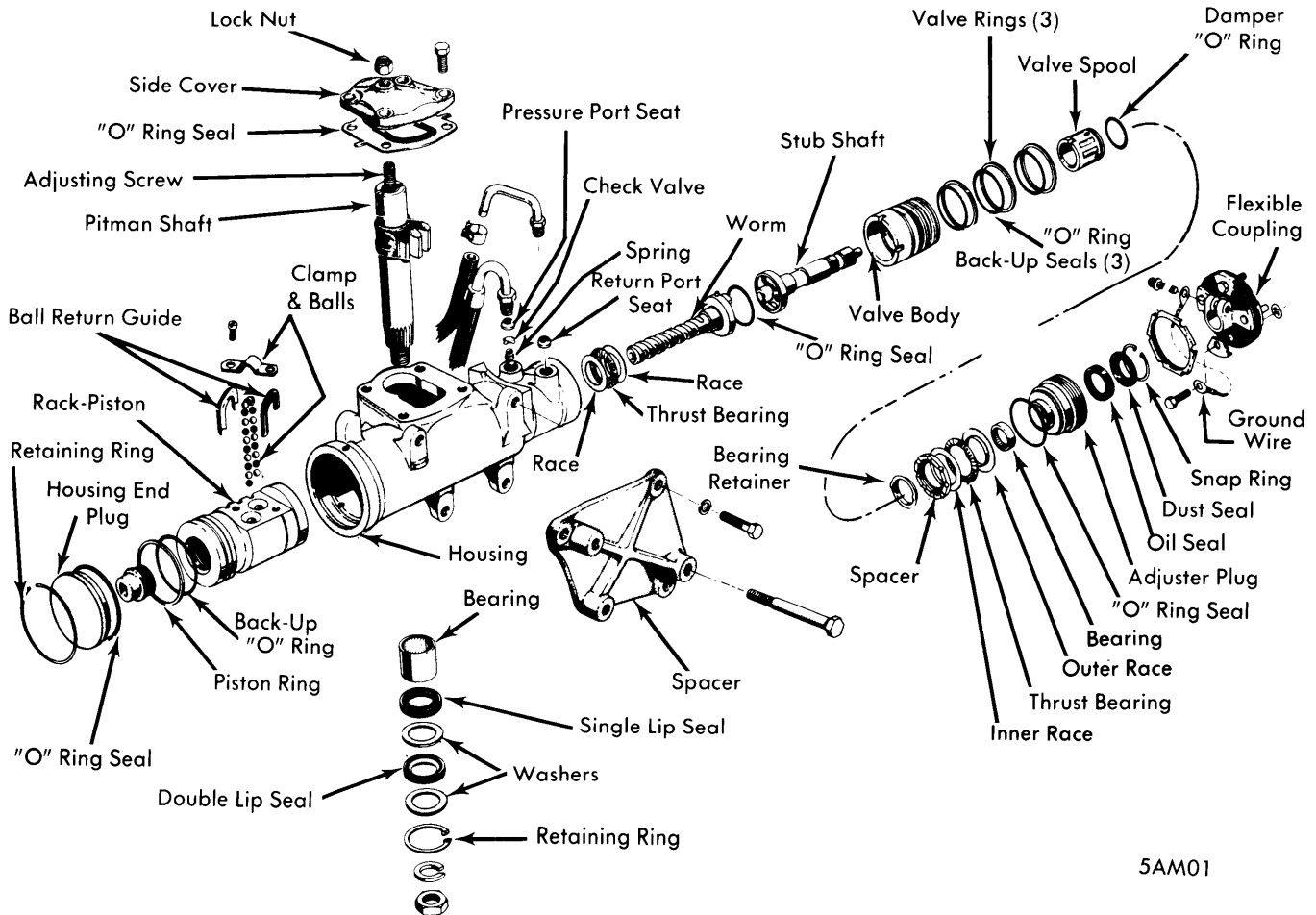

5AM01

SAGINAW ROTARY VALVE POWER STEERING GEAR ASSEMBLY

## SAGINAW ROTARY VALVE (Cont.)

counterclockwise at an even rate. If reading is less than 4 INCH lbs. or more than 10 INCH lbs., use alternate adjustment procedure for flat thrust races. If reading is within 4 to 10 INCH lbs., record reading and continue with pitman shaft overcenter sector adjustment.

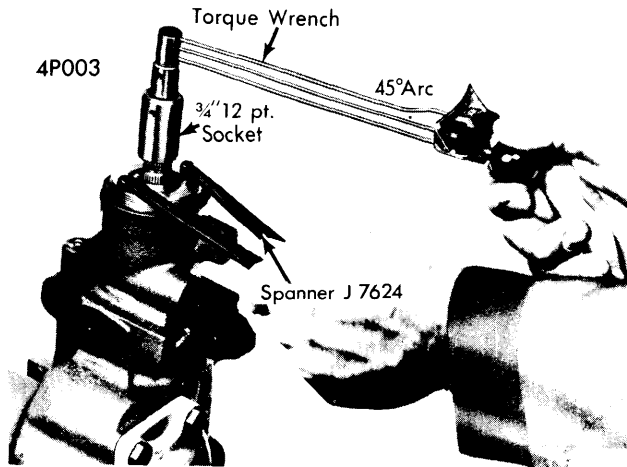

### THRUST BEARING PRELOAD ADJUSTMENT

**Thrust Bearing Preload (Flat Thrust Races)** — Drain gear by rotating stub shaft from stop to stop several times, then mount gear in a vise. Loosen pitman shaft adjusting screw lock nut, then turn adjusting screw 1 1/2 turns counterclockwise. Retighten lock nut. **NOTE** — If screw bottoms when turning it counterclockwise, turn back clockwise 1/2 turn. Loosen adjuster plug lock nut. Using a spanner wrench, loosen adjuster plug one turn counterclockwise. Turn stub shaft to right turn stop, then back 1/4 turn. Using an INCH lb. torque wrench and a 3/4" deep socket, measure drag torque required to turn stub shaft. Turn adjuster plug clockwise until it bottoms, then back off until torque reading is 3-4 INCH lbs. in excess of drag torque noted previously. Tighten adjuster plug lock nut, then recheck preload torque. **CAUTION** — It is not possible to properly adjust thrust bearing preload unless adjuster plug is firmly bottomed and torque set while adjuster plug is being loosened. Never attempt to adjust thrust preload while tightening or advancing adjuster plug into gear assembly.

**Pitman Shaft Overcenter Sector Adjustment** — Rotate stub shaft from stop to stop, then turn back 1/2 total number of turns. Rotate torque wrench approximately 45° each side of center and read highest reading on or near center. Loosen lock nut and turn preload adjusting screw clockwise until correct overcenter torque, in addition to reading just taken is obtained. Correct overcenter torque for a new gear (less than 400 miles) should be 4-8 INCH lbs. additional torque, but not to exceed 18 INCH lbs. total. For a used gear (over 400 miles), overcenter torque should be 4-5 INCH lbs. additional torque, but not to exceed 14 INCH lbs. total. After adjustment, tighten lock nut while holding preload adjusting screw, then recheck adjustment.

## TESTING

### PUMP PRESSURE

Install a suitable pressure gauge between pump and pressure line at pump. With gauge valve open and engine at idle speed, turn wheels against stops to bring fluid to operating temperature. With wheels against stops, pressure should not be less than specified in table. **CAUTION** — Do not hold wheels against stops for more than five seconds. If pressure is below specifications, slowly close valve and check for pressure increase. Pressure will increase if pump is in good condition. If pressure does not increase with valve closed, pump is faulty. **CAUTION** — Do not hold valve closed for more than five seconds. After removing gauge, bleed hydraulic system.

### Pump Pressure Specifications

Model	Minimum Pressure (Psi)
American Motors .....	1000
Buick .....	1000
Cadillac.....	1425
Chevrolet	
Corvette .....	900
Monza & Vega .....	750
All Others .....	1350
Ford Motor Co. (Thompson Slipper Pump).....	1125
Oldsmobile.....	1350
Pontiac.....	1350

## REMOVAL & INSTALLATION

### STEERING GEAR

**American Motors** — Disconnect hose from gear then raise above pump level. Remove flexible coupling nuts, noting difference in size to aid in reassembly. Using a suitable puller, remove pitman arm. Remove steering gear mounting screws and lower steering gear. To install, center steering gear with flat on shaft facing up. Install coupling bolts to shaft, then tighten nuts and bolts. Tighten gear mounting bolts and pitman arm nut. **NOTE** — After tightening pitman arm nut, center punch thread at nut for retention. Connect fluid lines and fill gear with power steering gear fluid. Check gear and lines for leaks.

**Ford Motor Co.** — Disconnect hydraulic lines from steering gear and cap openings. Remove flexible coupling bolts and pitman arm. On models with standard transmission, remove

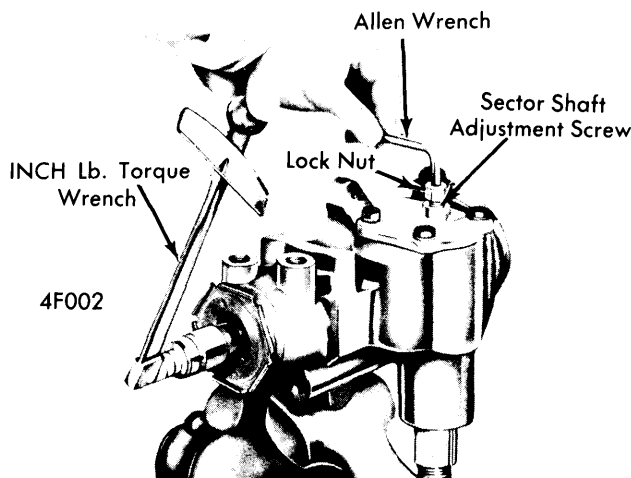

### PITMAN SHAFT END PLAY ADJUSTMENT

## SAGINAW ROTARY VALVE (Cont.)

clutch release lever retracting spring for clearance. Remove steering gear attaching bolts and remove gear from vehicle. To install, reverse removal procedure.

**Buick** — Disconnect hoses from gear, then raise above pump level. Remove steering gear coupling shield, then remove pinch bolt securing lower steering column flexible coupling flange to steering gear stub shaft. Remove pitman arm nut, then remove pitman arm using a suitable puller. Remove steering gear attaching bolts, then remove gear from vehicle. To install, reverse removal procedure. Tighten pitman arm nut and flex coupling pinch bolt as required.

**Cadillac** — Disconnect hoses from gear then position out of way. On Eldorado, remove pitman arm from drag link. On all others, remove pitman arm from gear. Remove flexible coupling shield (if equipped), then remove flexible coupling nuts. Remove steering gear attaching bolts, then remove gear from vehicle. To install, reverse removal procedure. Tighten steering gear mounting bolts, pitman arm nut and flexible coupling nuts as required.

**Chevrolet** — Disconnect hoses at steering gear and cap all openings. Remove flexible coupling nuts, then remove pitman arm from gear. Remove gear to frame bolts, then remove gear from vehicle. To install, reverse removal procedure. Tighten steering gear mounting bolts, pitman shaft nut and flex coupling bolts as required.

**Oldsmobile** — 1) Remove flexible coupling shield (if equipped), then remove coupling flange hub bolt. Disconnect hoses from gear and cap all openings. On Toronado with cooler assembly, disconnect hose at inlet pipe of cooler assembly. Using suitable tools, disconnect pitman arm from intermediate rod (Toronado), or from pitman shaft (all others). Remove gear attaching bolts, then remove gear from vehicle.

2) To install, reverse removal procedure and note following: Lubricate gear mounting pads with sodium soap fine fibre grease. Make certain there is at least .040" clearance between coupling hub and gear upper seal. Tighten gear to frame bolts, pitman shaft nut, pitman arm-to-intermediate rod (Toronado), and coupling flange bolts as required.

**Pontiac** — Disconnect hoses from gear and cap all openings. Disconnect pitman arm from gear using suitable puller. Remove flexible coupling nuts, then remove gear attaching bolts. On Pontiac models, remove brake hose bracket before removing gear attaching bolts. Remove gear from vehicle. To install, reverse removal procedure. Tighten gear mounting bolts, pitman arm and flex coupling bolts as required.

## OVERHAUL

### STEERING GEAR

**NOTE** — If complete assembly is not to be overhauled, remove unit to be serviced and proceed to disassembly and reassembly of that unit.

**Disassembly** — Rotate end plug retainer ring so one end of ring is over hole in housing. Force end of ring from its groove and remove ring. Rotate stub shaft counterclockwise to force end plug from housing. **CAUTION** — Do not rotate more than necessary or balls from rack and worm assembly will fall out. Remove cover and discard "O" ring, then remove end plug. Loosen pitman shaft adjusting screw lock nut and remove side

cover attaching bolts. Rotate side cover until rack and piston and pitman shaft teeth are visible, then turn stub shaft until shaft teeth are centered in housing opening. Tap pitman shaft with soft hammer, then remove shaft and side cover from housing. Remove and discard side cover "O" ring. Insert ball retainer tool (J 7539) into rack-piston bore with pilot of tool seated in end of worm. Turn stub shaft counterclockwise while holding tool tightly against worm. Rack-piston will be forced onto tool. Remove rack-piston and tool from housing. Remove adjuster plug lock nut and using suitable spanner wrench, remove adjuster plug assembly and "O" ring. Grasp stub shaft and pull assembly from housing bore. Separate worm and shaft, and remove stub shaft cap "O" ring. If worm or lower thrust bearing and race remained in gear housing, remove at this time.

**Reassembly** — 1) Lubricate all parts with suitable power steering fluid. Install conical thrust washers in same direction with cupped side toward worm shaft. Install one thrust washer, bearing, and other thrust washer over worm shaft. Install lower shaft cap "O" ring in valve body so it is seated against lower shaft cap. Align narrow notch in valve body with pin in worm, then install valve and shaft assembly in gear housing. **NOTE** — Valve body is properly seated when oil return hole in housing is entirely uncovered.

2) Install new "O" ring in adjuster plug groove. Place suitable seal protector (J-6222) over stub shaft; then install adjuster plug assembly in housing until it seats against valve body. Remove seal protector. Position suitable seal compressor against shoulder of housing. With ball retainer (J-7539) in place in rack piston, push rack piston into housing until tool contacts center of worm. Turn lower shaft clockwise to thread rack piston onto worm shaft, then remove tool.

3) Install new "O" ring in pitman shaft side cover. Turn lower shaft until rack piston teeth are centered in pitman shaft opening, then install shaft and cover so center tooth of pitman shaft engages center groove of rack piston. Install side cover bolts and tighten as required. Install rack piston plug and tighten as required. Install housing end plug "O" ring, fill gear end with power steering fluid, then install end plug and retaining ring. Perform steering gear adjustments before installing gear in vehicle.

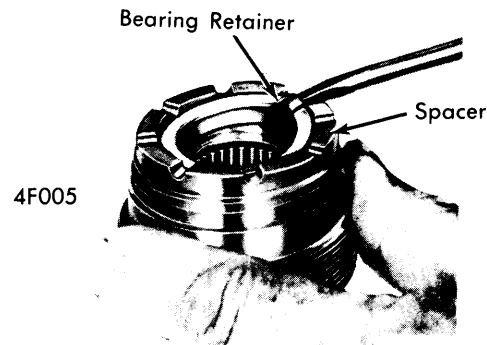

REMOVING UPPER THRUST BEARING RETAINER

### ADJUSTER PLUG

**Disassembly** — Remove thrust bearing retainer being careful not to score needle bearing bore. Remove thrust bearing spacer, bearing and bearing races. Remove adjuster plug "O" ring and stub shaft seal snap ring. Remove dust seal.

## SAGINAW ROTARY VALVE (Cont.)

Remove stub shaft seal. Inspect adjuster plug needle bearings for being broken or pitted. Remove bearing by pressing from thrust bearing end.

**Inspection** — Inspect thrust bearing spacer for cracks and bearing rollers for pitting or scoring. Check bearing races for scoring, cracks or brinelling. If any of these conditions exists, replace both thrust bearing races and spacer.

**Reassembly** — Press needle bearing into adjuster plug with identification marks facing press tool, until bottomed on input shaft seal bore. Install input shaft seal, with spring in seal facing inside of adjuster plug. Install dust seal with lip facing upward, then install retainer ring. Install adjuster plug "O" ring. Assemble thrust bearing, thrust bearing races, and thrust bearing spacer on adjuster plug. Using a brass or wooden dowel, press bearing retainer into needle bearing bore.

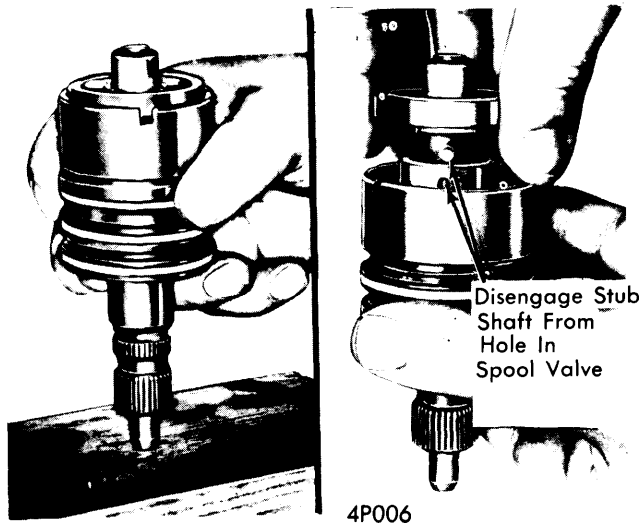

REMOVING STUB SHAFT ASSEMBLY

### ROTARY VALVE

**NOTE** — Complete valve assembly is hydraulically balanced during manufacture. If replacement of any part other than rings or seals is necessary, replace complete valve assembly.

**Disassembly** — Remove and discard "O" ring seal in shaft cap end of valve assembly. While holding assembly (lower shaft down), lightly tap stub shaft against bench until shaft cap is free from valve body. Pull shaft assembly until shaft cap clears valve body approximately 1/4". **CAUTION** — Do not

pull shaft assembly too far or spool valve may become cocked in valve body. Disengage shaft pin from valve spool and remove shaft assembly. Push spool valve out flush end of valve body until dampener "O" ring is exposed, then pull spool from body, while rotating valve. If spool valve becomes cocked, realign valve, then remove. Remove dampener "O" ring from spool valve and discard. Cut plastic oil rings and "O" rings from valve body and discard.

**Inspection** — Check spool valve drive pin for cracks or excessive wear; replace complete valve and shaft assembly as required. **NOTE** — Small flat spots on either side of spool valve drive pin head are normal. Check machined surfaces of stub shaft and spool valve for scratches, nicks or bad wear spots. If nicks cannot be cleaned up with crocus cloth, replace complete valve and shaft assembly. A slight polishing is normal on valve surfaces. If small notch in valve skirt is worn, replace valve assembly. Lubricate spool valve and check fit in valve body with "O" ring removed. If binding occurs, replace valve and shaft assembly.

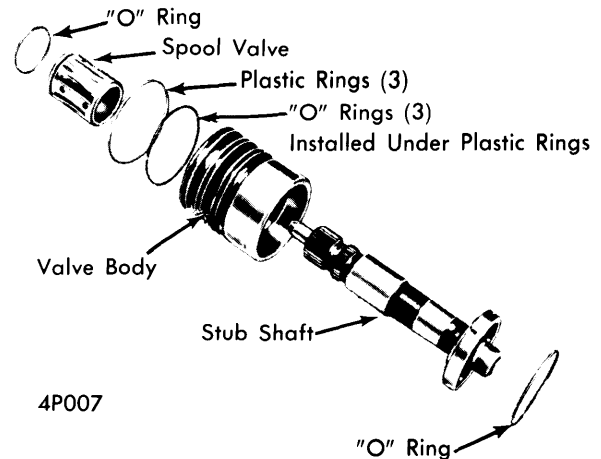

ROTARY VALVE AND STUB SHAFT ASSEMBLY

**Reassembly** — Lubricate back-up "O" ring seals and install on valve body. Avoid twisting seals. Install valve plastic rings over "O" rings. Lubricate new spool valve damper "O" ring with Vaseline and install in spool groove. Lubricate spool valve and slide into valve body until shaft pin hole is visible from other end (spool valve flush with cap end of valve body). Carefully install shaft assembly into spool valve until shaft pin can be inserted into spool valve. Align notch in shaft cap with pin in valve body and press spool valve and shaft assembly

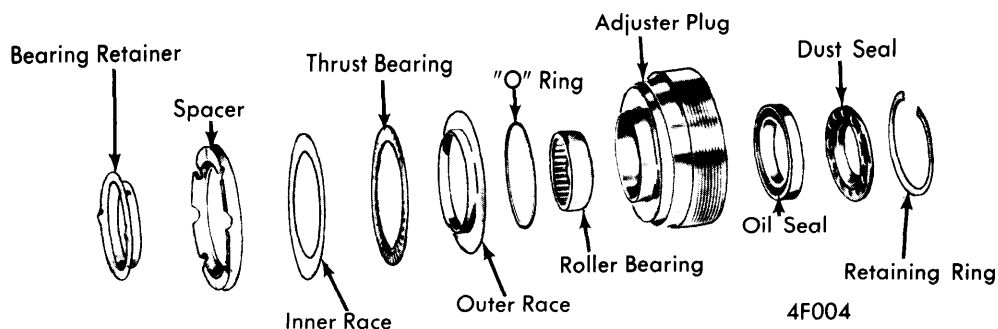

ADJUSTER PLUG ASSEMBLY

## SAGINAW ROTARY VALVE (Cont.)

into valve body. **NOTE** — Check that shaft cap notch is mated with valve body pin before installing valve body into gear assembly. Lubricate new cap-to-worm shaft "O" ring and install in valve body.

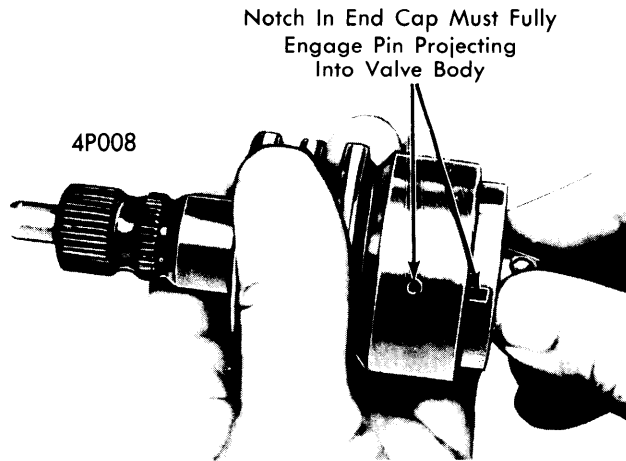

**STUB SHAFT INSTALLATION**

### PITMAN SHAFT & SIDE COVER

**Disassembly** — Remove pitman shaft adjuster screw lock nut and unscrew side cover from adjusting screw. Discard lock nut. **CAUTION** — Do not disassemble pitman shaft.

**Inspection** — Clean and dry all parts. If shaft bearing surface in side cover is badly worn or scored, replace side cover. Make sure sealing and bearing surfaces of pitman shaft are not rough, cracked, nicked, or badly scored. If shaft teeth are damaged, replace shaft. Check pitman shaft lash adjusting screw for ease in turning with no end play. If adjusting screw is loose, replace pitman shaft assembly.

**Reassembly** — Thread side cover onto pitman shaft adjusting screw until it bottoms, then turn in 1/2 turn. Install new adjusting screw lock nut and make over-center adjustment. See *Steering Gear Adjustment*.

### RACK-PISTON & WORM

**Disassembly** — Remove piston ring and back-up "O" ring from rack-piston nut. Remove ball return guide clamp, ball return guide, arbor tool, and all ball bearings from rack-piston.

**Inspection** — Clean and dry all parts. Inspect worm and rack-piston grooves for scoring. Inspect ball bearings for damage. **NOTE** — If either worm or rack-piston are damaged, both must be replaced as a matched set. If any ball bearings are damaged, replace entire set. Check ball guides for pinching at ends. Inspect lower thrust bearing races for cracking, scoring or pitting.

**Reassembly** — 1) Install "O" ring and piston ring on rack-piston, using care not to twist rings. Install worm into rack-piston, until worm is against piston shoulder. Install 17 ball bearings into rack-piston, while slowly rotating worm counterclockwise. **NOTE** — Install light and dark colored balls alternately. Install remaining balls into ball return guide, making sure balls in guide alternate in color with last ball installed in rack-piston. Install guide into rack-piston, install guide clamp, and tighten clamp attaching screws.

2) Clamp rack-piston in a soft-jawed vise, with worm shaft up, and install rotary valve assembly on worm such that it engages worm drive pin. Rotate worm until a clearance of 1/4" exists between rack-piston and thrust bearing face. Install an INCH lb. torque wrench on input shaft, and note torque required to rotate shaft through an arc of 60° in either direction. Torque with worm rotating should be 1-4 INCH lbs. If rotational torque is not correct, install next larger size ball bearings to increase preload, or next smaller size balls to decrease preload. A change of one ball size will change preload about one INCH lb. Balls are furnished in six sizes. Ball size is stamped on rack piston, if no mark is found, ball size seven (standard) is used.

3) Remove valve assembly from worm. Remove rack-piston from vise. Insert suitable arbor tool into plug end of rack-piston until it contacts worm shaft. Apply pressure to tool while rotating worm shaft out of rack-piston. Leave tool in place until piston is installed in housing.

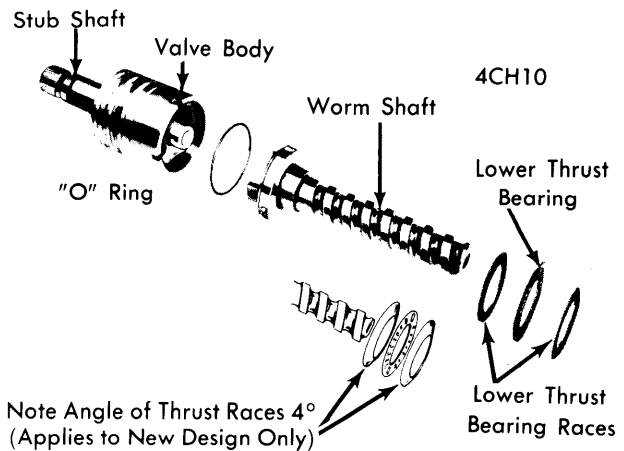

### WORM AND VALVE BODY ASSEMBLY

Rack-Piston Ball Sizes		
Ball Size Number		Size Range
6	.....	.28112-.28122"
7	.....	.28120-.28130"
8	.....	.28128-.28138"
9	.....	.28136-.28146"
10	.....	.28144-.28154"
11	.....	.28152-.28162"

### PITMAN SHAFT SEALS & BEARING REPLACEMENT

**NOTE** — Seals may be replaced with steering gear on or off vehicle.

**Removal** — Remove seal retaining ring, then remove outer steel washer, outer seal, inner steel washer, and inner seal. Remove pitman shaft needle bearing using suitable tool (J6217). **NOTE** — Bearing is flanged and must be removed from pitman arm end of housing.

## SAGINAW ROTARY VALVE (Cont.)

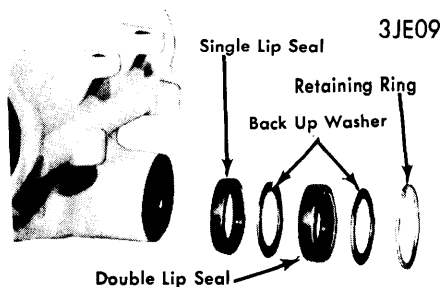

**PITMAN SHAFT SEALS AND WASHERS**

**Installation** — Using suitable tool (J22407), press bearing into housing, until tool bottoms against housing. **CAUTION** — Do not drive bearing further into housing after removing tool, as damage to bearing may result. Using suitable tool (J 6278) and adapter (J 6278-2) install seals with lips of seals facing inside of housing. Install seal retaining ring.

### STEERING GEAR HOSE CONNECTOR SEATS & CHECK VALVE

**CAUTION** — Because of possibility of metal chips entering gear, it is recommended removing gear before performing this procedure.

**Removal** — Turn gear up side down or pack inside of connector seats with Vaseline to prevent chips from entering gear. Tap threads in connector seats using a  $\frac{5}{16}$ -18 tap. Tap only two or three threads to avoid hitting check valve. Thread a bolt with nut and flat washer into tapped hole. Hold bolt and turn nut to pull seat from housing. Wipe housing clean and remove check valve and spring from pressure port.

**Installation** — Install new check valve spring with large end down. Make sure spring is seated in counterbore. Install new

valve over spring with tangs pointing down. Install connector seat using Vaseline to hold seat on valve, and drive seat into place using suitable installer tool (J-6217).

### TIGHTENING SPECIFICATIONS

Application	Ft. Lbs.
Worm Adjuster Lock Nut .....	75-85
Sector Shaft Adjusting Screw	
Lock Nut .....	25-35
Rack Piston Plug .....	75
Side Cover-to-Housing Bolts	
Ford Motor Co. ....	30-45
General Motors	
Buick, Eldorado & Pontiac .....	45
All Others .....	30-35
Gear-to-Frame Bolts	
American Motors .....	60
Ford Motor Co. ....	50-65
General Motors (Exc. Corvette) .....	70-80
Corvette .....	30
Pitman Arm-to-Sector Shaft	
American Motors .....	115
Ford Motor Co. ....	150-225
General Motors "H" Series	
(Exc. Starfire) .....	①140
Oldsmobile Starfire .....	160
All Others .....	185
Flexible Coupling-to-Flange Nuts .....	20-25
Flexible Coupling Pinch Bolt .....	30
Hose Fittings at Gear .....	30-35
Pot Joint Clamp-to-Steering Shaft	
1" Size .....	45-55
$\frac{5}{8}$ " Size .....	35

① — ,Astre, Skyhawk, Starfire, Monza and Vega.