

BENDIX HYDRO-BOOST

Cadillac
Chevrolet
Ford Motor Co.
Oldsmobile

DESCRIPTION

System utilizes power steering pump fluid pressure to operate booster. Assembly contains an open center spool valve which controls pump pressure magnitude during braking, a lever mechanism to control position of the valve, and a boost piston to provide force necessary to operate master cylinder. Unit also has a reserve system which stores sufficient fluid under pressure to provide at least two to three braking applications in case fluid flow from power steering pump is not available. Brakes can also be applied manually if reservoir system is depleted.

OPERATION

RELEASED POSITION (NO BRAKING)

In this position, spool valve return spring holds spool valve open. In open position, spool valve provides unrestricted fluid flow between power steering pump and power steering gear. Fluid pressure is blocked from entering boost pressure chamber by lands on spool valve. As fluid pressure increases with steering demand, it has no effect on boost pressure chamber. Boost pressure chamber is vented through spool valve, to pump return port, and back to power steering pump.

BRAKING POSITION

As brake pedal is depressed, it moves pedal rod and initiates movement of spool valve. This closes fluid return port to pump from boost chamber, and admits fluid into boost chamber from pressure port. Additional valve movement restricts flow between pump and steering gear, causing pump to increase fluid pressure to maintain flow rate to steering gear. As fluid pressure increases in boost chamber, it forces piston forward actuating master cylinder piston, resulting in brake application. If fluid pressure is required for steering while braking, pump pressure will rise and spool valve will shift in an open direction allowing more fluid to flow to steering gear.

RESERVE SYSTEM

1) System consists of a charging valve, accumulator valve, and a compressed gas accumulator. System is open to pressure port of booster unit. Charging valve has an orifice and ball check. Fluid from pump passes through orifice in valve, and if pressure exceeds pressure in accumulator, it unseats ball check valve and enters accumulator. Ball check valve prevents reverse flow when accumulator pressure is greater than pump pressure.

2) Accumulator valve is a poppet type valve held closed by pressure stored in accumulator. An actuator on spool valve sleeve opens accumulator valve when a stop with no pump pressure is made that requires use of reserve pressure. Fluid pressure can also enter accumulator from boost chamber through accumulator valve, when boost chamber pressure exceeds accumulator pressure. A pressure relief valve vents accumulator to pump return port when Pressure in accumulator

exceeds approximately 1600 psi (1400 psi on Ford Motor Co. vehicles).

TESTING

NOTE— Hydro-Boost cannot cause noisy brakes, fading brake pedal, or pulling brakes. If one of these conditions exists, other components of brake system may be the cause.

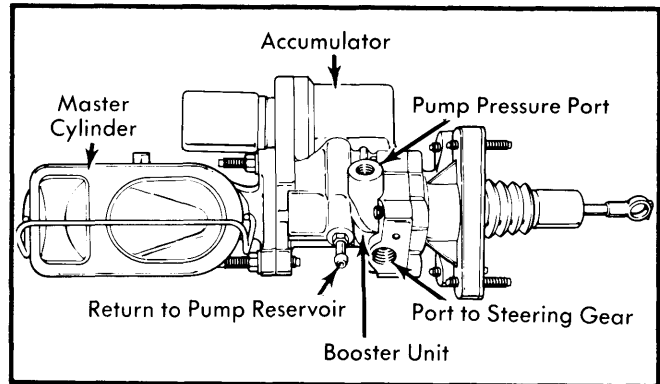

Fig. 1 Cadillac Hydro-Boost Power Brake Unit

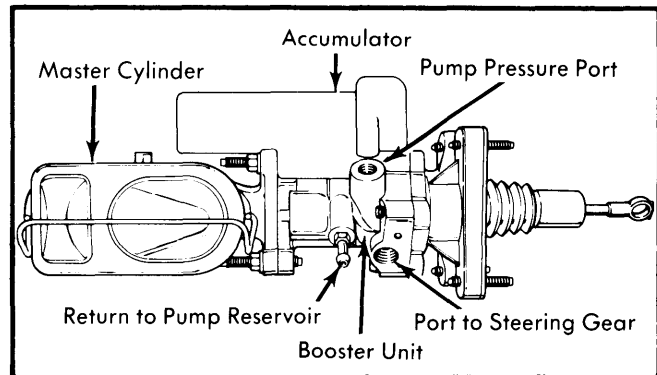

Fig. 2 Ford Motor Co. Hydro-Boost Power Brake Unit Used on Ford, Mercury, Lincoln, & Mark V

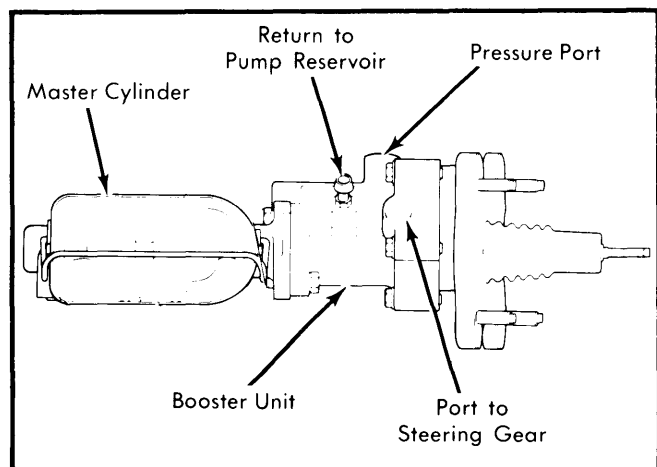

Fig. 3 Ford Motor Co. Hydro-Boost Power Brake Unit Used on Granada, Monarch, & Versailles

Power Brake Units

BENDIX HYDRO-BOOST (Cont.)

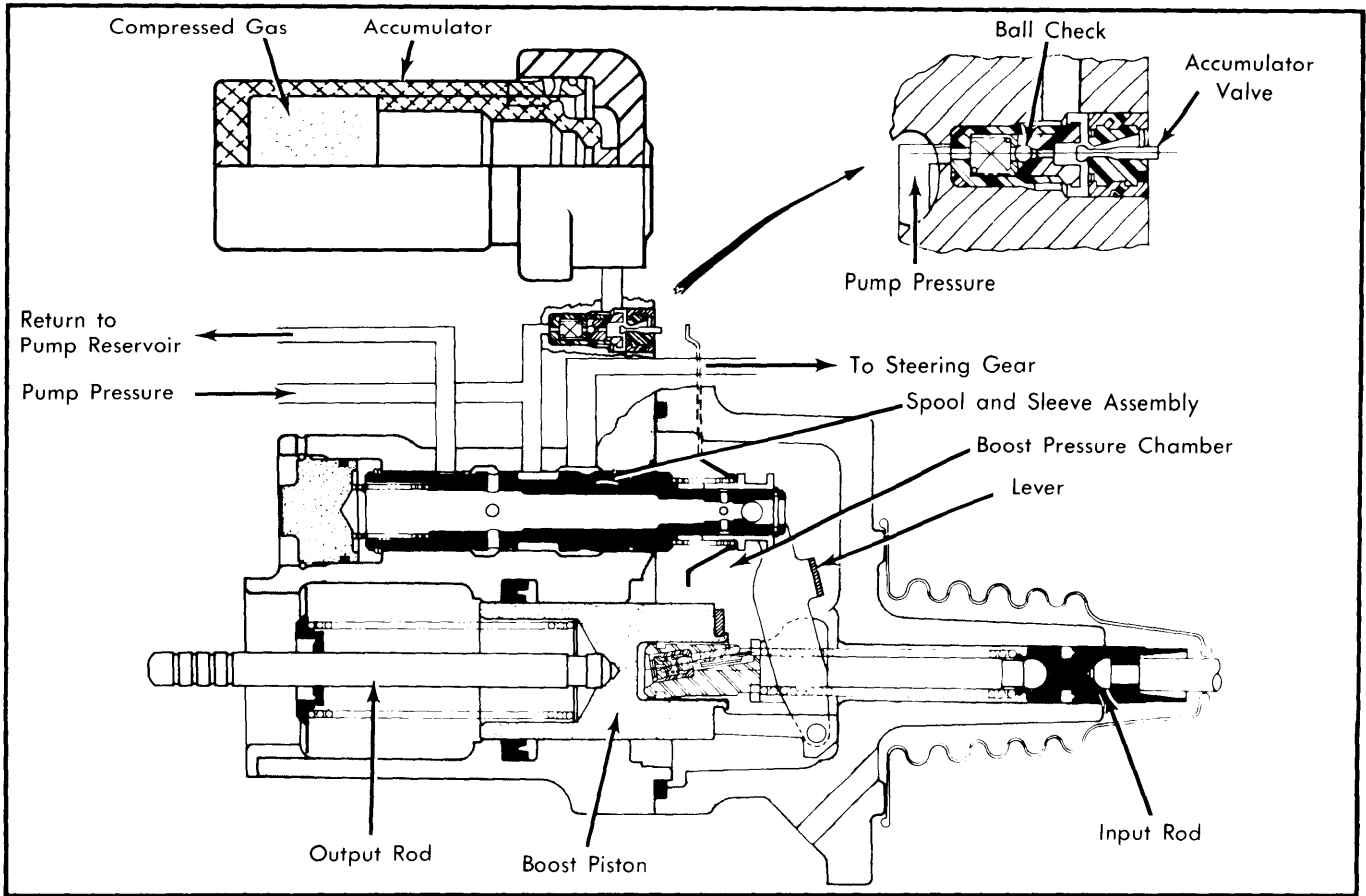

Fig. 4 Sectional View of Cadillac Hydro-Boost Hydraulic Circuits

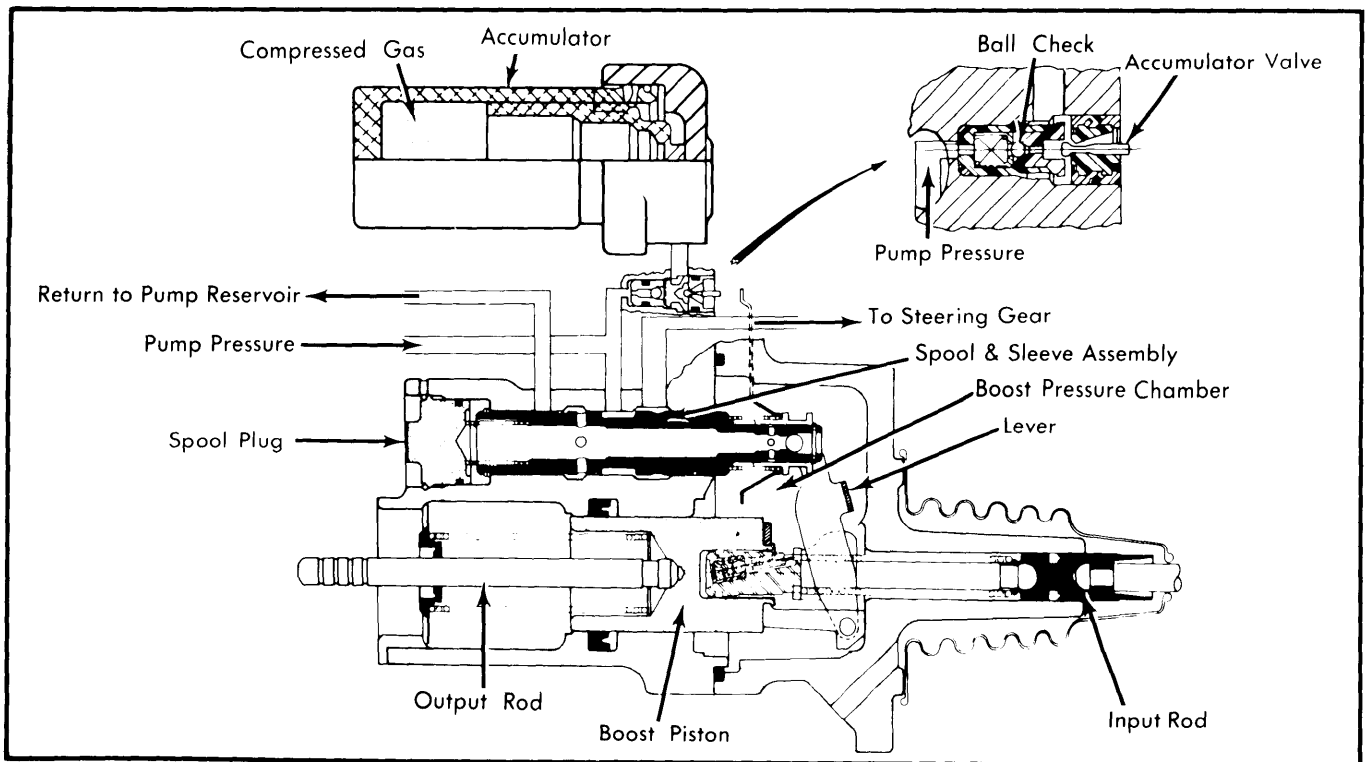

Fig. 5 Sectional View of Ford Motor Co. Hydro-Boost Hydraulic Circuits

BENDIX HYDRO-BOOST (Cont.)

PRELIMINARY CHECKS

Make the following checks, and repair if necessary, before performing any test on the Hydro-Boost system:

- Fluid levels in master cylinder & power steering pump.
- Power steering pump drive belt.
- Power steering hoses for leaks or kinks.
- Air in brake fluid or power steering fluid.
- Engine idle speed.

NOTE — If problem cannot be found in preliminary steps, make following tests. If unit is found to be operating properly, check areas of brake system that might cause condition. See *Hydraulic Brake Trouble Shooting* in this section.

HYDRO-BOOST FUNCTIONAL TEST

- 1) Make all preliminary checks.
- 2) Place transmission in neutral and stop engine.
- 3) Apply brake several times to deplete accumulator reserve. Hold brake depressed with medium pressure (25-35 lbs. on Ford Motor Co., 40 lbs. on all others).
- 4) Start engine. Brake pedal should fall slightly then push back against foot.
- 5) If no action is felt, booster system is not operating properly.

ACCUMULATOR LEAKDOWN TEST

- 1) Start engine and let idle. Turn steering wheel to a lock position and hold for a maximum of five seconds.
- 2) Return steering wheel to center position and shut off engine.
- 3) Depress and release brake pedal, with a medium pedal pressure, until a hard pedal is obtained.
- 4) There should be at least two power-assisted brake applications (three on Cadillac), with medium pedal pressure, before a hard pedal is felt.
- 5) Next start engine and turn steering wheel to a lock position.
- 6) A light hissing should occur as accumulator is recharged.
- 7) Return steering wheel to center position and shut off engine.
- 8) Wait one hour then repeat steps 3) and 4). Results should be the same.

NOTE — If Hydro-Boost is not functioning, insure power steering system is operating normally before replacing Hydro-Boost unit.

REMOVAL & INSTALLATION

HYDRO-BOOST ASSEMBLY

NOTE — Before removing unit, discharge accumulator by making several brake applications until a hard pedal is obtained.

Removal — 1) From inside vehicle and under instrument panel, proceed as follows:

NOTE — On General Motors vehicles there is no stop light switch. Pedal pin is removed after booster unit is removed from firewall.

- Disconnect stop light switch wires to connector.
- Remove hairpin retainer.
- Slide stop light switch off brake pedal pin far enough for switch outer hole to clear pin.
- Remove switch from pin.
- Slide push rod, nylon bushing and washers off brake pedal pin.

2) Working from under hood of vehicle, proceed as follows:

- Remove two nuts attaching master cylinder to booster.
- Move master cylinder to one side without disconnecting brake fluid lines.
- Disconnect pressure, steering gear and return lines from booster unit.
- Plug all lines and ports.
- Remove nuts securing booster to firewall.
- Remove booster unit by sliding push rod link out from engine side of dash panel.

Installation — 1) From under hood of vehicle, perform following steps:

- Mount booster to dash panel by sliding push rod through hole in dash panel.
- Install and tighten attaching nuts.
- Install master cylinder on booster unit, tighten nuts.
- Remove plugs and attach fluid lines to booster unit.

2) From inside of vehicle, perform following steps:

- Install inner nylon washer, booster unit push rod and bushing on brake pedal pin.
- Position switch so that it straddles push rod with slot on pin and outer hole just clearing pin.
- Slide switch onto pin and install washer and hairpin retainer.
- Connect stop light switch wires.

3) Remove coil wire so engine will not start.

4) Fill power steering reservoir.

5) Engage starter and apply brakes in a pumping action, but do not turn steering wheel.

6) Check power steering fluid level and top off if necessary.

7) Install coil wire, start engine and cycle steering wheel.

8) Apply brake with pumping action and check for fluid leaks.

NOTE — If a whine type noise develops following installation of power unit, fluid aeration may be suspected. Air must be removed from system using a suitable power steering pump air evacuator assembly.

Power Brake Units

BENDIX HYDRO-BOOST (Cont.)

OVERHAUL

NOTE — Ford Motor Co. does not recommend overhaul of this unit. If a problem is determined to be in booster unit, complete assembly must be replaced. Do not disassemble booster unit.

CAUTION — Power steering fluid and hydraulic brake fluid CANNOT be mixed. Do not allow power steering fluid to contact brake seals or hydraulic brake fluid to contact power steering seals as seal damage will result.

BRAKE BOOSTER

Disassembly — 1) To facilitate disassembly, mount booster in a holding fixture, with push rod facing downward. Clamp fixture in a vise. See Fig. 7.

2) Pump pedal rod until accumulator pressure is depleted.

3) Cut strap attaching accumulator cap to drip pan.

4) Using special socket (Cadillac No. J-25085) loosen Torx-head bolts attaching front housing to rear cover.

NOTE — Front housing is that part of booster assembly which includes accumulator. Rear cover is that part from which pedal rod extends.

5) With Torx bolts removed, proceed as follows:

- Carefully remove front housing, leaving spool valve and power piston attached to rear cover.
- Remove output rod and piston return spring from power piston assembly.
- Remove spool valve spring from spool valve.
- Remove output rod retainer from front housing.
- Remove spool valve by rotating it out of lever arm.
- Remove and discard seal from rear cover.

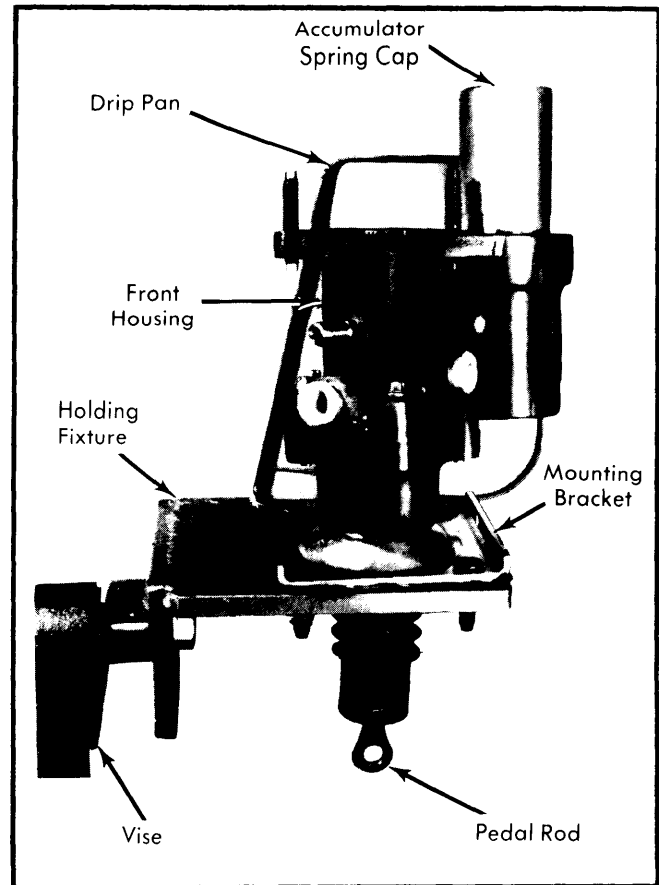

Fig. 7 Mounting Booster on Holding Fixture & Clamping Fixture in a Vise for Booster Disassembly (Cadillac Shown)

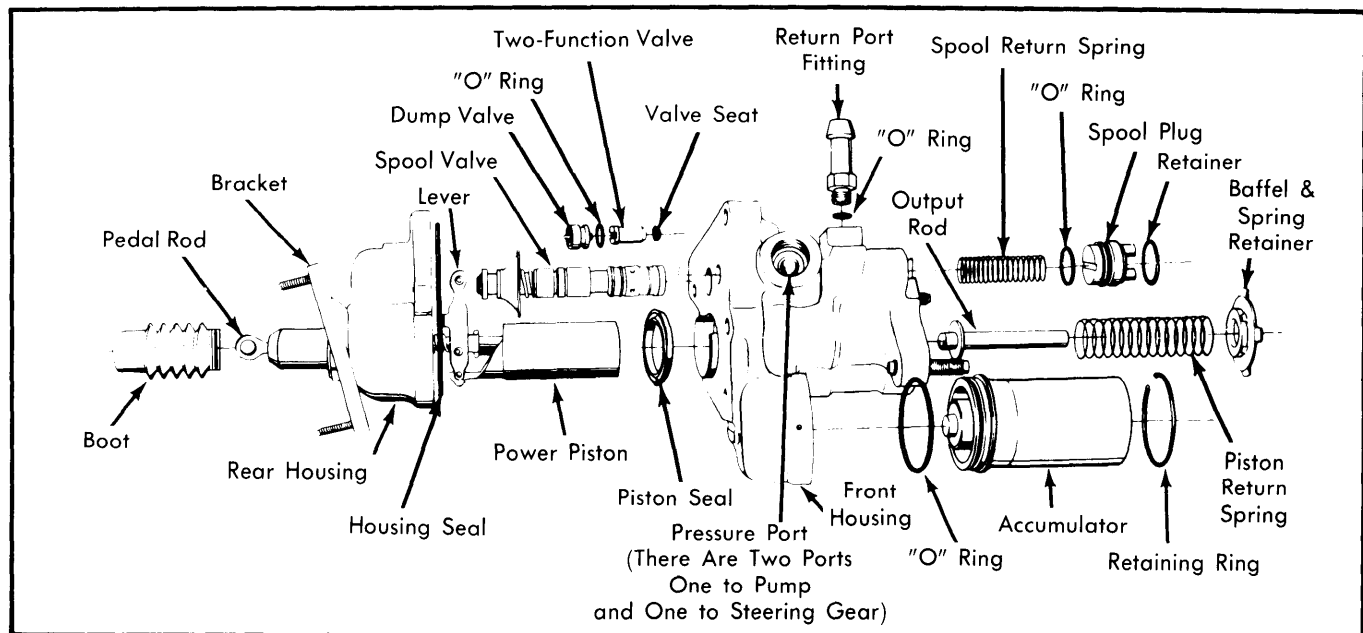

Fig. 6 Exploded View of Typical Hydro-Boost Power Brake System (Chevrolet Unit Shown)

BENDIX HYDRO-BOOST (Cont.)

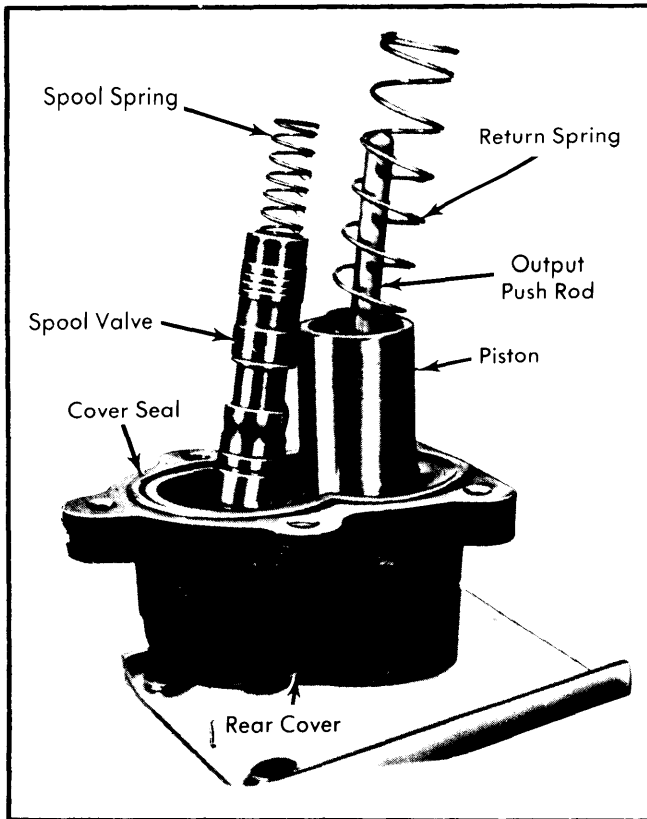

Fig. 8 Booster Rear Cover Assembly Showing Spool Valve & Power Piston (Cadillac Shown)

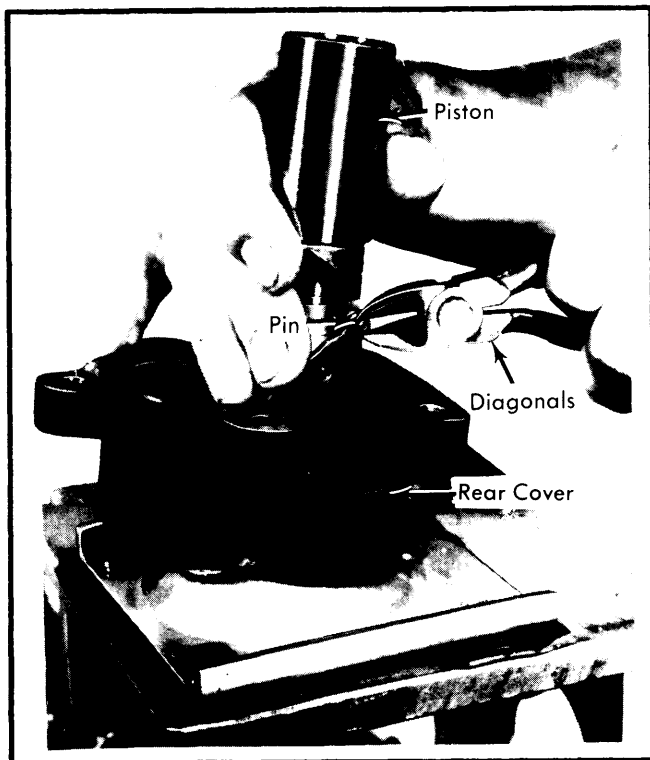

Fig. 9 Using Diagonal Cutters to Remove Booster Power Pin (Cadillac Shown)

6) Inspect spool valve and power piston for wear or scratches. Replace if necessary.

7) Remove power piston by cutting end of connecting pin. Push out pin with a small punch and remove piston.

8) Clean all parts in clean power steering fluid.

Assembly – 1) Position piston bracket into yoke of lever and install new pin through hole.

2) Use a punch to mushroom end of pin. Make sure lever is free to move with no binding.

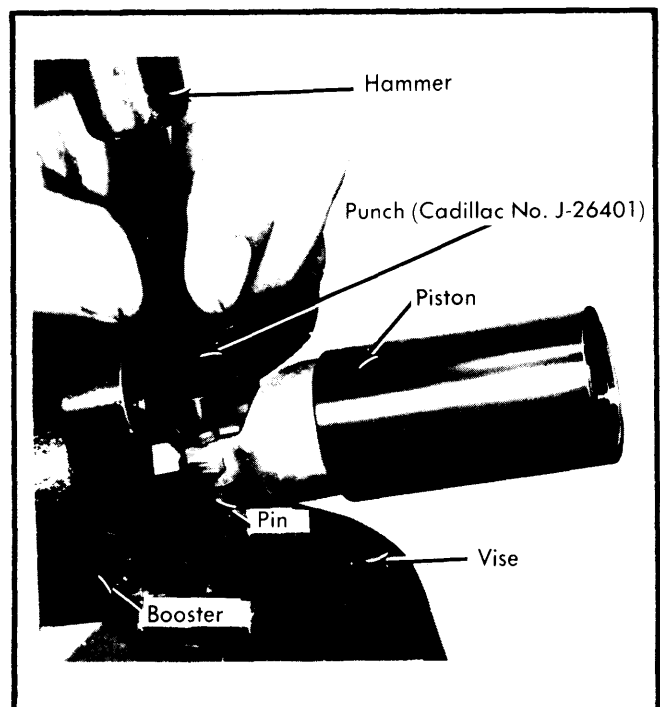

Fig. 10 Staking Booster Piston Pin (Cadillac Shown)

3) Install new seal in rear cover groove and new power piston seal in front housing.

4) Pull up on power piston and extend lever to accept sleeve on spool valve.

5) While holding lever extended, bring front housing with spool valve directly over rear cover and slide lever pins into slot in sleeve.

6) Install rear cover to front cover as follows:

- Center power piston in bore.
- Lower front housing down onto rear housing.
- Before housings contact, install seal protector (Cadillac No. J-25053) through piston bore, until seated on piston.
- Push housings together and remove seal protector.
- Tighten Torx bolts to 20 ft. lbs.

BENDIX HYDRO-BOOST (Cont.)

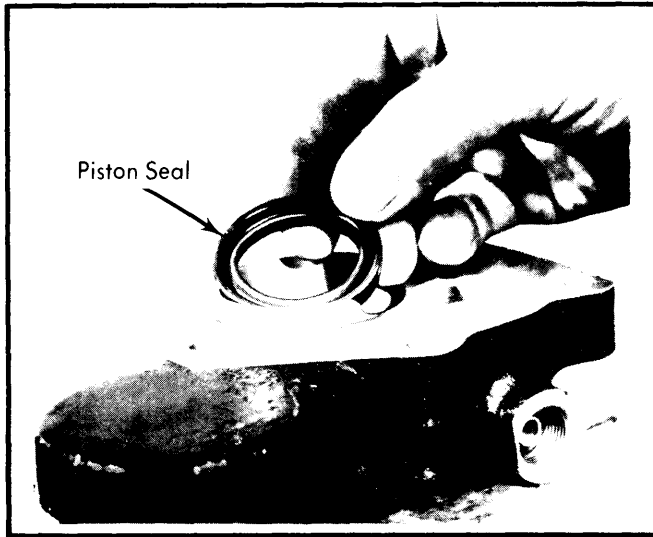

Fig. 11 Installing New Power Piston Seal into Rear Housing (Cadillac Shown)

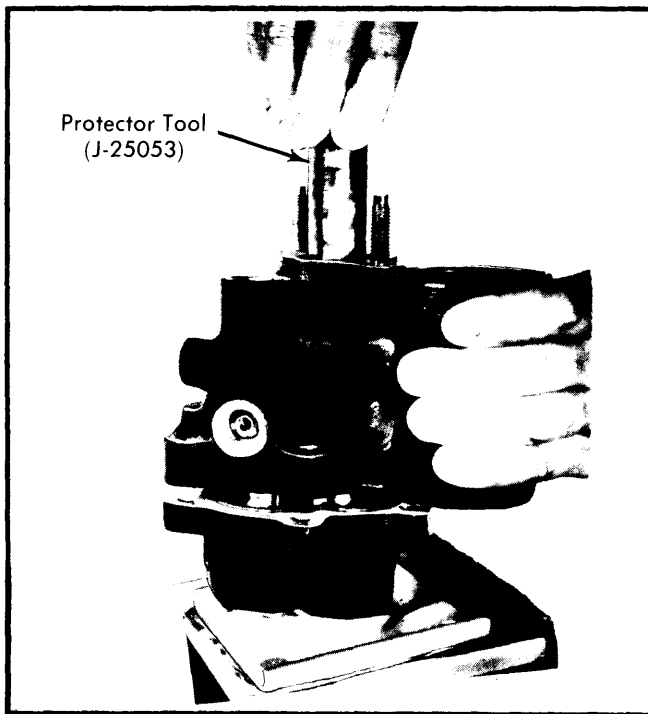

Fig. 12 Installing Seal Protector Tool Through Front Housing (Cadillac Shown)

7) Install output rod, spring and a new spring retainer.

8) Using a $\frac{7}{8}$ " deep socket, tap spring retainer into housing and install new support strap to drip pan.

ACCUMULATOR RESERVOIR

Disassembly - 1) Place booster unit on holding fixture and place in a vise with pedal rod facing down.

2) Pump pedal rod several times until accumulator pressure is depleted.

3) Place a protective cap (Cadillac No. J-26889) over accumulator and install a large clamp to accumulator and housing. See Fig. 13. Then proceed as follows:

- Depress accumulator can approximately .10" with vise.

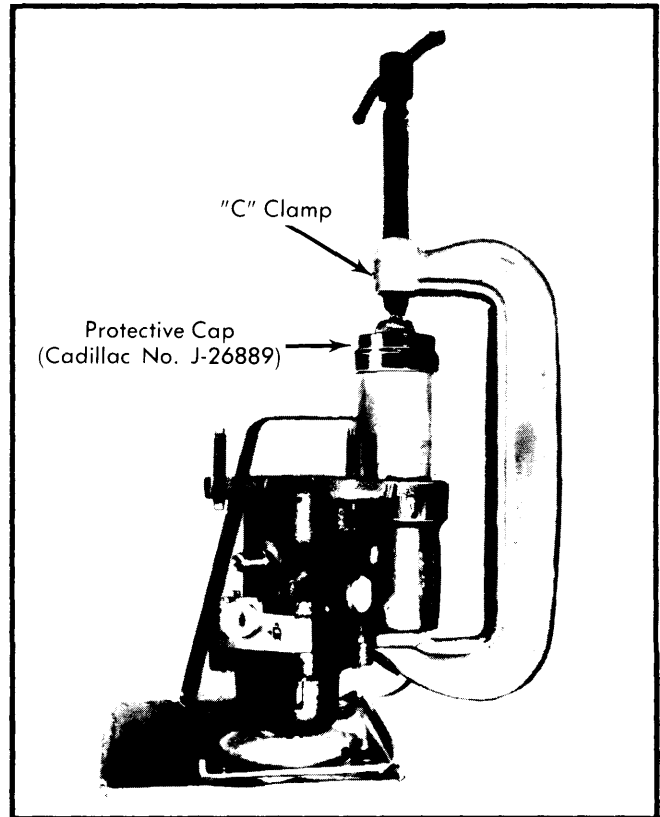

Fig. 13 Installation of Clamp and Protective Cap for Removal of Accumulator Can (Cadillac Shown)

NOTE - If accumulator can doesn't compress easily it is still charged and indicates internal valve problems. If this is the case, complete booster must be disassembled.

- Unseat retainer ring by inserting punch into hole in housing.
- Remove ring with small screwdriver.
- Slowly loosen clamp until tension on can is removed.
- Remove clamp, retaining cap, and accumulator can.

Assembly - 1) Use clean power steering fluid as lubricant on accumulator can seal. Mount booster on holding fixture and in a vise. Proceed as follows:

- Place accumulator can in housing.
- Slide retaining ring over can.
- Install protective cap over can and place clamp on cap and housing.
- Compress can with clamp, make sure can is straight.
- Push retaining ring down around can until it snaps into place.
- With ring snapped into place, slowly remove clamp.