

BENDIX/DELCO-MORAINÉ DUAL PISTON MASTER CYLINDER

American Motors
Chrysler Corp.
Ford Motor Co.
General Motors

DESCRIPTION

All master cylinders are single cylinder with front and rear pistons. Master cylinders can have divided or common reservoirs that are integral with the piston cylinder. Aluminum master cylinders have reservoirs that are removable from piston cylinders. Front piston is operated by rear piston. In a divided reservoir, larger reservoir feeds disc brakes. A residual pressure valve is located in the master cylinder under outlet seat for drum brakes. This keeps small amount of pressure in drum brake circuit. Disc brake outlet does not have residual pressure valve and must not have any residual pressure or they will lock up.

NOTE — Chrysler models do not use a residual valve for rear drum brakes.

On some master cylinders a stop screw is screwed in from outside of cylinder. This screw limits the return stroke of front piston.

REMOVAL & INSTALLATION

MASTER CYLINDER

Removal — 1) On power brake systems, disconnect switch wire (if equipped) and all hydraulic lines. Remove cylinder mounting nuts and remove cylinder.

2) On manual brake systems, disconnect negative battery cable, remove stop light switch and spring retainer (if required), disconnect switch wire (if equipped) and all hydraulic lines. Remove cylinder mounting nuts, slide cylinder forward to remove from pushrod and remove cylinder.

Installation — 1) Master cylinder must be bled before bleeding entire system. Master cylinder bleeding may be done on vehicle. Preferred method is to bleed master cylinder on bench. If master cylinder has a bleed screw, bench method should still be used. When master cylinder is installed on car, use bleed screw as a final check for trapped air.

2) Place master cylinder level in a vise. Attach bleeding tubes to cylinder. Fill reservoirs with fluid so that ends of tubes are covered (see Fig. 1). Tubes attached to disc brake outlets must have residual pressure valves installed over ends. This will keep tubes from siphoning.

3) Stroke piston in bore with a wooden stick or dowel until bubbles no longer appear at ends of tubes. Remove tubes and plug the master cylinder disc brake outlets to keep fluid from draining.

4) Install master cylinder on car, reversing removal procedure. Bleed master cylinder bleed screw first, if used, and then bleed remainder of system. See "Hydraulic Brake Bleeding" in this section.

5) Check master cylinder compensating ports by pumping brake pedal several times, ending with pedal held down. Remove master cylinder cover and slowly release pedal. Fluid should squirt up in each reservoir from the compensating ports.

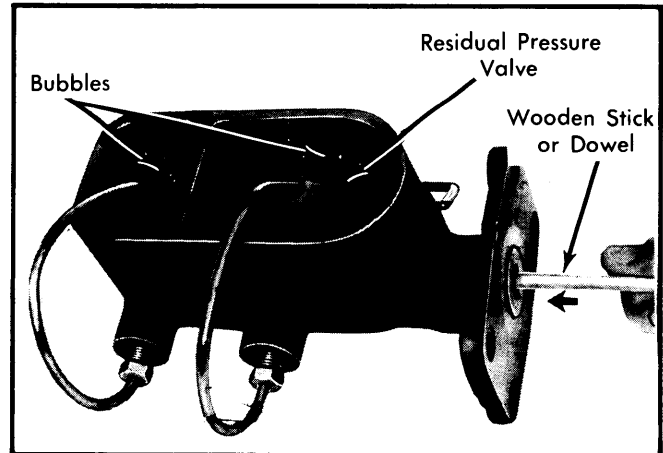

Fig. 1 Bleeding Master Cylinder With Bleeding Tubes Installed

6) If fluid does not squirt in each reservoir, port is plugged or pushrod is too long. Check for plugged port. If port is not plugged, adjust manual brake pushrod at clevis under dash. On power brakes, see *Push Rod Adjustment under POWER BRAKE UNITS* in this section.

CAUTION — DO NOT use wire to check ports. Wire may make a burr on port or damage cup.

7) Pushrod should have slight amount of play when in relaxed position, so that both master cylinder pistons will return to stops when brakes are off.

OVERHAUL

MASTER CYLINDER

Disassembly — 1) Drain all brake fluid from master cylinder and clean outside of master cylinder before disassembly. Remove reservoir cover and gasket. On aluminum master cylinders (with removable reservoirs) place a pry bar between master cylinder body and reservoir. Pry up until reservoir can be removed.

2) On all master cylinders, place in a vise. Depress piston and remove stop screw if so equipped. Remove lock ring from groove in end of bore or retainer and screw. Remove rear (primary) piston assembly.

CAUTION — Do not disassemble rear piston assembly or change adjustment of screw.

3) Remove front (secondary) piston with air pressure. If air pressure does not work, use wire hook to pull piston out end of cylinder. Remove front piston spring if it did not come out with piston. Remove splash seal and retainer outside rear of cylinder, if they are used.

NOTE — Ford does not recommend tube seat removal, and Chrysler and American Motors recommend doing so only when tube seats are bad.

4) Remove tube seats to gain access to check valves. Use self-tapping removal kit if supplied in repair kit. If removal kit not available, use one of these methods. Thread a short screw into seat. Pry screw and seat out with a screwdriver. Another

BENDIX/DELCO-MORAINE DUAL PISTON MASTER CYLINDER (Cont.)

method is to drill a $\frac{13}{64}$ " hole through each seat. Then tap hole with a $\frac{1}{4}$ -20 tap. Screw a tubing nut into outlet. Then insert a $\frac{1}{4}$ -20 machine screw (with washer) through nut and into tube seat. Hold screw from turning. Unscrew the tubing nut to remove seat. Remove check valve and spring from drum brake outlet.

Inspection — Inspect cylinder bore for scoring or corrosion. Staining which has not pitted or roughened the surface can be removed with crocus cloth. Move cloth in circular manner. Never polish cylinder with lengthwise strokes. If cylinder is scored, corroded or pitted, vehicle manufacturers (except Ford Motor Company) recommend replacing cylinder. Ford Motor Company permits honing if bore diameter increase is not over .003".

Reassembly — 1) Put check valve spring in drum brake outlet. **CAUTION** — Check valve in disc brake outlet will cause disc brakes to lock up. Put check valve on top of spring and insert tube seat in outlet against valve. Use a spare tube nut, and screw nut into outlet to bottom tube seat. Remove nut and inspect for burrs or shavings caused by installing seat.

NOTE — Before assembly, dip all component parts in clean brake fluid. Assembling seals dry can damage them.

CAUTION — On aluminum master cylinders, DO NOT polish cylinder bore with anything abrasive.

2) Install new secondary cups on rear of front (secondary) piston. Place cup lips facing away from each other. Some front pistons use a cup in rear grooves and an "O" ring in second groove from rear. Place cup so lip faces forward and back of cup is against protector washer.

NOTE — Protector washer may be permanently attached to cup.

3) If it is necessary to disassemble rear (primary) piston for replacement of parts see "Primary Piston Assembly" illustration.

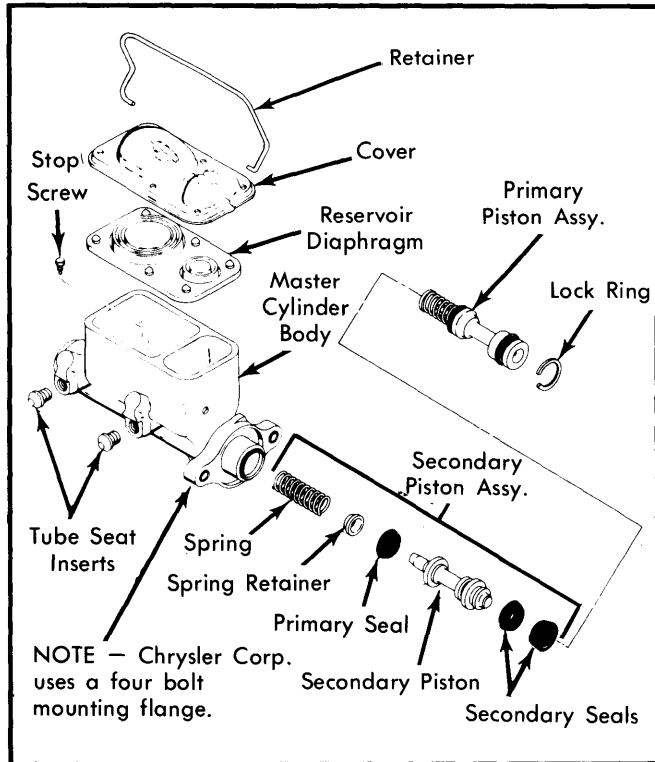

Fig. 2 Typical Delco-Moraine Master Cylinder (General Motors Shown, Others Similar)

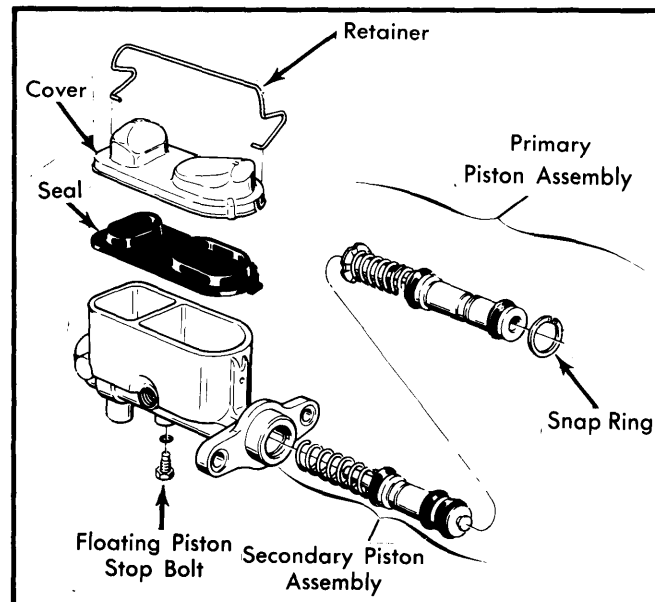

Fig. 3 Typical Bendix Master Cylinder (Ford Motor Co. Shown)

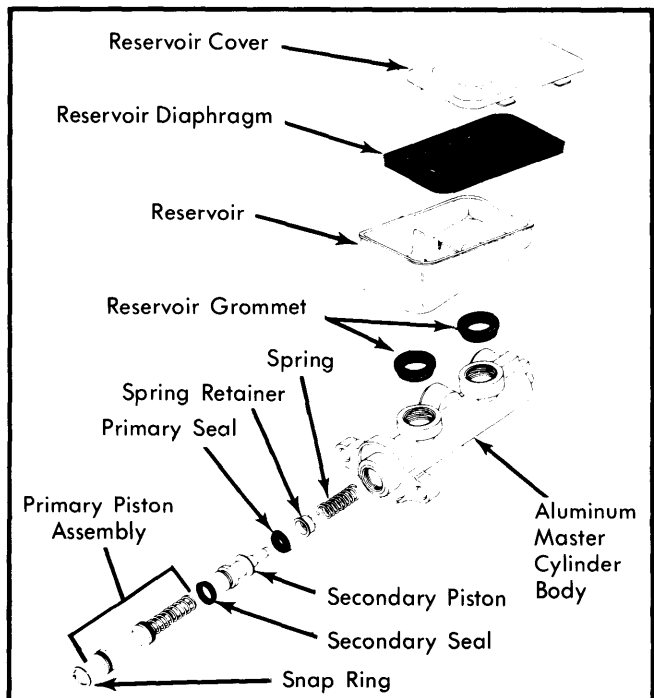

Fig. 4 General Motors Aluminum Body Master Cylinder (Exc. Citation, Omega, Phoenix & Skylark)

Brake Systems

BENDIX/DELCO-MORAINÉ DUAL PISTON MASTER CYLINDER (Cont.)

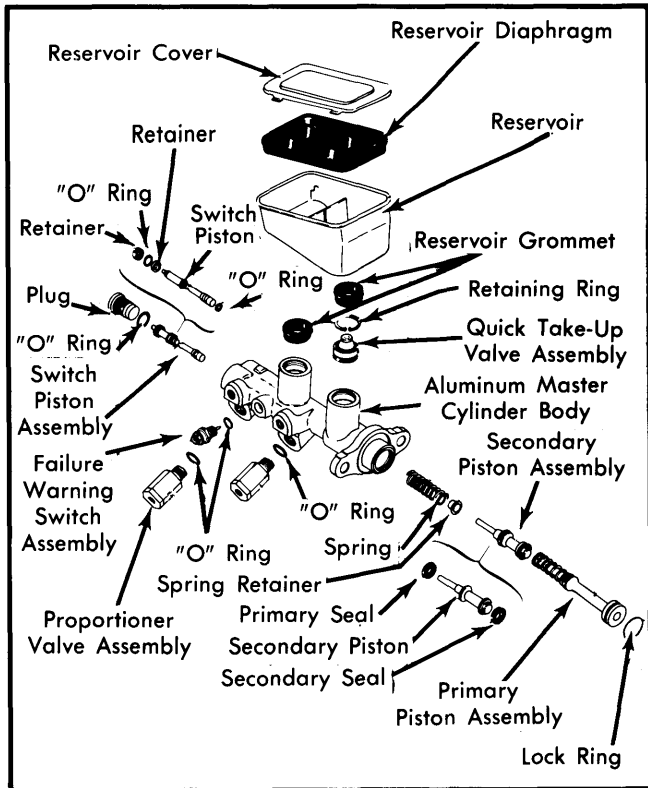

Fig. 5 General Motors Aluminum Body Master Cylinder
(Citation, Omega, Phoenix & Skylark)

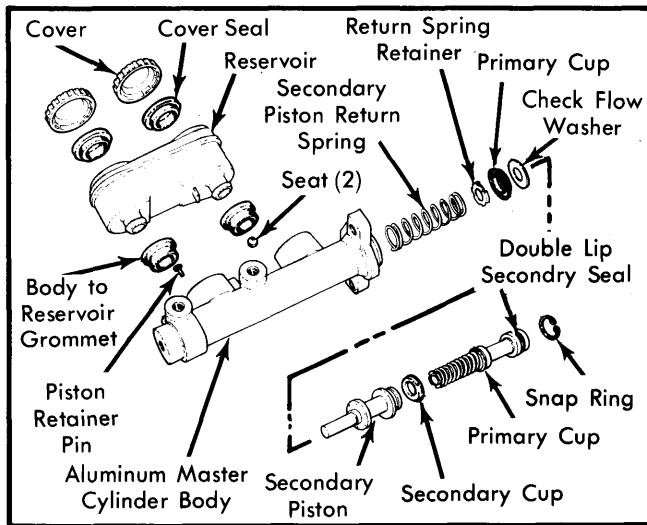

Fig. 6 Chrysler Corp. Aluminum Body Master Cylinder

4) Coat bore of cylinder and all cups with brake fluid. Place spring retainer on end of front spring. Place spring on end of front piston so that retainer is seated inside cup. Hold open end of master cylinder down. Push front spring and piston up into bore until spring seats against end of cylinder.

5) Hold master cylinder with open end up. Insert rear piston assembly with spring end going in first. Install lock ring in groove, or screw and retainer if used. Push rear piston into bore. Install stop screw and "O" ring if used.

NOTE — Stop screw is a special screw. DO NOT use any other type as a substitute.

CAUTION — Cadillac models DO NOT use a stop screw even though a drilled and tapped hole is provided. If stop screw is installed, damage to master cylinder piston or seal will result.

6) Install housing-to-reservoir grommets. Install reservoirs to housing, seating against grommets with a rocking motion. Install master cylinder cover and gasket. Place beaded side of gasket against master cylinder.

7) On manual brake systems, assemble pushrod through retainer if used. Push retainer over end of master cylinder. Install a new boot over pushrod and press boot down over pushrod retainer.

TIGHTENING SPECIFICATIONS

Application	Ft. Lbs.
American Motors	
Master Cylinder-to-Firewall	30
Master Cylinder-to-Power Unit	30
Brake Line-to-Master Cylinder	15
Chrysler Corp.	
Master Cylinder-to-Firewall	17
Master Cylinder-to-Power Unit	17
Brake Line-to-Master Cylinder	15
Ford Motor Co.	
Master Cylinder-to-Firewall	13-25
Master Cylinder-to-Power Unit	13-25
Brake Line-to-Master Cylinder	10-18
General Motors	
Master Cylinder-to-Firewall ^{①②}	25
Master Cylinder-to-Power Unit ^{①②}	25
Brake Line-to-Master Cylinder	13
Pro. Valve-to-Master Cylinder	25

① — Torque to 13 ft. lbs. on Chevette.

② — Torque to 20 ft. lbs. on Cadillac.