

CHRYSLER CORP.

DESCRIPTION

Power seats adjust in six different directions. Seat tilt is controlled by front and rear levers on control switch. Center lever on seat switch controls vertical and horizontal movement. Seat is powered by a three armature reversible motor coupled through cables to rack and pinion assemblies located in seat tracks. The electrical circuit is protected by a 30 Amp. circuit breaker located on fuse block on inside cowl panel to left of steering column.

ELECTRICAL TESTS

If power seat malfunctions, a quick check may be made to isolate failure as either electrical or mechanical. With all harnesses connected and dome light on, operate master switch for direction of seat failure. If dome light dims, the seat motor is probably satisfactory, and mechanical jamming is indicated. If dome light does not dim, proceed with electrical tests.

CIRCUIT BREAKER

With test lamp, check for voltage at power feed terminal. If lamp lights, feed wire is okay. Connect test lamp to circuit breaker output terminal, if lamp lights, circuit breaker is okay.

WIRING HARNESS, CIRCUIT BREAKER-TO-SWITCH

Disconnect wire harness connector under seat. Connect a test lamp between RED and BLK wire in female connector. If test lamp lights, harness is correct (See Fig. 1).

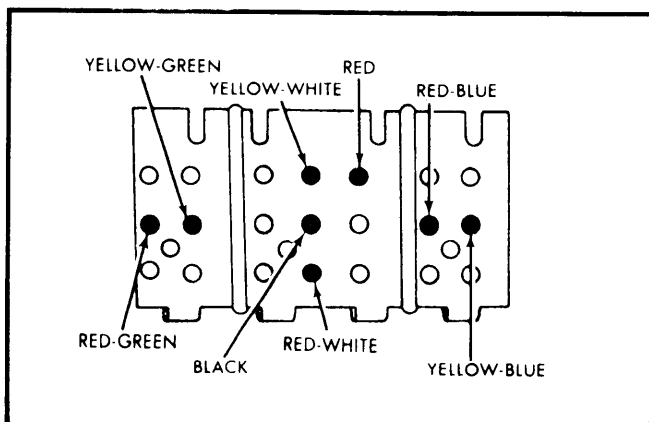

Fig. 1 Master Switch Connector Test Points

FRONT MOTOR

Connect a jumper lead between RED wire terminal in center section of connector and either the RED-GRN or YEL-GRN connection in front section (See Fig. 1). Connect another jumper wire between BLK wire terminal in center section and open connection in front section. If motor does not operate, reverse jumpers in front section. If motor still does not operate, either harness or complete three motor assembly should be replaced.

CENTER MOTOR

Connect a jumper lead between RED wire terminal of center section of connector and either the RED-WHT or YEL-WHT terminal of center section. Connect another jumper between BLK terminal and open terminal in center section (See Fig. 1). If motor does not operate, reverse RED-WHT and YEL-WHT jumper connections. If motor still does not operate, either harness or three motor assembly should be replaced.

REAR MOTOR

Connect a jumper lead between RED wire terminal in center section of connector and either the RED-BLU or YEL-BLU terminal in rear connector section. Connect another jumper between the BLK wire terminal in center section and open connection in rear section. If motor does not operate, reverse jumpers in rear section. If motor still does not operate, either harness or three motor assembly should be replaced.

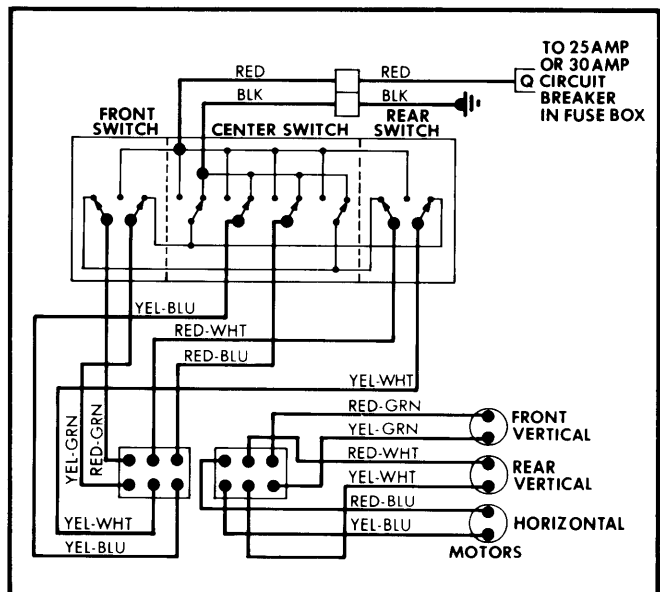

Fig. 2 Chrysler Power Seat Wiring Diagram

CONTROL SWITCH

If motors and seat operate properly when switch is by-passed during electrical tests, the switch is defective and should be replaced.

REMOVAL & INSTALLATION

CAUTION — Whenever a motor, cable housing assembly, or vertical and horizontal transmission assembly require maintenance, the assemblies must be synchronized to ensure proper operation.

MOTOR

Removal — Disconnect battery ground cable. Raise vehicle and remove mounting nuts holding seat assembly to floor pan. Disconnect wiring harness and remove seat assembly from vehicle. Remove bolt securing motor to support. Remove motor mounting screws (see Fig. 3). Disconnect housings and cables from motor assembly and remove motor.

CHRYSLER CORP. (Cont.)

Installation – Position motor onto support of seat assembly. Connect housings and cables to motor. Install and tighten motor mounting screws, and repeat this for bolt securing motor to support. Position seat assembly in vehicle and attach wiring harness. From underneath vehicle install and tighten floor pan mounting nuts to seat.

CABLE & HOUSING

Removal – It is recommended to remove motor assembly from seat, for ease of cable removal and installation. After motor removal, disconnect cable from motor, and clamp from cable housing (see Fig. 4). Slide cable and housing out of connector.

Installation – Insert cable and housing into connector. Synchronize motor and transmission. Install motor assembly and seat assembly in vehicle.

HORIZONTAL & VERTICAL TRANSMISSIONS

Transmissions are not removable and no maintenance is required. If transmission fails replace entire seat adjuster assembly.

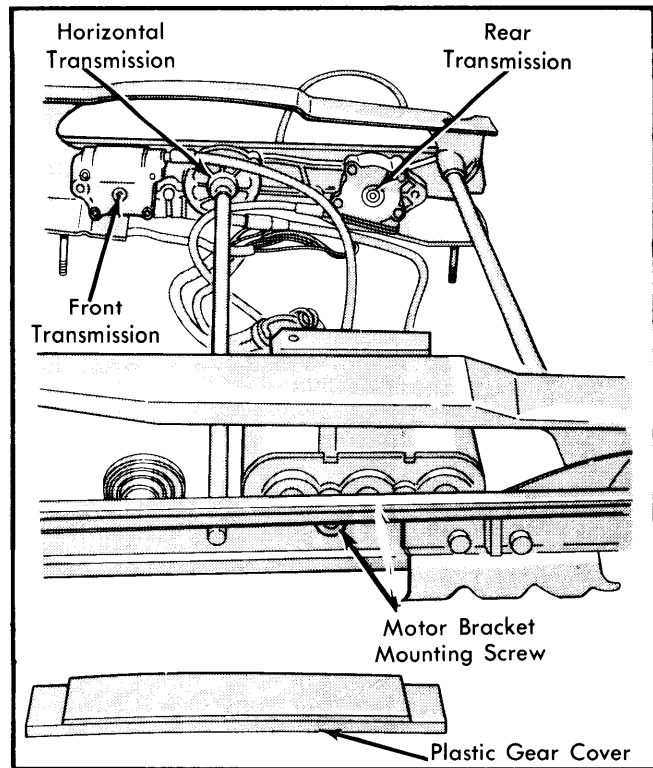

Fig. 3 Chrysler Seat Track Identification