

CHRYSLER CORP.

DESCRIPTION

Windshield wiper motors are two speed design. The systems park wiper blades in non-concealed or concealed (depressed park) positions depending on body style. Two speed motors are controlled by a third brush and resistor for low and high speed operation. All models have a two speed intermittent wiper as optional equipment which has a delay mode. The delay mode has a range of 2 to 15 seconds and is accomplished by a variable resistor in the panel switch controlled electrically by a relay. System provides an extra wipe after wash during delay mode, and an anti-streak park system.

Liftgate wiper motors are single speed design and include a washer system.

The 2-speed wiper on Horizon and Omni has a "pulse wipe" system. By depressing wiper control knob, intermittent wiper/washer action is activated until control knob is released.

TESTING

2-SPEED FUNCTIONAL TESTS

NOTE — Remove wiring harness connectors from wiper motor. Check mounting bolts to assure ground.

1) Low Speed Test — For Horizon, Omni, Volare and Aspen without intermittent wiper motor, connect a jumper wire between terminal "L" on motor and positive battery post. The motor should run. If it runs, proceed to step 2). If not, proceed to step 5).

For all other models and all models with intermittent wiper motor, make an additional connection from "P2" terminal to ground. Motor should run. If it runs, proceed to step 2). If not, proceed to step 5).

2) High Speed Test — Move jumper wire to terminal "H". Motor should run. If it runs, proceed to step 3). If not, proceed to step 5).

3) Park Test — For Horizon, Omni, Volare and Aspen, without intermittent wiper, connect a jumper wire between "P2" and "L" on wiper motor. Connect a second jumper wire from battery to "P1" terminal. Wipers should park. If OK, proceed to step 4). If not, proceed to step 5).

For all other models and all models with intermittent motor, connect a jumper wire between "L" and ground on motor. Connect a jumper wire from battery to "P1" terminal. Wipers should park. If OK, proceed to step 4). If not, proceed to step 5).

4) Wiper motor is good, check switch or wiring.

5) Motor is not functional, refer to System Tests before removing motor.

2-SPEED SYSTEM TESTS (INCLUDING INTERMITTENT MOTOR)

If wipers will not work in any switch position, turn switch to low speed and listen to the motor. If motor is running, check output shaft. If shaft is not turning, replace gearbox. If it is tur-

ning, check linkage connections. Replace any worn or damaged parts. If motor is not running, use a voltmeter or test lamp and check for 12 volts between motor terminal "L" and ground.

2-SPEED SYSTEM TESTS (INCLUDING INTERMITTENT MOTOR)

1) If voltage is present and panel switch circuit breaker is not cycling, check for an open circuit at the following locations. On Horizon, Omni, Volare and Aspen, insure ground strap connections are good. On all other models, connect a jumper between terminal "P2" and ground. If motor runs, panel switch is faulty or wiring to switch is open. Problem may also be poor contact of common brush to commutator, or an open circuit in armature.

2) If test lamp lights or 12 volts is present only part of the time, the circuit breaker is cycling. Problem may be a faulty circuit breaker or a short in the wiring, motor, or switch panel. Check these conditions with an ammeter and with wiper arms and blades removed.

3) Disconnect harness connector at motor, connect ammeter between battery and terminal "L". Also on all models except Horizon, Omni, Volare and Aspen, connect a jumper wire between terminal "P2" and ground. If motor runs with average ammeter reading below six amperes, motor is good and trouble is in switch panel or wiring.

4) If motor does not run and draw is more than six amps., check wiper linkage for binding. Disconnect drive link from motor. If motor runs and draws less than three amperes, repair linkage. If motor fails to run or draws more than three amperes, check motor gearbox for internal jamming. If no internal jamming exists, check motor for brush leads shorting to housing or armature for burned or blackened windings which could indicate an internal short.

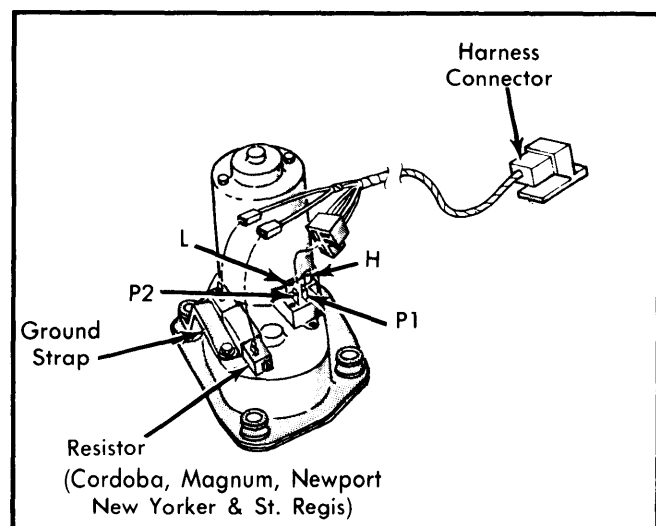

Fig. 1 Chrysler 2-Speed Motor Terminal Identification

Wiper/Washer Systems

CHRYSLER CORP. (Cont.)

5) If after several minutes test light or voltage does not appear at terminal "L", and circuit breaker is not cycling, disconnect harness and connect jumper from battery to terminal "L". On all models except Horizon, Omni, Volare and Aspen, also connect a jumper wire between "P2" and ground. If motor now runs, wiring or switch panel is faulty.

2-SPEED SYSTEM TESTS (INTERMITTENT ONLY)

1) If wipers run without delay and switch is in delay position check continuity between switch terminal and ground. Constant continuity or constant open, replace gear box assembly.

2) If wipers will not run with switch in delay position, disconnect connector from intermittent wipe control unit. Place switch in maximum delay and check voltage between positions "4" and "6" in terminal junctions. If voltage reads zero check panel switch and wiring. If reading is 10 to 15 volts replace control unit. If wipers operate, but will not operate after placing switch in delay position, check voltage between positions "4" and "8" and follow same procedures as above. If wipers fail to operate continually when wash control is operated during delay mode, check voltage between positions "4" and "7" and follow same procedures as above.

2-SPEED SWITCH PANEL TESTS

Remove switch from vehicle and using a continuity tester or ohmmeter, test continuity between terminals as indicated in table. For test purposes use the switch case for ground, the first position for OFF, the first detent past off for LOW, and the second detent past off for HIGH.

2-Speed Switch Panel Continuity

Test Connections

Switch Position	Non-Concealed Wipers	Concealed Wipers
Off	B to B/U	B to P
	B to P1	A to Ground
	A to P2	F2 Open
	H Open	H Open
Low	B to B/U	B to A
	B to P1	F2 to Ground
	B to A	P Open
	P2 Open	H Open
High	H Open	H Open
	B to B/U	B to H
	B to P1	F2 to Ground
	B to H	P Open
P2 Open	P2 Open	A Open
	A Open	

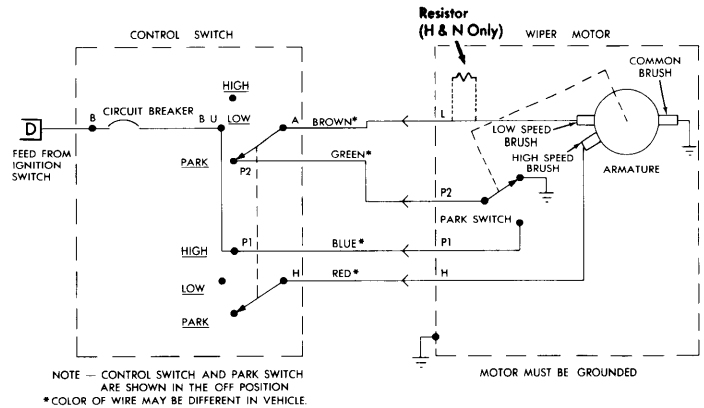

Fig. 2 Chrysler 2-Speed Non-Concealed Wiper Motor Wiring Diagram

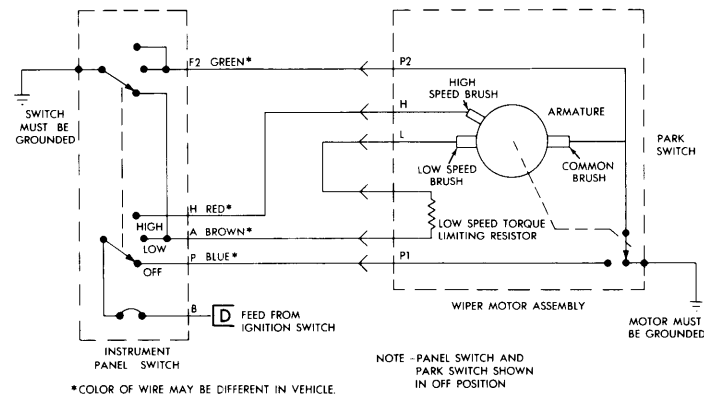

Fig. 3 Chrysler 2-Speed Concealed Wiper Motor Wiring Diagram

2-SPEED SWITCH PANEL TESTS (INTERMITTENT)

Remove switch from vehicle and using an ohmmeter test for continuity between terminals as indicated in chart. Battery is not required, ground is case of switch.

2-Speed Intermittent Switch Panel Continuity Chart			
Off	Delay	Low	High
B-P1 A-G	B-L1 ① R-Through variable Resistor 11 P2-G	B-A P2-G	B-A ② P2-Through Diode-G H-G

- ① — Resistance at maximum delay position should be between 270,000 and 330,000 ohms.
- ② — Resistance at minimum delay position with ohmmeter set on the high scale and positive of ohmmeter connected to "P2" and negative connected to "G" should show low or zero resistance. Reverse ohmmeter leads and an open circuit or very high resistance should be indicated. Same reading in both tests indicates a defective switch.

CHRYSLER CORP (Cont.)

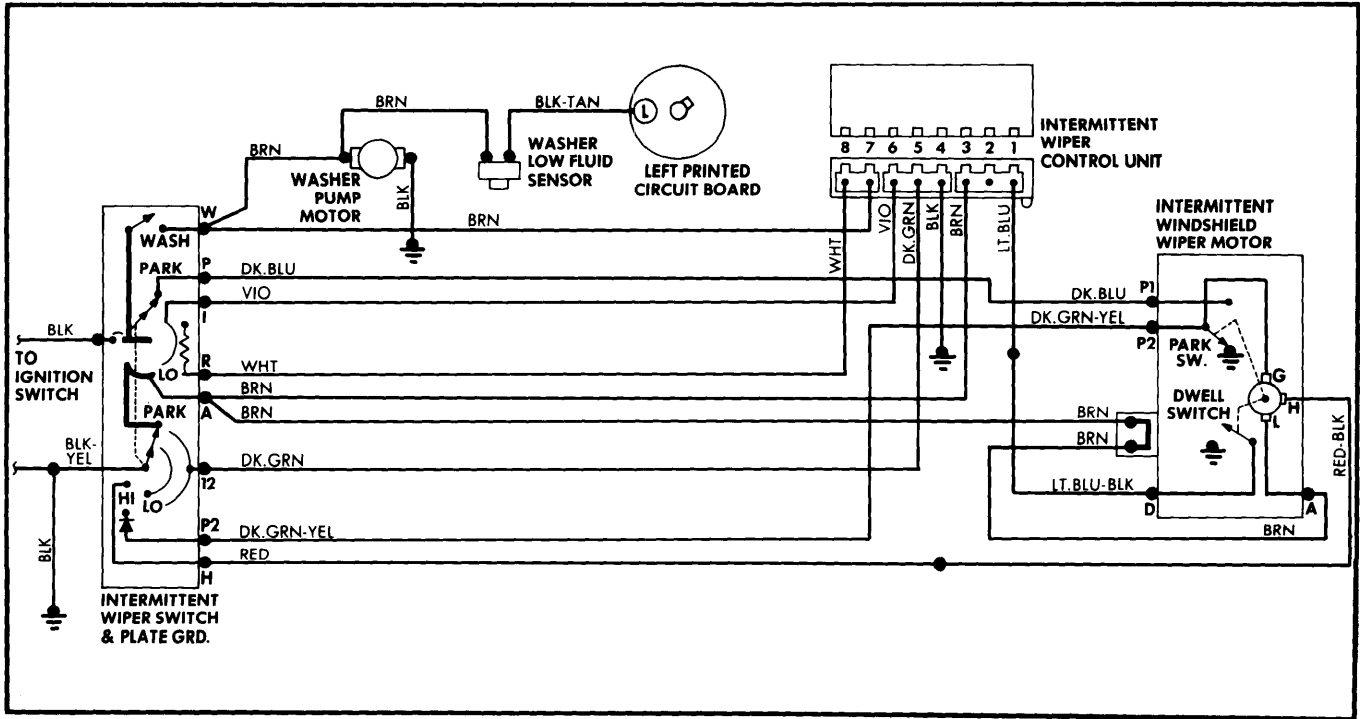

Fig. 4 Chrysler 2-Speed Motor Intermittent Wiper System Wiring Diagram

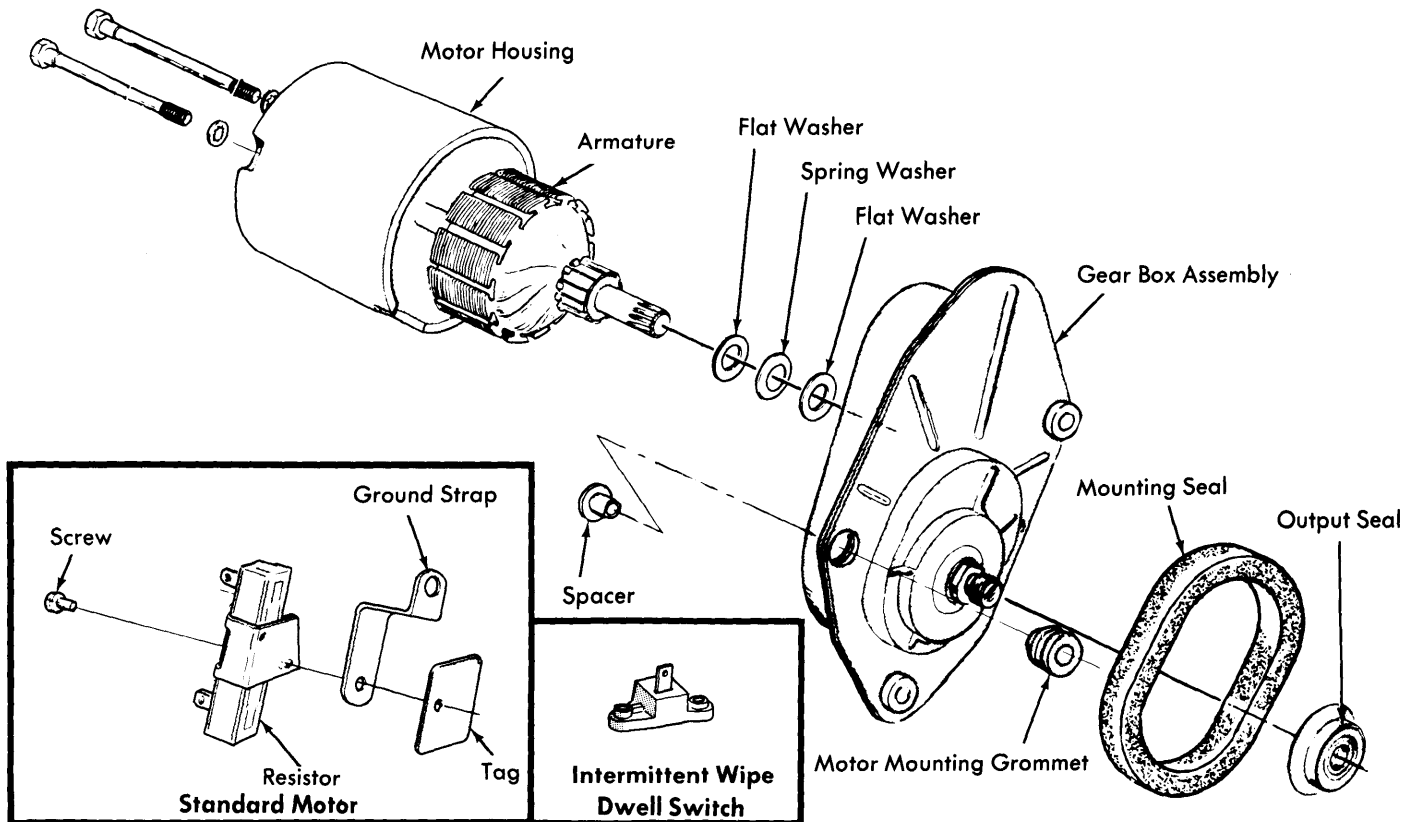

Fig. 5 2-Speed Wiper Motor (Exploded View)

CHRYSLER CORP (Cont.)

SINGLE SPEED LIFTGATE TESTS

- 1) Remove plastic cover and feed connector. With key and wiper switch in "ON" position, check battery voltage at Blue and Brown wires.
- 2) If voltage is 12 volts, apply voltage to terminal on switch plate.
- 3) If motor runs and drive shaft rotates, replace switch plate. If motor does not operate, replace motor assembly.
- 4) If motor operates but drive shaft does not rotate, check drive gear, drive shaft and link and repair or replace defective parts.

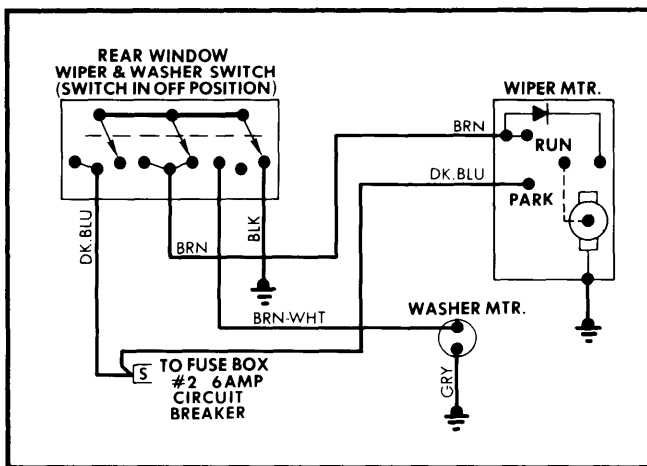

Fig. 6 Chrysler Tailgate Wiper System Wiring Diagram

REMOVAL & INSTALLATION

2-SPEED MOTOR (NON-CONCEALED WIPERS)

Removal — Disconnect battery ground cable and motor wiring harness. Remove motor mounting nuts. On vehicles without air conditioning, remove crank arm nut and crank arm from under instrument panel. On vehicles with air conditioning, work motor off mounting studs enough to gain access to crank arm mounting nut. **NOTE** — Do not force motor from mounting studs or drive link may be damaged. Hold motor crank with wrench while removing crank arm nut from crank, then pry crank arm from shaft. Remove motor.

Installation — Reverse removal procedure and note the following: Ensure three spacers are inserted in motor grommets and that crank arm is held with a wrench while tightening crank arm nut to 95 INCH lbs.

2-SPEED MOTOR

(CONCEALED AND INTERMITTENT WIPERS)

Removal — Disconnect battery ground cable, wiper arm and blade assemblies and cowl screen. Hold motor crank with wrench, remove crank arm nut and crank arm from motor. Disconnect wiring harness and remove motor mounting nuts and motor.

Installation — Reverse removal procedure and note the following: Insure rubber gasket and spacers between dash and motor are properly positioned. Hold crank arm with wrench while tightening crank arm nut to 95 INCH lbs.

SINGLE SPEED LIFTGATE MOTOR

Removal — Remove cover, arm assembly and pivot shaft assembly. Disconnect feed connector, remove screws and motor.

Installation — Reverse removal procedure. Tighten crank arm nut to 95 INCH lbs.

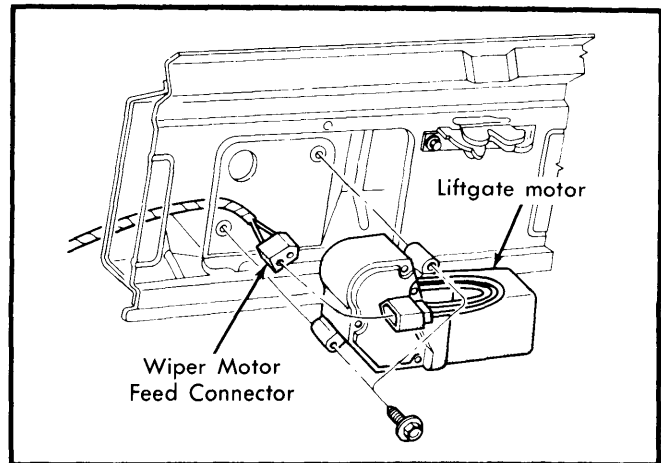

Fig. 7 View Showing Removal of Liftgate Motor