

## FORD MOTOR CO.

Ford Motor Co.  
All Models

### DESCRIPTION

#### NON-DEPRESSED PARK WIPERS

**Versailles, Monarch, Granada, Capri, Pinto, Bobcat, Fairmont, Zephyr & Mustang** – Wipers are actuated by permanent magnet, rotary type motor. Two wiper arms and blades are mounted on a pivot shaft, one at each side of windshield. Pivot shafts are connected to the motor by linkage arms and attaching clips.

#### DEPRESSED PARK WIPERS

**All Other Models** – Wiper motor is a two speed permanent magnet depressed park type with brush end plate at one end of housing and a gear housing at the other end. The park switch is located in gear cover and park mechanism is located in output arm.

#### INTERMITTENT WIPER GOVERNOR

Intermittent operation of wiper motor is controlled by a variable resistor in the windshield wiper motor control switch in conjunction with the electronic governor. This allows for a variable pause between wiping cycles. For intermittent operation, the wiper switch is rotated to the left. The more left rotation the more resistance, thus more time is allowed between wipe cycles. On Ford, Mercury, Granada, Monarch and Versailles, the wiper switch knob slides to the right, with the first detent being the intermittent operation. After placing knob in intermittent position, rotate time control knob clockwise to increase the pause between wipe cycles.

### TESTING

#### WIPER MOTOR CURRENT DRAW

**Depressed Park** – Motor test can be performed on car with linkage disconnected or on bench. Connect ammeter as shown. Connect a jumper wire from battery negative post to low speed terminal on motor end plate and read current draw. Move jumper to high speed terminal and read current draw. In both cases, current draw should not exceed 3.5 Amps.

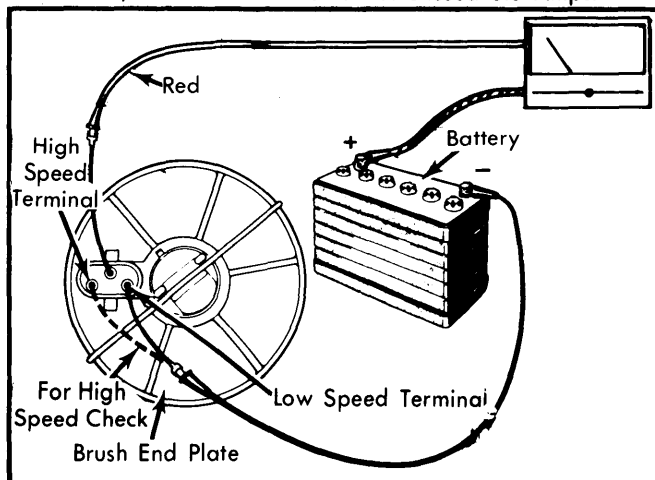

Fig. 1 Motor Current Draw Test

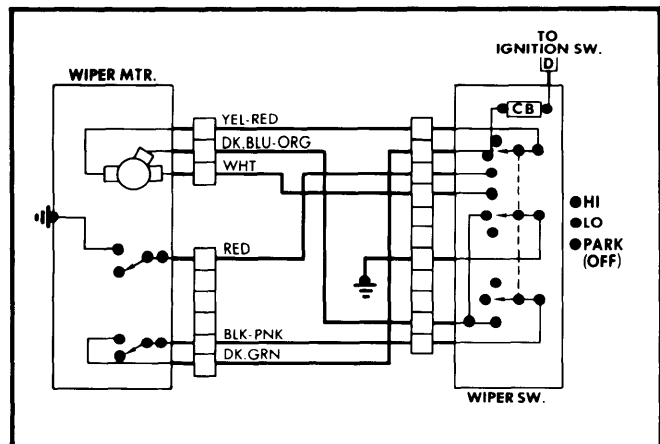

Fig. 2 Wiring Diagram 2-Speed Standard Depressed (Cougar, LTD II, Thunderbird, Rancho)

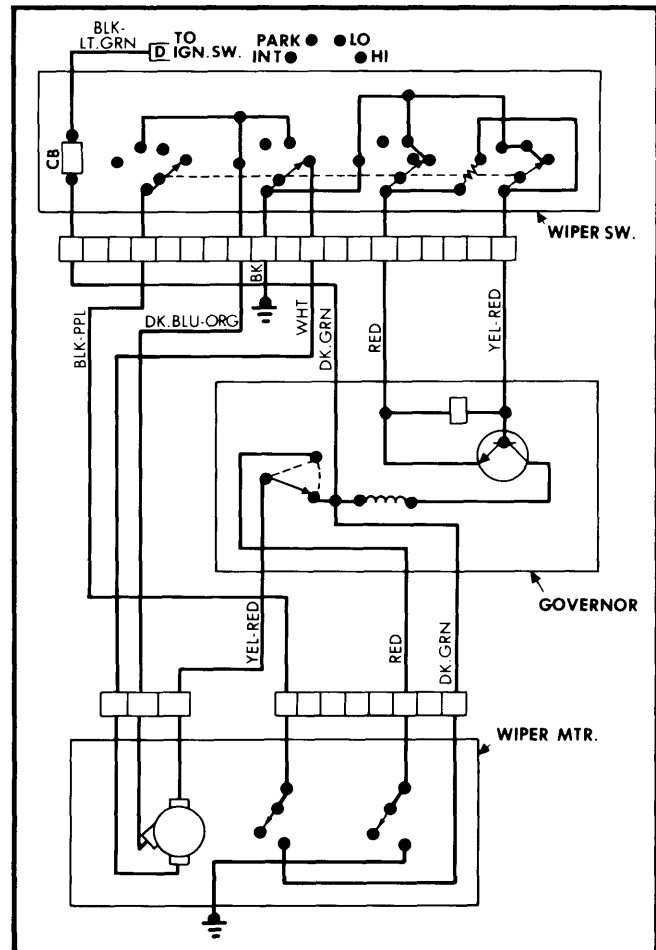

Fig. 3 Wiring Diagram 2-Speed Intermittent Depressed (Cougar, LTD II, Thunderbird, Rancho)

**Non-Depressed Park** – Disconnect battery. Disconnect linkage from motor, and disconnect electrical plug to test motor on vehicle. Connect meter as shown. Current draw in high and low speed should not exceed 3 Amps.

# Wiper/Washer Systems

## FORD MOTOR CO. (Cont.)

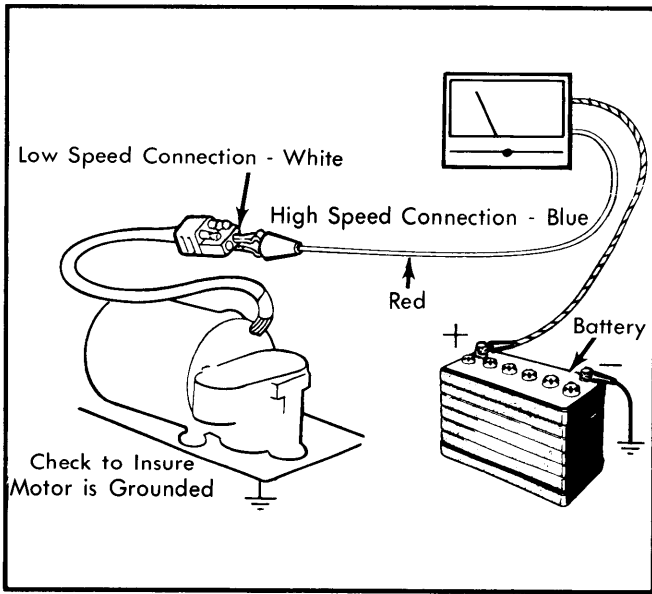

Fig. 4 Non-Depressed Motor Current Draw Test

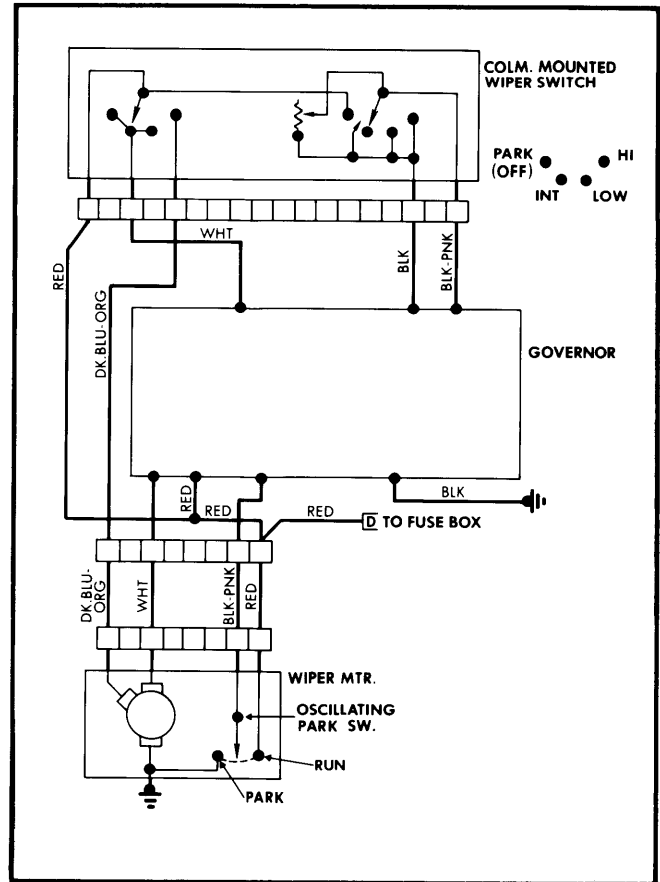

Fig. 6 Wiring Diagram 2-Speed Standard Non-Depressed (Granada, Monarch, Mustang, Capri, Fairmont, Zephyr)

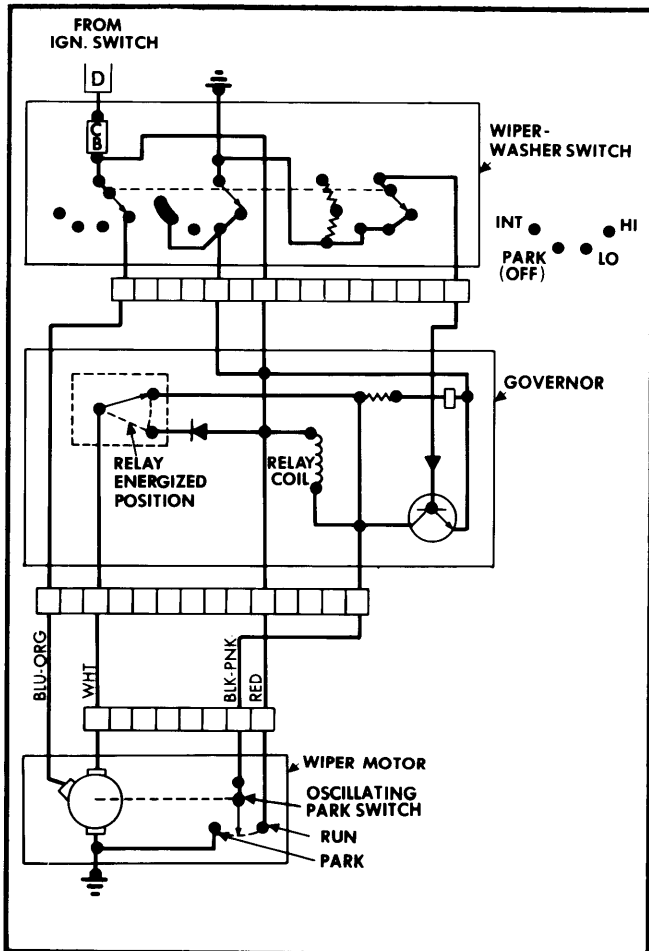

Fig. 5 Wiring Diagram 2-Speed Standard Non-Depressed - Pinto, Bobcat

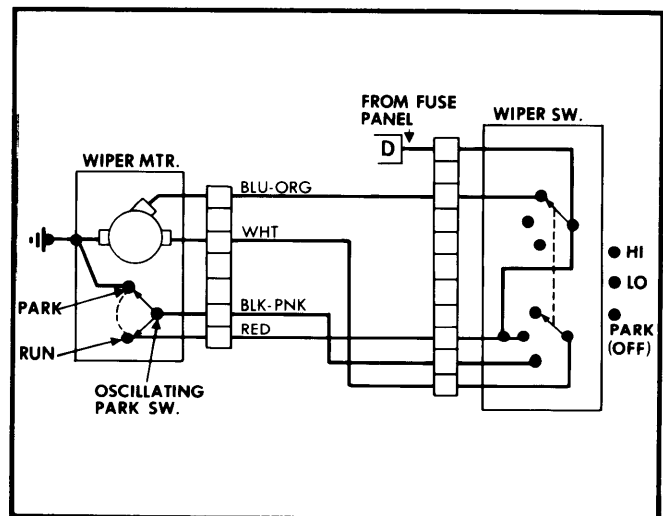
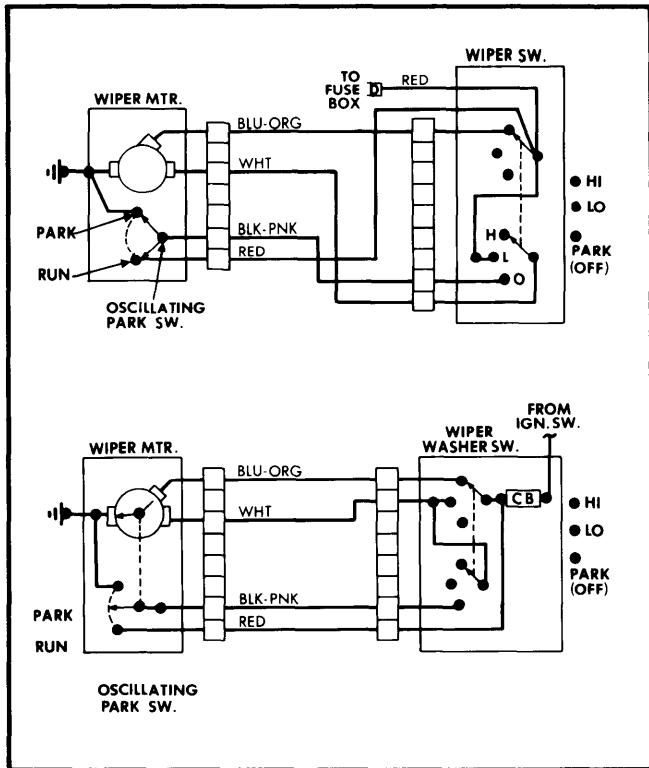

Fig. 7 Wiring Diagram 2-Speed Intermittent Non-Depressed - Pinto, Bobcat

# Wiper/Washer Systems

## FORD MOTOR CO. (Cont.)



**Fig. 8** Wiring Diagram 2-Speed Intermittent Non-Depressed (Granada, Monarch, Versailles)

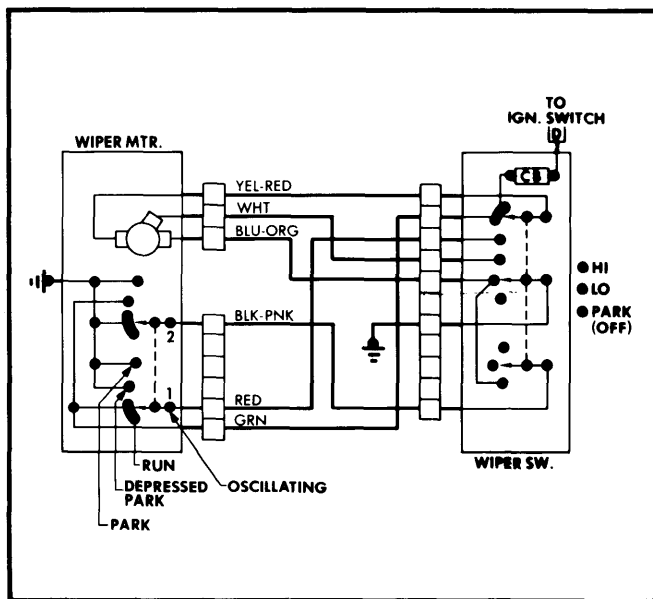

**Fig. 9** Wiring Diagram 2-Speed Depressed (Ford, Mercury)

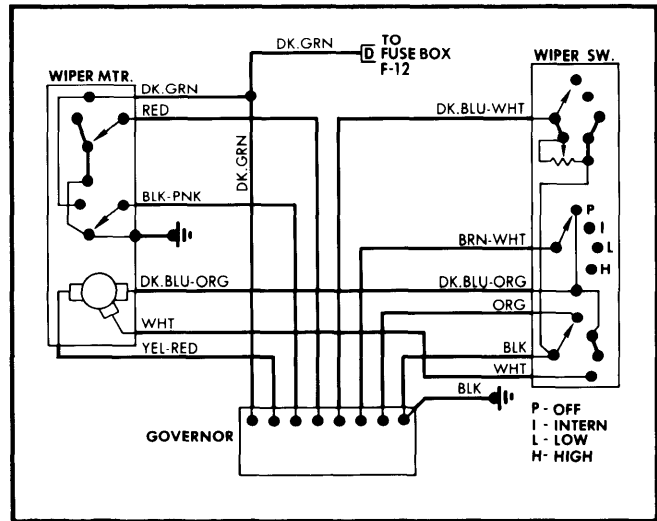

**Fig. 10** Wiring Diagram 2-Speed Intermittent (Ford, Mercury)

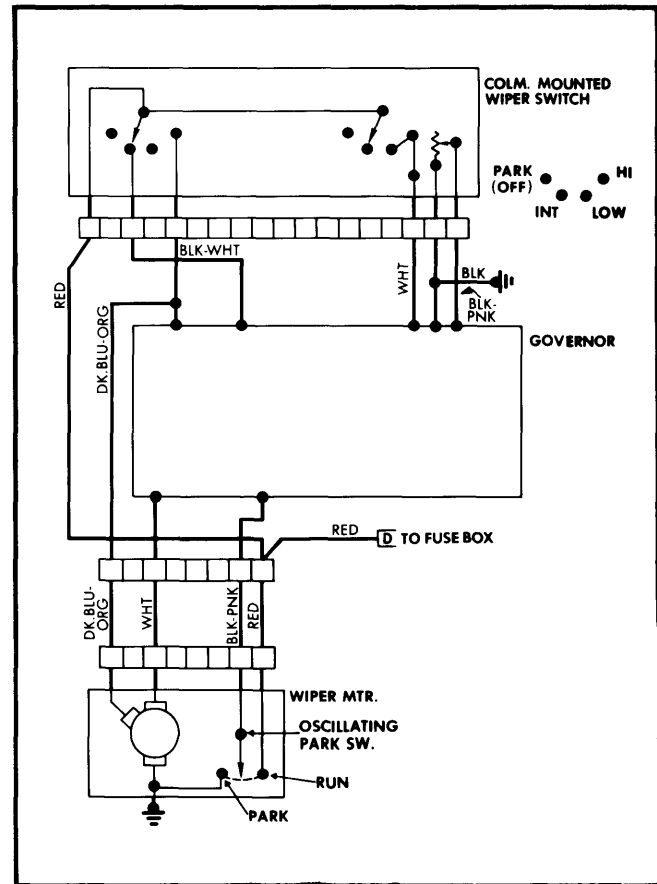

**Fig. 11** Wiring Diagram 2-Speed Intermittent (Fairmont, Zephyr, Mustang, Capri)

## FORD MOTOR CO. (Cont.)

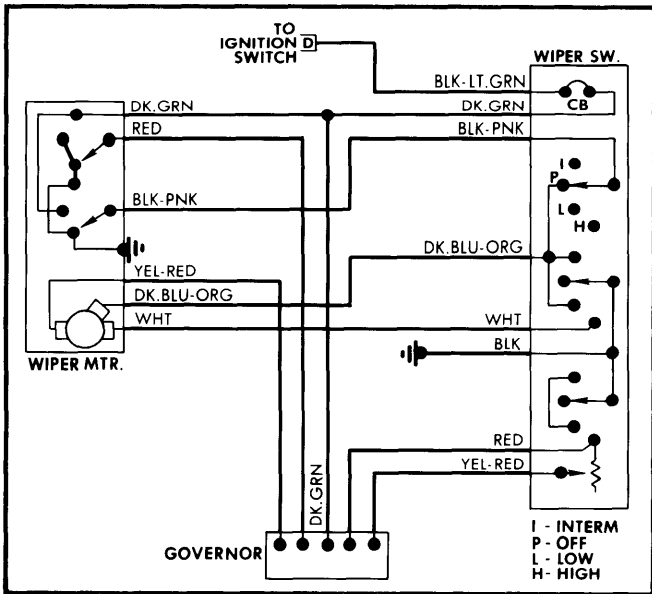

Fig. 12 Wiring Diagram 2-Speed Intermittent (Lincoln, Mark V)

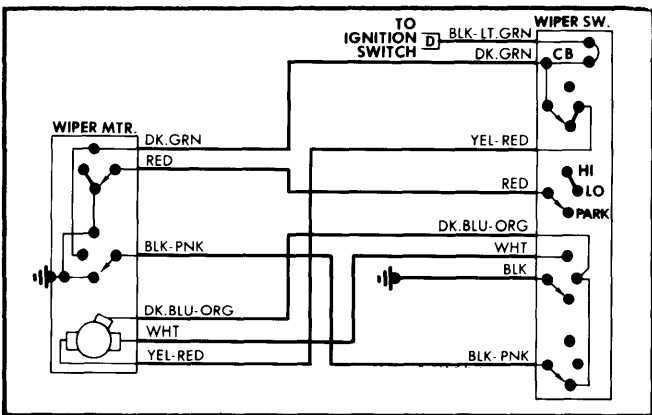

Fig. 13 Wiring Diagram 2-Speed Depressed (Lincoln, Mark V)

### CIRCUIT BREAKER

Circuit breaker is located in the wiper control switch on Lincoln, Mark V, Thunderbird, LTD II, Cougar, Pinto and Bobcat. All other models have a 6 amp. circuit breaker located in the fuse panel, except rotary pin terminal have 8 1/4 amps, rotary blade terminal switches have 7 amps. Slide switches have no circuit breakers.

Before connecting leads, short them together and adjust current draw so that it equals circuit breaker rating. Connect meter as shown. Leave breaker connected to meter for ten minutes. Current reading should remain at rated current. If circuit breaker opens during the ten minutes it should be replaced.

Now adjust current draw to twice the rated current. The current reading on the ammeter should drop to zero within 30 seconds. If it takes longer than 30 seconds for breaker to open, it should be replaced.

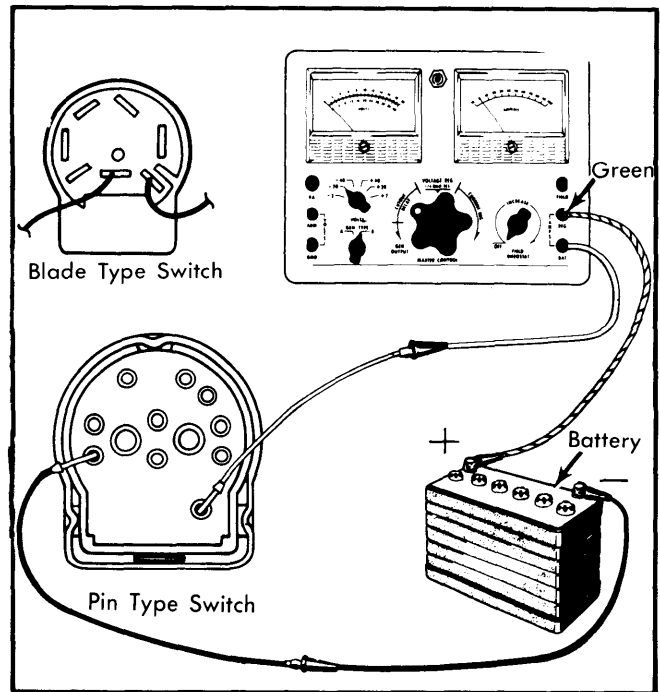

Fig. 14 Circuit Breaker Test

### WIPER MOTOR PARKING TEST

**Non-Depressed Park** - Stop wiper system with ignition switch so blades are not in park position. Connect jumper wires as shown. The wipers should not run more than one full cycle then park. If motor will not park, or will not run to park, replace motor.

**Depressed Park** - Stop output arm about 90° past park position for this test. Make electrical connections (see illustration). With this hookup, the motor output arm should move in the following cycle: Rotate in normal direction. Reverse direction of rotation for about 10-15°. Stop rotating while crank pin is moved radially outward in a semicircular motion. Then finally stop in park position with current draw going to zero.

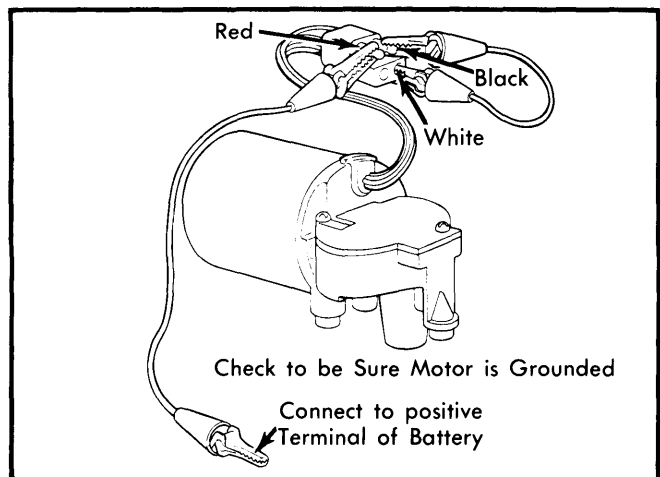

Fig. 15 Non-Depressed Motor Park Test

## FORD MOTOR CO. (Cont.)

If output arm rotates in the reverse direction more than 15°, or if the motor stalls or jams while the output arm is rotating in the reverse direction replace the arm and windlatch assembly with the appropriate kit. If the motor does not run or does not park, check wiring connections at motor before removing motor from vehicle. For any other deviation, replace the gear cover and switch assembly with appropriate kit.

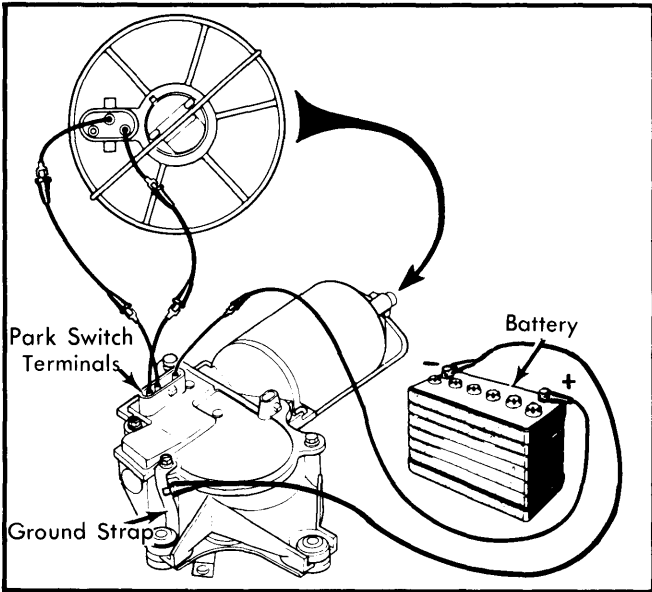

Fig. 16 Depressed Motor Park Test

### WIPER SWITCH CONTINUITY TEST

**All Models** – Check continuity between switch terminals as shown in Fig. 17 through 22. An ohmmeter must be used to test both systems. To detect marginal operation of the switch, move control knob while each reading is being taken. If switch does not indicate continuity as shown or poor continuity exists during movement, replace switch.

### WIPER SWITCH CONTINUITY TESTS

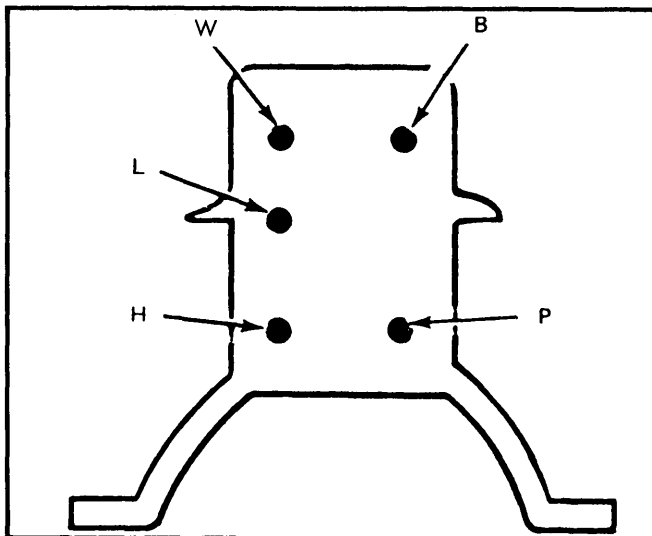

Fig. 17 Pin Type Switch Connector (Fairmont, Zephyr)

Switch Position	Terminal Continuity
Off (Park) .....	P-L
Low .....	B-L
High .....	B-H
Wash .....	B-W

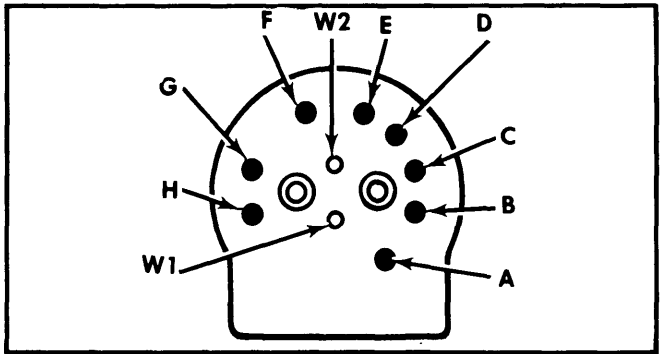

Fig. 18 Pin Type Switch Connector (Standard Wipers)

Switch Position	Terminal Continuity
Off (Park) .....	B-C, A-H, F-G
Low .....	C-D, A-G-H
High .....	D-E, A-G-H
Wash .....	W1-W2

### Intermittent Wipers

Off (Park) .....	B-C, A-H, F-G
Low .....	C-D-F-G, A-H
High .....	D-E-F-G, A-H
Intermittent .....	A-H, C-D-F-G
Wash .....	W1-2
Variable resistance between F and G: Minimum of between 100-900 ohms, to a maximum of 5,600-8,400 ohms.	

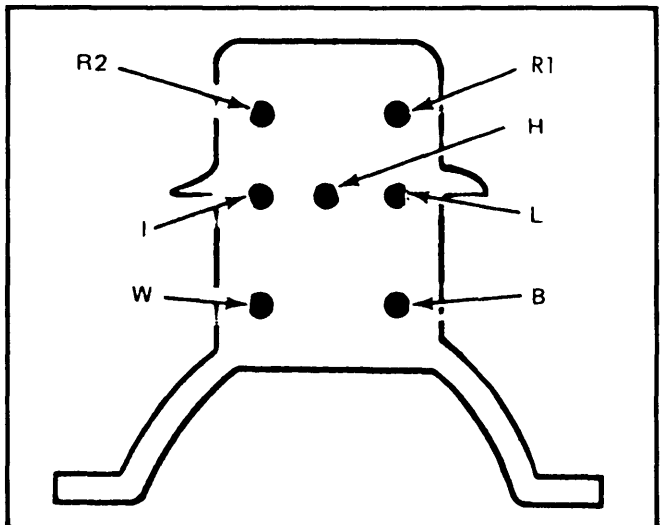

Fig. 19 Pin Type Interval Switch Connector (Fairmont, Zephyr)

# Wiper/Washer Systems

## FORD MOTOR CO. (Cont.)

Switch Position	Terminal Continuity
Ford Zephyr Interval Wiper- Off (Park)	B-H
Low	B-L
High	B-H-L
Intermittent	B-1
Wash	B-W

Variable resistance between R-1 and R-2: Minimum 300 ohms, Maximum 15,000 ohms. Fairmont and Zephyr only.

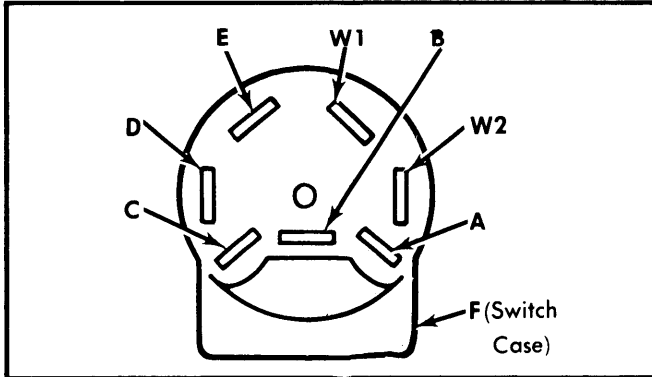

Fig. 20 Blade Type Switch Connector (Standard Wipers)

Switch Position	Terminal Continuity
Off (Park)	C-D, A-B
Low	A-B-C
High	A-B-E
Wash	W1-W2

**Intermittent Wipers**  
 Off (Park)..... A-B, D-E  
 Low ..... A-B, D-E-F  
 High ..... D-E-F, A-B-C  
 Intermittent..... E-F, A-B  
 Wash..... W1-W2  
 Variable resistance between D and E: Minimum of between 480-720 ohms, to a maximum of 5,600-8,400 ohms.

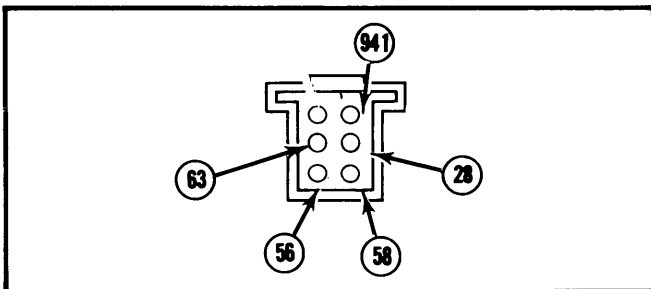

Fig. 21 Pin Type Connector Standard Wipers (Column Mounted Switch)

Switch Position	Terminal Continuity
Off (Park)	28-58
Low	58-63
High	63-56
Wash	941-63

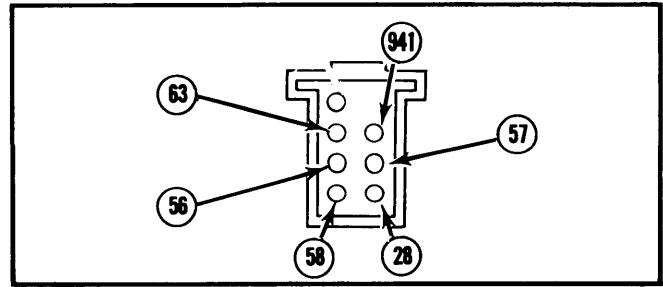

Fig. 22 Pin Type Connector Intermittent Wipers (Column Mounted Switch)

Switch Position	Terminal Continuity
Off (Park)	58-63, 28-63
Intermittent	58-63
Low	58-63, 28-57
High	63-56, 28-57
Wash	941-63

Variable resistance between 63 and 57 (switch off): Between 1,500 to 3,000 ohms minimum and 28,000 to 42,000 ohms maximum.

## REMOVAL & INSTALLATION

### WIPER MOTOR

**Removal (Depressed Park Type - All Models) - 1)** Disconnect the battery. Remove wiper arm and blade assemblies. Remove left cowl screen for access through cowl opening. Disconnect linkage drive arm from motor output arm crankpin by removing retaining clip.

**2)** From firewall, disconnect wire connectors from motor. Remove 3 bolts retaining motor-to-firewall, and remove motor. If output arm catches on firewall during removal, hand turn arm clockwise so it will clear opening.

**Installation -** Make certain output arm is in "PARK" position, then reverse removal procedure.

**Removal (Non-Depressed Park Type - Versailles, Monarch and Granada) - 1)** Disconnect battery ground cable. Remove instrument panel pad, speaker mounting bracket, defroster nozzle and air distribution duct.

**2)** Remove interlock module from bracket, disconnect connector and remove motor bracket-to-cowl bolts and drive arm link.

**Installation -** To install, reverse removal procedure.

**Removal (Non-Depressed Park Type - Fairmont and Zephyr) -** Disconnect battery. Remove left wiper arm and cowl top grille screws. Raise forward left corner of cowl, disconnect the linkage drive arm from motor output crank arm pin by removing retaining clip. Disconnect connector, remove mounting bolts and remove motor.

**Installation -** To install, reverse removal procedure.

## FORD MOTOR CO. (Cont.)

**Removal (Non-Depressed Park Type – Pinto, Bobcat, Mustang and Capri)** – Disconnect wiper pivot shaft and link assembly from motor drive arm ball. Remove 3 motor attaching screws and lower motor from under left side of instrument panel. Disconnect electrical leads and remove motor.

**Installation** – To install, reverse removal procedure.

### INTERMITTENT GOVERNOR

**Removal** – To locate the intermittent governor on vehicles, proceed as follows: Continental Mark V, remove the instrument panel pad. Lincoln Continental, Ford, Mercury, Fairmont, Zephyr, Granada, Monarch and Versailles, reach behind the left side of instrument. Pinto and Bobcat, remove fuse panel bracket and governor is mounted on back side. Cougar, LTD II and Thunderbird, remove 2 screws from under center of panel and lower governor.

**Installation** – To install, reverse removal procedure.

### WINDSHIELD WIPER SWITCH

**Removal (Continental, Thunderbird, Cougar, LTD II and Mark V)** – Disconnect battery. Remove switch knobs and bezel nut, then remove switch and connector. On Mark V,

remove cluster finish panel and wiper switch mounting plate. Disconnect wiring and remove switch.

**Installation** – To install, reverse removal procedure.

**Removal (Ford, Mercury, Pinto and Bobcat)** – Disconnect battery. Remove wiper and headlight switch knobs and bezel. Remove panel, switch retaining screws and switch from the rear.

**Installation** – To install, reverse removal procedure.

**Removal (Granada, Monarch and Versailles)** – Vehicles use an integral wiper/washer and turn signal arm which is removed from steering column using an Allen wrench or equivalent, to remove the retaining screw at base of arm.

**Installation** – To install, reverse removal procedure.

**Removal (Fairmont, Zephyr, Mustang and Capri)** – Remove steering column shroud attaching screws, grasp top and bottom of shroud and separate. Push connector off wiper switch with a flat screwdriver. Remove the 2 wiper switch attaching screws and remove switch.

**Installation** – To install, reverse removal procedure.