

## FORD MOTOR CO.

### DESCRIPTION

Power windows are operated by reversible type motors mounted with each individual window regulator. Each window has an individual switch for separate control. A master control switch is located on the left front door, and all windows may be controlled from this switch. A lock out switch is incorporated in the master switch and when actuated prevents window operation from the individual switches. A relay prevents window operation unless the ignition switch is in "ON" or "ACC" position.

Power vent windows are available on some models. The same power motor operates both the main and vent windows on these models.

### TESTING

#### WINDOW MOTOR

With motor and drive assembly removed from vehicle, connect a fully charged battery to motor with an ammeter connected in series. Current draw for this no load test should not exceed 5 amps. at 12.8 volts, and should not fluctuate. Reversal of battery connections will reverse motor rotation and current draw should be the same. Motor must be replaced if current draw exceeds specifications.

#### WINDOW SWITCHES

Testing is performed with a self-powered test light or an ohmmeter. Remove switch from vehicle before testing. See illustrations for switch terminal identification and continuity charts.

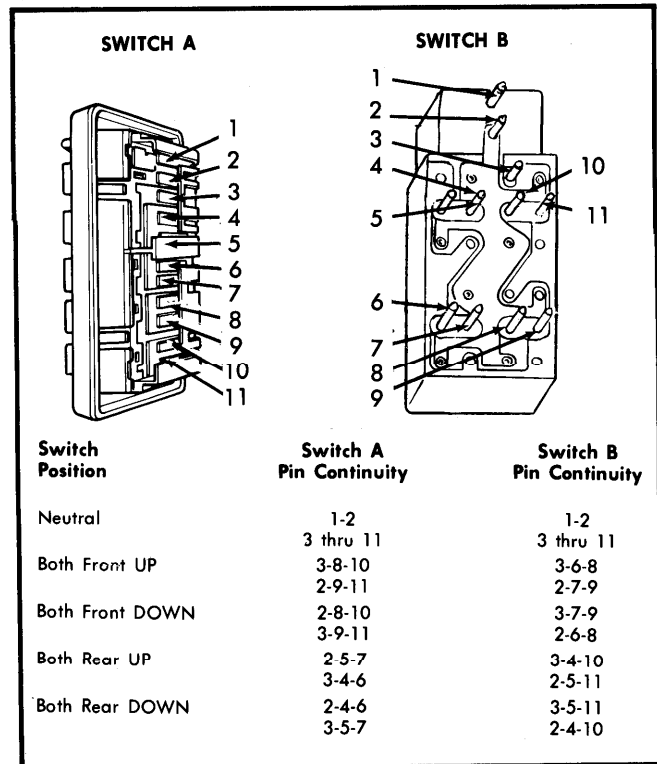

Fig. 1 4-Window Master Switch Testing (Including Mini-Vent Windows)

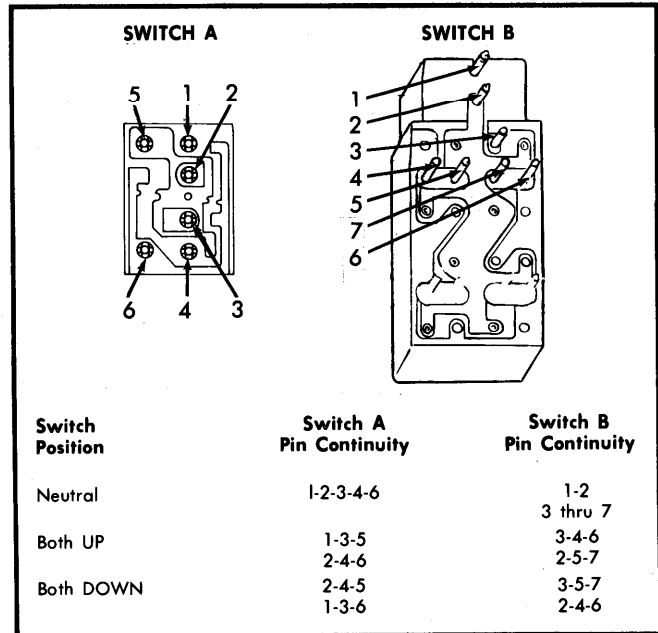

Fig. 2 2-Window Master Switch Testing

#### WINDOW RELAY

With one test lamp lead connected to relay output side and ignition in "ON" or "ACC" position, test lamp should light. If lamp does not light, check continuity of wiring harness from ignition switch to actuating terminal on relay. Check voltage at input terminal. If wiring and voltage are good, replace relay.

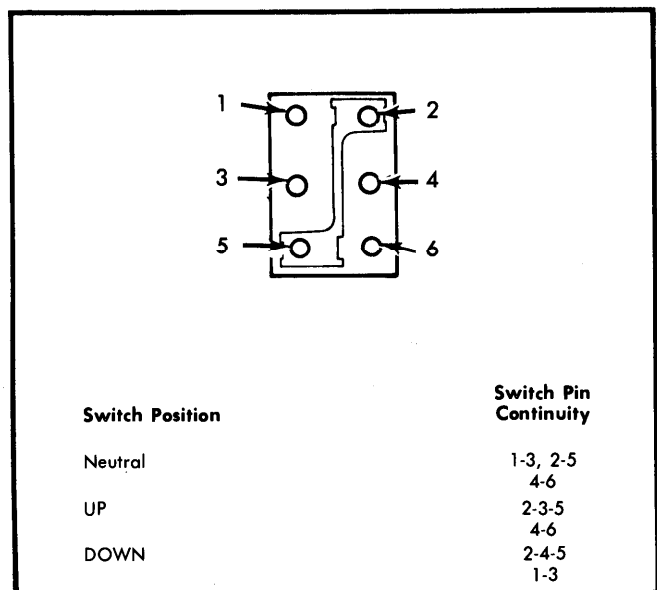
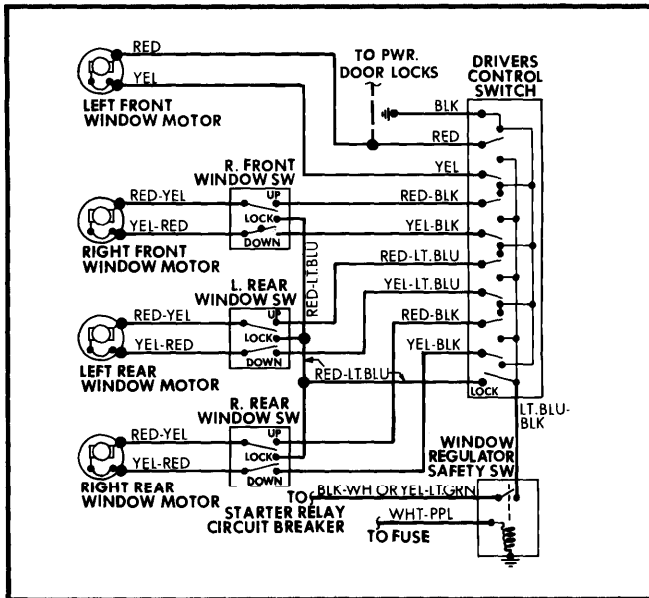

Fig. 3 Single Window Switch Testing

# Power Windows

FORD MOTOR CO. (Cont.)



**Fig. 4 Ford Power Window Wiring Diagram All 4-Door Models**

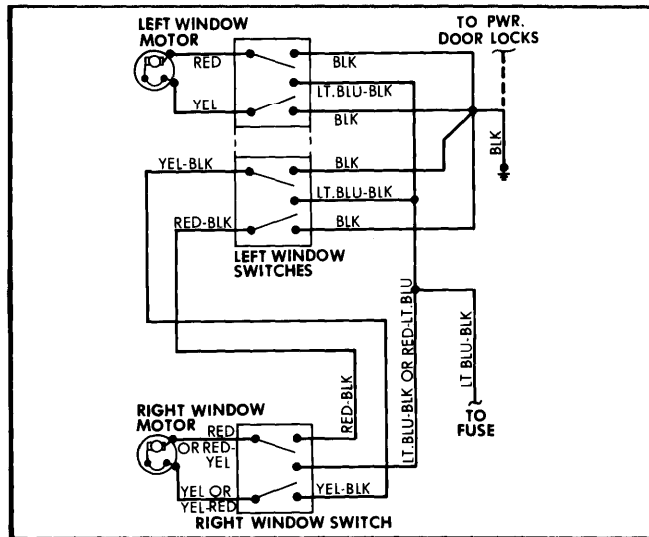

**Fig. 5 Ford Power Window Wiring Diagram Separate Master Switches**

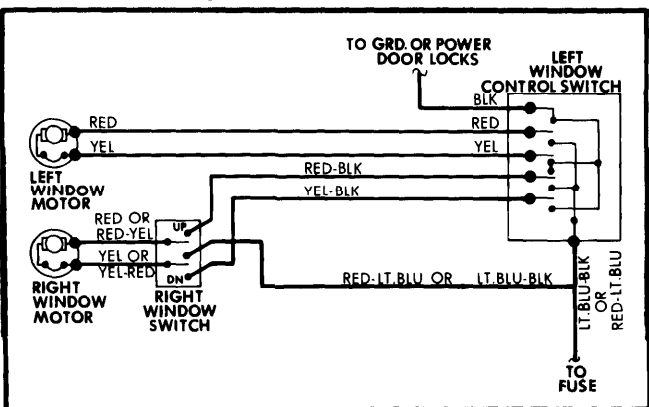

**Fig. 6 Ford Power Window Wiring Diagram Single Master Switch**

## REMOVAL & INSTALLATION

### POWER WINDOW SWITCH

**Removal (Arm Rest Switches Exc. Thunderbird and Cougar)** – Remove ash tray, remote mirror control, and bezel screws (if equipped). Lift bezel up enough to remove nuts or screws from bezel. Pry carefully to disconnect switch and wiring connector.

**Installation** – To install, reverse removal procedure.

**Removal (Arm Rest Switches on Thunderbird and Cougar)** – Remove inner door handle. Remove cover screws and rotate cover upwards and off. Remove switch housing screws, then switch-to-housing retaining screws. Separate switch from connector.

**Installation** – To install, reverse removal procedure.

**Removal (Door Panel Switches)** – Remove switch bezel screw (if present). Pry bezel from door panel, remove connector screws, and pry connector off switch.

**Installation** – To install, reverse removal procedure.

### DOOR WINDOW MOTOR & DRIVE

**NOTE** – For all models, remove trim panel, watershield and door mounted radio speakers (if equipped).

**Removal (All Exc. Fairmont and Zephyr Sport Coupe)** – If door is not equipped with access holes, drill  $\frac{3}{4}$ " holes where dimples are provided in door. If no dimples, use template supplied with replacement motor. Raise window and support, then remove motor mount bolts. Push motor toward outside of door to disengage, then remove. Disconnect wiring.

**Installation** – To install, reverse removal procedure, tighten motor screws to 50-85 INCH lbs., and cover holes with tape.

**Removal (Fairmont and Zephyr Sport Coupe)** – 1) Raise and support window. Drill out regulator rivets and disengage slider from window support. Move regulator to large access hole and clamp to door panel with 'C' clamp. Carefully release spring tension. See Fig. 7.

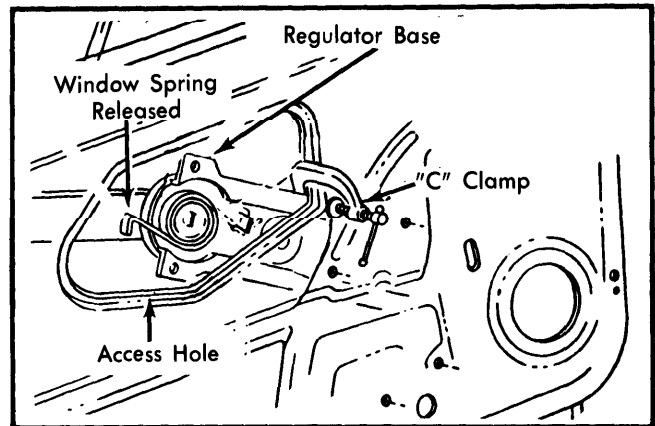

**Fig. 7 Window Regulator and Motor Removal Fairmont and Zephyr Sport Coupe**

## FORD MOTOR CO. (Cont.)

2) Remove "C" clamp, shift regulator to speaker hole, and clamp again to door panel. Remove motor screws and wiring, then remove motor.

**Installation** — To install, reverse removal procedure and tighten motor bolts to 50-85 INCH lbs. Refasten regulator with rivets or bolts.

### POWER MINI-VENT WINDOW MOTOR & DRIVE

**Removal** — 1) Remove trim panel and watershield. Prop vent and door glass in up position and disconnect wiring. Scribe reference marks at all screws and bolts before removal. Remove glass run bolts, loosen division bar bolts, and remove equalizer arm and cam nuts and screws.

2) Drill out rivets attaching regulator to door panel. Slide regulator rearward and remove rear guide from channel. Slide regulator forward and remove vent arm and front arm guides. Remove vent glass, push division bar clear, and remove regulator.

**Installation** — 1) Install front vent glass and regulator loosely. Lower main glass slightly and install guides into channels, then raise and prop up windows. Install glass run retainers loosely.

2) Install cam and equalizer arms at scribed marks. Bolt or rivet regulator securely. Tighten division bar fasteners. Connect wiring and lower windows slowly, and tighten front and rear run retainer screws at scribed marks. Test system for correct operation, then replace door panel.

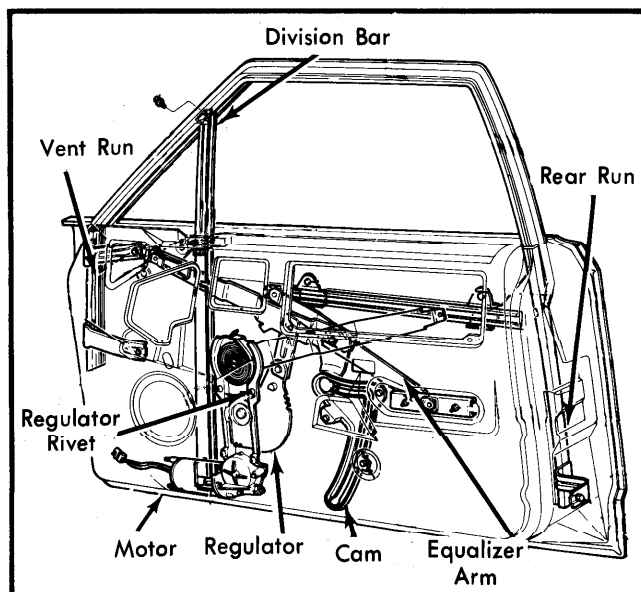

Fig. 8 Mini-Vent Window Mechanism