

## FORD MOTOR CO. TRACTION-LOK

**Ford Motor Co.**

*NOTE - Traction-Lok is used with Separate Housing Differentials only.*

(ignore initial starting torque). Torque should be at least 40 ft. lbs. Axle shaft should turn with even pressure without slipping or binding.

### DESCRIPTION

Traction-Lok (torque sensitive) locking differential employs a multiple disc clutch to control differential action. Shim(s), which control side gear mounting distance, four steel, four friction and one composite plate (steel on one side and friction material on the other) stacked on a clutch hub, and four ear guides are housed in the differential cover. Located in differential case between side gears is a one piece pre-load plate and block (four pinion) and four calibrated pre-load springs, which apply an initial force to clutch pack. Additional clutch capacity is derived from side gear thrust loads. The four friction plates are splined to clutch hub, which in turn is splined to left axle shaft, and the eared steel plates are dogged to the case.

### AXLE RATIO & IDENTIFICATION

See Ford Motor Co. Separate Housing in this section.

### TESTING ON CAR

Raise one wheel (other wheel must be on floor) and install a suitable tool and torque wrench on wheel mounting studs. With transmission in neutral, note torque required to keep wheel rotating throughout several revolutions

### REMOVAL & INSTALLATION

See Ford Motor Co. Separate Housing in this section.

### OVERHAUL

Procedures given are for Traction-Lok differential assembly only. For other axle components and specifications, see Ford Motor Co. Separate Housing in this section.

### DISASSEMBLY

1) Remove differential case from carrier and remove bearings from differential case in same manner as conventional case. Remove bolts securing ring gear, then remove ring gear by tapping with a soft hammer. Place differential case in a suitable press to load bearing journals so pre-load of springs is overcome (approximately 1500 lbs.). If a press is not available, two 7/16" bolts and nuts can be used in the ring gear mounting holes (one on each side) to compress case halves and overcome pre-load tension. While under pressure, loosen the two Allen or Phillips head screws which hold case halves together until one or two of the threads remain engaged. Remove case assembly from press. Tap on cover to spring it loose, then remove both screws.

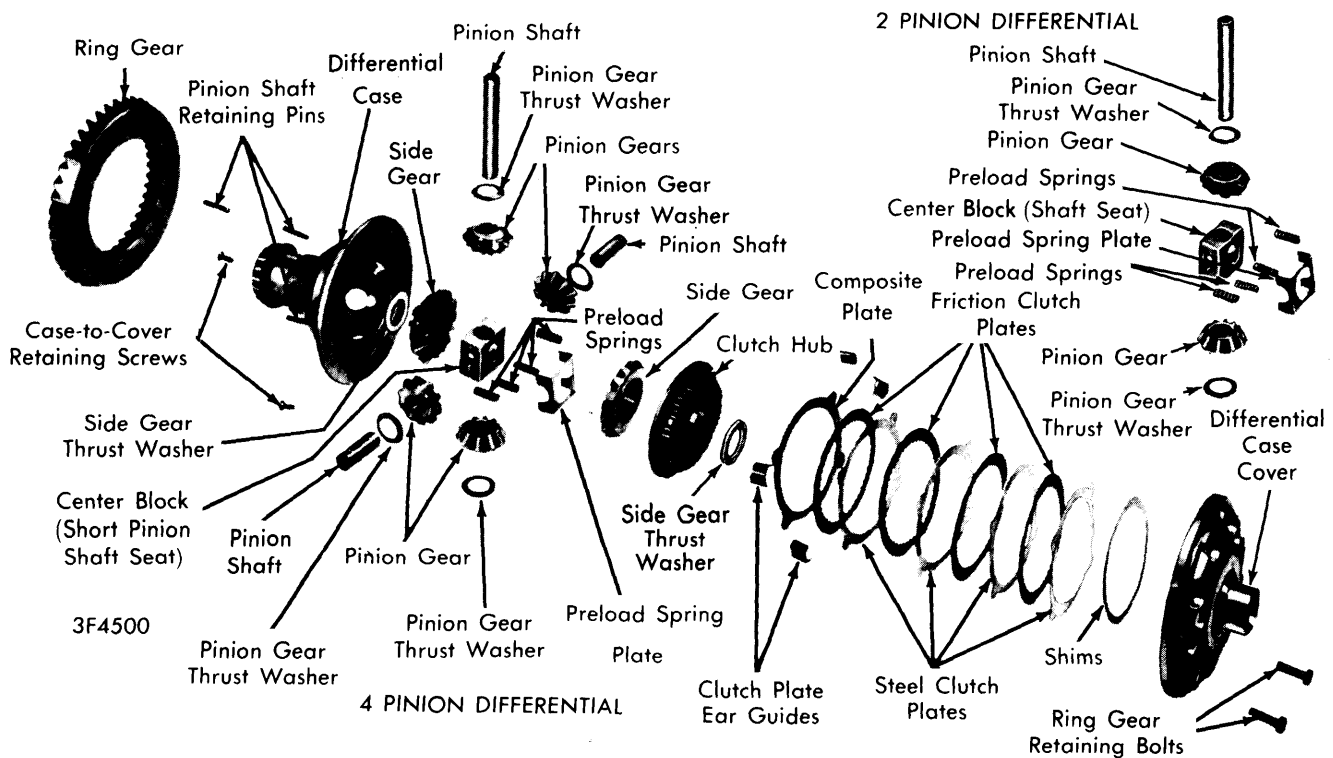

### TRACTION-LOK DIFFERENTIAL

## FORD MOTOR CO. TRACTION-LOK (Cont.)

2) With cover facing down, lift off case. Remove pre-load spring plate, and springs. From cover remove side gear, four clutch plate ear guides, clutch hub, friction and steel clutch plates and shim(s). With a drift drive out pinion shaft lock pins from case. Drive out long pinion shaft from case, drive from end opposite lock pin hole. Remove two short pinion shafts. Lift out center block, then remove pinion gears, thrust washers and side gear and thrust washer.

## INSPECTION

Inspect clutch plates for unevenness or wear. Dog-eared plates must be free of burrs, nicks or scratches. Inspect internally splined clutch plates for condition of bond, bonding material and wear. Replace bonded plates if thickness less than .085", or if badly worn or if internal teeth worn. Inspect all thrust surfaces and hubs for wear.

## REASSEMBLY

1) Lubricate all parts with hypoid lubricant. Mount differential case in soft jawed vise and place a side gear thrust washer and a side gear in counterbore of case. Install pinion thrust washers and place pinion gears on side gear, aligning holes in washers and gears with holes in case. Install center block so shaft holes are aligned with holes in pinion gears and case. Center block has two machined sides and two rough sides. With a brass drift, drive in long pinion shaft from outside of case aligning lock pin holes in shaft with holes in case. Center block should be positioned so long shaft is driven through rough side and short shafts driven through machined side.

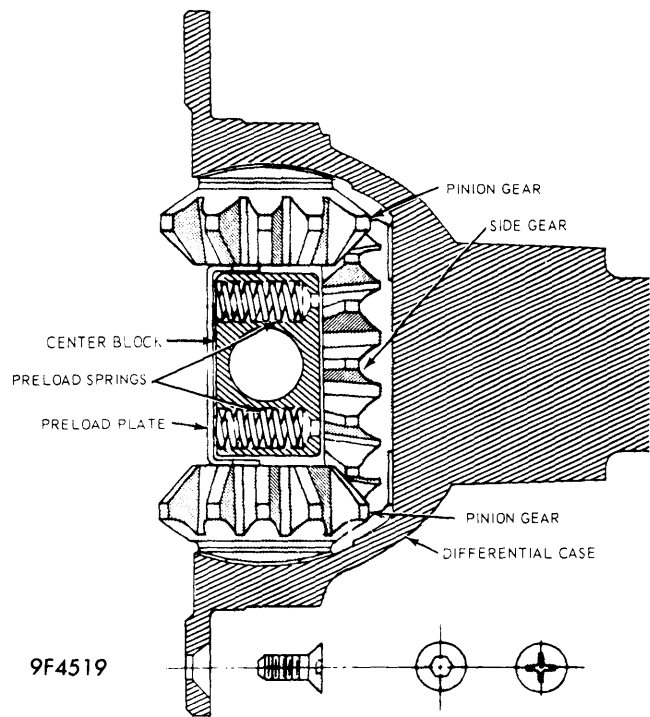

9F4519  
CENTER BLOCK & PRELOAD SPRINGS INSTALLATION

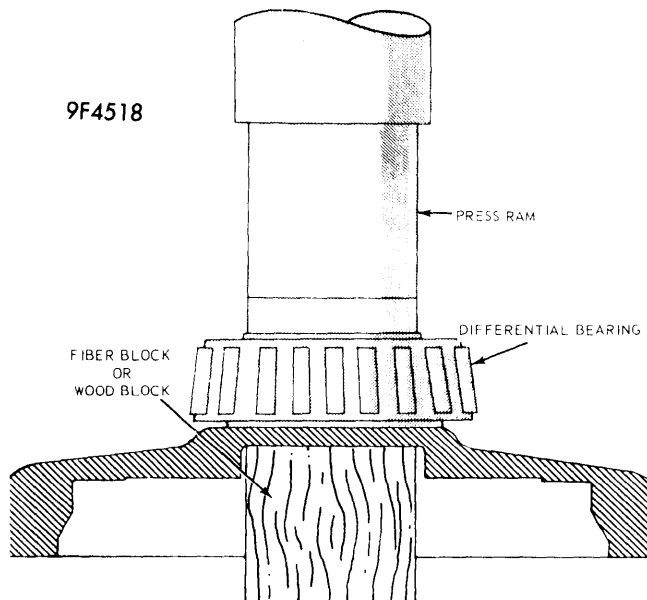

9F4518  
INSTALLING DIFFERENTIAL BEARING

2) Install shaft lock pins, making sure pinion and side gears move freely. Place four pre-load springs in holes provided in center block. Position a pre-load plate over the springs making sure springs are properly seated. Pre-load plate straddles center block over its narrower or machined width. Mount differential cover in soft jawed vise. Insert shim(s) of .050" total thickness in cover cavity. Install composite plate (friction material on one side and steel on the opposite) on back side of clutch

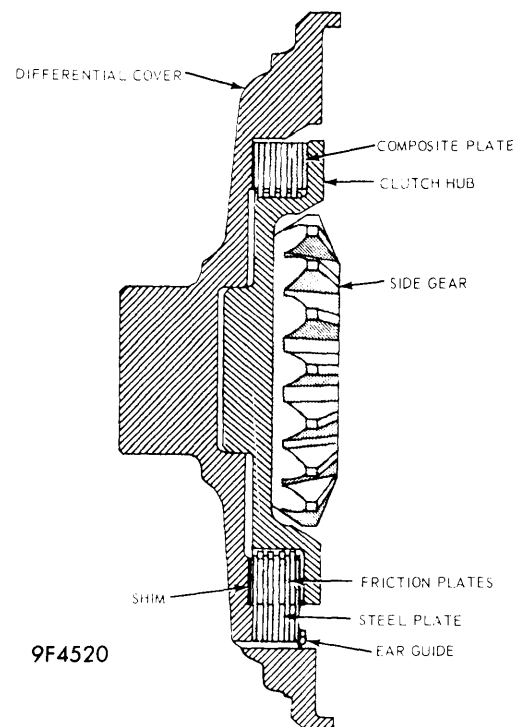

9F4520  
CLUTCH PACK INSTALLATION

hub with friction material against hub; next, install a friction plate, then steel, friction, steel, friction, steel, and lastly a steel plate. When new plates are used, soak in hypoid lubricant for 30 minutes before installation.

## FORD MOTOR CO. TRACTION-LOK (Cont.)

3) Place clutch hub with clutch plates into clutch ear cavities in differential cover, making sure splines on last friction plate are engaged on hub. Using a 5/8" x 2 1/2" bolt compress clutch pack and place shim template tool (T68P-4946-A) in clutch hub. Some clearance should be observed between shim tool and cover to ease mating surface, using a feeler gauge determine exact amount of clearance. Refer to shim pack thickness chart specifications which will indicate correct amount of shim(s) to subtract from .050" shim originally installed. In order to correctly select a proper shim(s), template tool must be used.

4) Install selected shim(s) in cover cavity, reinstall components as outlined in step 2 above. Install four steel clutch ear guides and side gear. Place both assemblies in a press, and press two halves together. Insert Allen or Phillips head screws and tighten evenly. Install ring gear and ring gear bolts, torque the bolts to 65-80 ft. lbs. Check torque required to rotate one side gear while the other is held stationary. Torque required to keep side

gear rotating with new clutch plates is 100-250 ft. lbs. With reused clutch plates, minimum torqued required is 40 ft. lbs. (Torque may fluctuate 10-40 ft. lbs.).

### SPECIFICATIONS

Feeler Gauge Reading Between	Remove Shim(s) From Nominal	Total Required Shim Pack Thickness
.001"-.002"	None	.050"
.003"-.007"	.005"	.045"
.008"-.012"	.010"	.040"
.013"-.017"	.015"	.035"
.018"-.022"	.020"	.030"
.023"-.027"	.025"	.025"
.028"-.032"	.030"	.020"
.033"-.037"	.035"	.015"
.038"-.042"	.040"	.010"
.043"-.047"	.045"	.005"
.048"-.050"	.050"	None

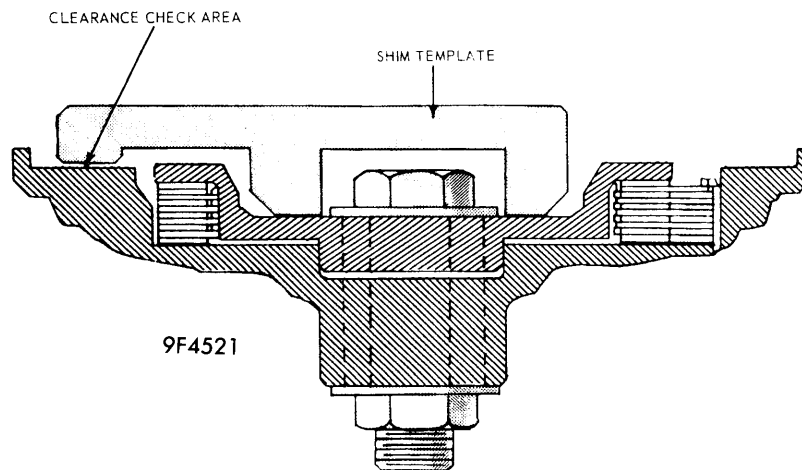

SHIM TEMPLATE TOOL APPLICATION