

General Motors V8 Engines

350", 400" & 455" PONTIAC, EXC. VENTURA

GENERAL SPECIFICATIONS						
Engine	Net HP At RPM	Torque (Ft. Lbs. at RPM)	Compr. Ratio	Bore	Stroke	Displ. Cu. Ins.
350" 2-Bbl.	155@4000	280@2000	7.6:1	3.880"	3.750"	350"
350" 4-Bbl.	175@4000	280@2000	7.6:1	3.880"	3.750"	350"
400" 2-Bbl.	170@4000	305@2000	7.6:1	4.120"	3.750"	400"
400" 4-Bbl.	185@3600	310@1600	7.6:1	4.120"	3.750"	400"
455" 4-Bbl.	200@3500	330@2000	7.6:1	4.150"	4.210"	455"

NOTE — Horsepower and Torque figures given above are NET. Net Horsepower and Torque represents power at the flywheel when the engine is installed in a vehicle, with wide open throttle and all systems operating such as; air cleaner, exhaust system, water pump, generator, oil pump and air conditioning.

ENGINE IDENTIFICATION

Engine code number is stamped on machined pad on right front side of engine.

Application

Code

350" 2-Bbl.	YA, YB, YP, YR
350" 4-Bbl.	ZX
400" 2-Bbl.	YC, YJ
400" 4-Bbl. (Federal)	WT, YS, YT, YY, Y6, Y7, ZA
400" 4-Bbl. (Calif.)	ZA, ZK
455" 4-Bbl. (Federal)	WX, Y3, Y4, Y8
455" 4-Bbl. (Calif.)	ZB, Z3, Z4

ENGINE REMOVAL

See Engine Removal at end of ENGINE Section.

INTAKE MANIFOLD

Removal — Drain cooling system. Remove hoses and thermostat housing. Disconnect wiring, vacuum hoses, fuel lines, and carburetor linkage. Remove carburetor and intake manifold as a unit.

Installation — Install new gaskets on cylinder heads and install manifold assembly. Install "O" ring seal between manifold and timing chain cover. Install manifold bolt loosely. Tighten intake manifold to timing chain cover bolt. Tighten other bolts evenly.

CYLINDER HEAD

Removal — 1) Remove intake manifold, push rod cover and rocker arm cover. Remove push rods and exhaust pipe to manifold attaching bolts (except left head of 455" S.D.). In order to remove head on 455" S.D., it will be necessary to remove exhaust manifold attaching nuts and drop manifold.

2) Remove battery ground strap, engine ground strap and oil level tube bracket on right head. Remove cylinder head bolts and remove head. **CAUTION** — Care must be taken when removing head bolts not to strike rocker arm studs. Studs are hardened and may crack if hit by wrench.

Installation — Three lengths of cylinder head bolts are used. When installed properly, all will project equally from their bosses. Tighten bolts evenly.

NOTE — Pontiac makes no recommendation as to cylinder head tightening sequence. It is suggested that cylinder head bolts be tightened in a circular pattern, beginning with the center bolt and working toward the ends alternately from end to end.

VALVES							
Engine & Valve	Head Diam.	Face Angle	Seat Angle	Seat Width	Stem Diameter	Stem Clearance	Valve Lift
350" & 400" ①							
Int.	1.96"	44°	45°	.045-.071"	.340"	.0016-.0033"
Exh.	1.66"	44°	45°	.048-.070"	.340"	.0021-.0038"
400" & 455" ②							
Int.	2.11"	29°	30°	.045-.071"	.340"	.0016-.0033"
Exh.	1.66"	44°	45°	.048-.070"	.340"	.0021-.0038"

① — Specifications are for 400" 2-Bbl. engine.

② — Specifications are for 400" 4-Bbl. engine.

350", 400" & 455" PONTIAC, EXC. VENTURA (Cont.)

VALVE ARRANGEMENT

E-I-I-E-E-I-I-E (both banks, front to rear).

available in .003" and .005" oversize. Valve seat must be refaced after reaming valve guide.

VALVE GUIDE SERVICING

Valve guides are integral with head. If valve stem to guide clearance is excessive, ream guide to proper size to accommodate oversize valve stems. Valves with oversize stems are

VALVE STEM OIL SEALS

Valve stem seals are installed in the 2nd groove (from end of stem). Special valve seal installer and tester tools are available. Where necessary, install new umbrella type seal, using plastic protector over end of valve stem.

VALVE SPRINGS					
Engine	Spring	PRESSURE (POUNDS) AT LENGTH (INCHES)			
		INTAKE		EXHAUST	
		Valve Closed	Valve Open	Valve Closed	Valve Open
350"	Outer	59.9-73.6@1.56"	124.7-138.7@1.18"	59.6-73.6@1.56"	130.8-144.8@1.15"
	Inner	33.3-53.3@1.52"	95.5-102.5@1.14"	33.3-43.3@1.52"	98.2-108.2@1.11"
400" 2-Bbl.	Outer	63.0-77.0@1.54"	128.1-142.1@1.16"	63.0-77.0@1.54"	134.6-148.6@1.12"
	Inner	36.4-46.4@1.50"	95.7-105.7@1.12"	36.4-46.4@1.50"	101.6-111.6@1.08"
400" 4-Bbl.	Outer	63.0-77.0@1.54"	128.1-142.1@1.13"	63.0-77.0@1.54"	133.8-147.8@1.12"
	Inner	36.4-46.4@1.50"	95.7-105.7@1.09"	36.4-46.4@1.50"	101.6-111.6@1.08"
455"	Outer	5.8-72.0@1.51"	128.8-142.8@1.16"	58.0-72.0@1.57"	134.6-148.6@1.53"
	Inner	31.4-41.4@1.53"	96.0-106.0@1.12"	31.5-41.5@1.53"	96.5-106.5@1.11"

VALVE SPRINGS

Removal — Remove rocker arm cover, spark plug, and distributor cap. Crank engine until distributor rotor is in position to fire on cylinder being serviced. Install suitable air fitting in spark plug hole and attach air line. Remove rocker arm. Thread suitable valve spring compressor stud (J8929-1) on rocker arm stud. Using suitable compressor (J6384-1) and nut (J8929-2), compress valve spring. Remove valve spring retainer cup locks, and remove compressor, valve spring and seal.

Installation — Install new parts and compress valve spring. Install seal and retainer cup locks. Remove compressor. Install rocker arm and tighten rocker arm ball retaining nut.

ROCKER ARM STUDS

Rocker arm studs are threaded type, screwed into threaded boss on cylinder head. If stud is damaged or threads are worn, remove stud with a deep well socket. Install new stud and tighten.

HYDRAULIC VALVE LIFTER ASSEMBLIES

NOTE — Lifters are serviced as complete assemblies only. Parts are not interchangeable between lifters. If any component of lifter is worn or damaged, complete lifter must be replaced.

If lifters are disassembled for cleaning and inspection, after reassembly they should be tested using a suitable leak-down tester. Leak-down rate is 20-90 seconds. Lifters must be replaced if they do not fall within limits.

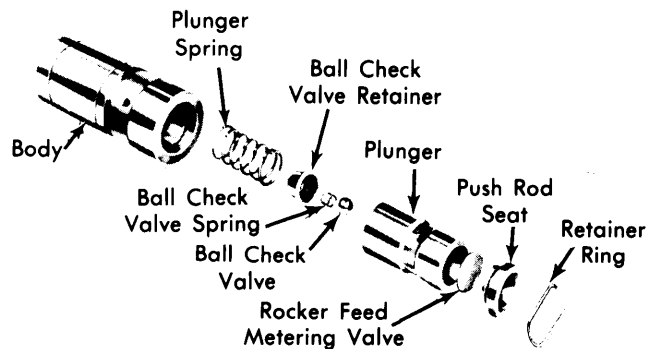

HYDRAULIC VALVE LIFTER ASSEMBLY

PISTONS, PINS, RINGS						
Engine	PISTONS		PINS		RINGS	
	① Clearance	Piston Fit	Rod Fit	Rings	End Gap	Side Clearance
350" & 400"	.0029-.0037"	.0003-.0005"	.0008-.0016"	1	.019"	.0015-.0035"
				2	.015"	.0015-.0035"
				3	.035"	.0015-.005"
455"	.0021-.0029"	.0003-.0005"	.0008-.0016"	1	.021"	.0015-.0035"
				2	.015"	.0015-.0035"
				3	.035"	.0015-.005"

① — Interference fit.

350", 400" & 455" PONTIAC, EXC. VENTURA (Cont.)

OIL PAN

See oil pan removal at end of engine section.

PISTON & ROD ASSEMBLY

Removal — With oil pan, oil baffle, oil pump and cylinder head removed, use a suitable ridge reamer to remove any ridge or deposits on upper end of cylinder bore. **NOTE** — Piston must be at bottom of stroke and covered with cloth to collect cuttings. Inspect connecting rods and caps for cylinder identification and mark as necessary. Remove rod cap and push rubber hose onto connecting rod bolts (to protect cylinder walls). Push piston and rod assembly out top of cylinder block. Install rod caps on mating rods.

Installation — When installing piston rings, make sure markings on compression rings face up (top of piston). Lightly coat pistons, rings and cylinder bores with motor oil. Compress piston rings using a suitable ring compressor. Install piston and rod assembly in cylinder bore, making sure notch in top of piston faces front of engine. Dimpled side (thrust side) of connecting rod must face forward for right bank and rearward for left bank. Lubricate bearing, install rod cap and tighten nuts.

FITTING PISTONS

Measure cylinder bore taper using a suitable cylinder gauge. Take several measurements parallel and at right angles to crankshaft, between ½" and 4" from top of cylinder. If taper exceeds .006", cylinder must be honed and a .001" or a .002" oversize piston installed. If correct fit of piston in cylinder bore still cannot be obtained, cylinders must be bored and oversize pistons and rings installed. Pistons and rings are available .010" and .030" oversize.

PISTON PINS

Removal — Using a suitable removal tool and a press, press piston pin out of piston and rod assembly. Separate piston from connecting rod.

Installation — If piston pin fit is not to specifications, in either piston or connecting rod, pin bore in piston and rod must be honed and oversize piston pins installed. Piston pins are available .001" and .003" oversize. When assembling piston and connecting rod, notch in top of piston must face front of engine. With notch facing forward, dimpled side (thrust side) of connecting rod must face forward for left bank and rearward for right bank. Lubricate piston pin and install using a suitable tool and a press.

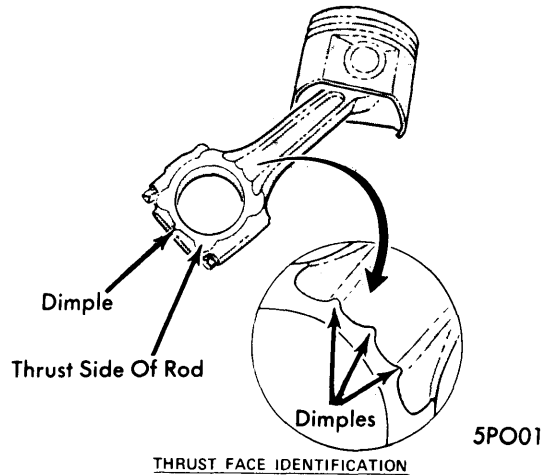

CONNECTING ROD THRUST SIDE IDENTIFICATION

CRANKSHAFT MAIN & CONNECTING ROD BEARINGS

Engine	MAIN BEARINGS				CONNECTING ROD BEARINGS		
	Journal Diam.	Clearance	Thrust Bearing	Crankshaft End Play	Journal Diam.	Clearance	Side Play
350" & 400"	3.000"	.0002-.0017"	No. 4	.003-.009"	2.250"	.0005-.0025"	.012-.017"
455"	3.250"	.0005-.0021"	No. 4	.003-.009"	2.250"	.0005-.0025"	.012-.017"

MAIN AND CONNECTING ROD BEARINGS

NOTE — Following procedures are performed with oil pan, oil baffle and oil pump removed.

Connecting Rod Bearings — After ensuring rod caps are marked for cylinder identification, remove rod caps (with crankshaft journal of cylinder to be checked at bottom of throw). Use Plastigage method to check for proper bearing clearances. New bearings are available in standard, .001" and .002" undersize. Selective fitting is required on each connecting rod. A standard bearing half may be used in combination with a .001" undersize or a .002" undersize in combination with a .001" undersize. Coat bearing surface with oil, install rod cap and tighten nuts. Rotate crankshaft after bearing replacement to ensure that bearings are not tight.

Main Bearing — 1) When checking main bearing clearance with engine in vehicle, place a .002" brass shim between

crankshaft journal and lower bearing in each bearing cap next to bearing being checked. Ensure that all cap bolts are tight and remove bearing cap of bearing to be checked. Use Plastigage method to check clearances. New bearings are available in standard, .001" and .002" undersize.

2) Remove upper main bearing by inserting suitable tool in oil hole of crankshaft journal and rotating crankshaft clockwise to roll bearing from engine. Oil new upper bearing and insert plain end of bearing at indented side of bearing seal and rotate crankshaft to install. Install lower bearing in cap so indentation in bearing and cap coincide. Install bearing cap and tighten bolts.

THRUST BEARING

With all main caps and connecting rods installed and torqued, tap end of crankshaft at rear until tight against front of thrust

350", 400" & 455" PONTIAC, EXC. VENTURA (Cont.)

bearing. Measure clearance between crankshaft counterweight and thrust bearing. If clearance is outside limits, (.003" to .009"), install new thrust bearing.

REAR MAIN BEARING OIL SEAL

1) Remove oil pan, oil pump and baffle. Remove rear main bearing cap and use suitable tool (see illustration) made from brass bar stock to pack upper seal. Insert tool against one end of oil seal in block and drive seal gently into groove until tool bottoms. Remove tool and repeat at other end of seal in cylinder block. Clean block and bearing cap parting line thoroughly.

2) Form a new seal in cap using suitable tool (J-7588). Remove new seal and cut four pieces approximately $\frac{3}{8}$ " long from this seal. Work two $\frac{3}{8}$ " pieces into each gap which has been made at end of seal in block. Without cutting ends, work seal pieces in until flush with parting line and no fibers are protruding over metal next to groove.

3) Form another new seal in cap using suitable tool (J-7588). Assemble cap to block and tighten. Remove cap and inspect parting line to insure that no seal material has been compressed between block and cap. Clean as necessary. Apply a $\frac{1}{16}$ " bead of sealer from center of seal to outer gasket groove. Reassemble cap and tighten.

ENGINE FRONT COVER

Removal - Drain radiator and cylinder block, loosen alternator adjusting bolts, remove fan and pulley, disconnect radiator hoses, remove fuel pump, remove harmonic balancer. Remove bolts attaching oil pan to cover. Remove cover.

Installation - Thoroughly clean gasket surfaces on block and cover, inspect oil pan gasket and replace if damaged. Use new "O" ring seal in water passage in intake manifold. Install and tighten cover-to-block and intake manifold bolts first, then install oil pan screws.

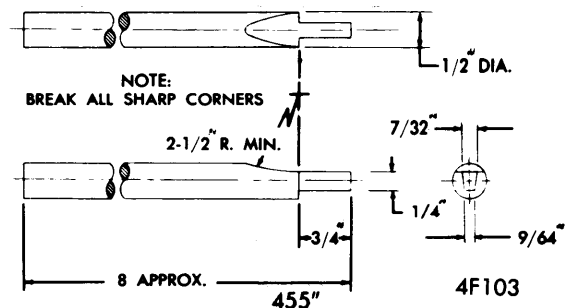
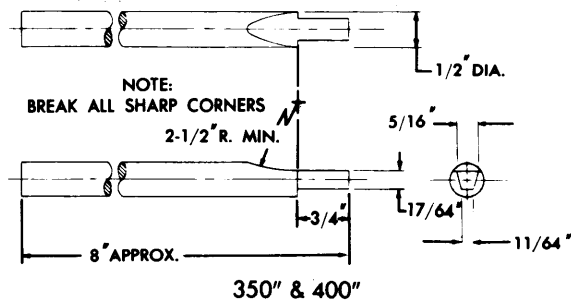

OIL SEAL INSTALLATION TOOL

FRONT COVER OIL SEAL

To replace seal, remove fan and accessory drive belts. Remove harmonic balancer. Remove seal by prying out of bore with pry bar. Using suitable tool, install new seal with lip of seal facing rear of engine.

CAMSHAFT			
Engine	Journal Diam.	Clearance	Lobe Lift
All	1.9000"

TIMING CHAIN

Removal - Remove timing chain cover, fuel pump eccentric and bushing. Remove timing chain cover oil seal. Align timing marks (see illustration) to simplify reassembly. If crankshaft sprocket is being replaced, remove using suitable puller (J-22888). Slide timing chain and sprockets off crankshaft and camshaft.

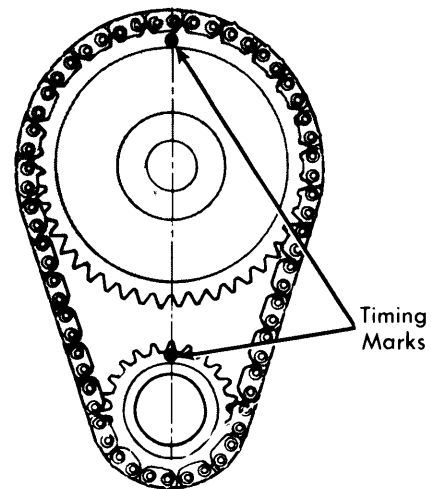

TIMING CHAIN SPROCKET ALIGNMENT

Installation - Install new timing chain and/or sprockets, ensuring that marks on timing sprockets are aligned exactly on a straight line passing through shaft centers. Camshaft should extend through sprocket so hole in fuel pump eccentric will locate on shaft.

CAMSHAFT

Removal - Camshaft may be removed without removing engine from vehicle using following procedure:

1) Drain cooling system, remove air cleaner and then disconnect all water and vacuum hoses, spark plug wires, carburetor linkage, fuel lines and wires to thermogauge unit. Remove hood latch brace and radiator. On vehicles equipped with A/C, remove alternator mounting bracket and alternator.

2) Remove crankcase ventilator hose and rocker arm covers. Remove distributor, intake manifold, push rod cover, push rods and valve lifters. Remove harmonic balancer, fuel pump timing chain cover, and timing chain and sprockets. Remove camshaft thrust plate and carefully pull camshaft from engine.

General Motors V8 Engines

350", 400" & 455" PONTIAC, EXC. VENTURA (Cont.)

Installation — To install, reverse removal procedure. **NOTE** — Before installation, coat camshaft lobes and inner diameters of bearings with heavy oil. Rotate camshaft several revolutions to ensure that it is free.

CAMSHAFT BEARING REPLACEMENT

Use suitable tool (J-6173) and note the following:

1) To replace rear bearing (without removing and disassembling engine) propeller shaft, transmission and clutch housing must be removed to get at camshaft rear plug. If front bearing is being replaced, insert remover adapter in center bearing to support shaft.

2) Outside of new bearing should be coated with oil before installation. Notch in edge of bearing is used to properly position bearing with respect to oil holes when installing. Index notch in edge of bearing with pin on replacer adapter. When bearings are installed in production, notches all face front except on rear bearing. In field service, all bearings should be installed with notches facing rear.

3) Rear bearing should be pulled in until front edge is flush with block to leave room for camshaft rear plug. Other bearings should be flush with both sides of bearing web.

ENGINE OILING

Crankcase Capacity — All engines hold 5 quarts. Add 1 quart with filter change.

Oil Filter — Replace at first oil change, then every second oil change after that.

Normal Oil Pressure — All engines. 55-60 psi at 2600 RPM.

Pressure Regulator Valve — In oil pump body. Not adjustable.

ENGINE OILING SYSTEM

See illustration. Force feed type with oil supplied under full pressure to all crankshaft, connecting rod, and camshaft bearings and to valve train parts. Spray from main and connecting rod bearings lubricates cylinder walls, piston pins and bushings. Timing chain and sprockets receive metered jet lubrication as do fuel pump eccentric and rocker arm. A hole in block from push rod gallery through distributor boss lubricates distributor shaft and bushings.

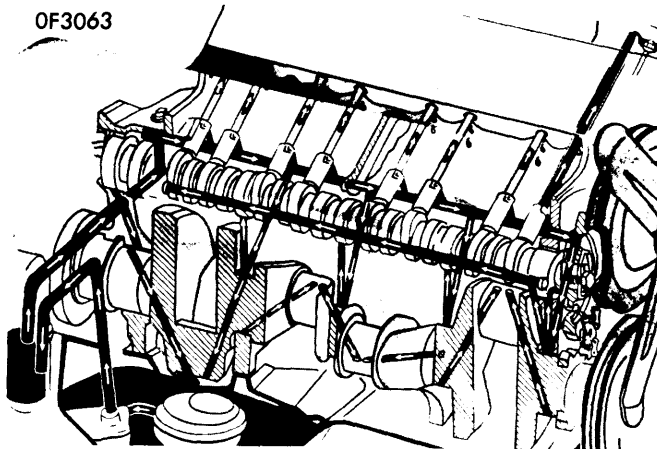

ENGINE OILING SYSTEM

Valve Lifters — Hydraulic lifters are fed individually by holes drilled in each lifter boss to main oil galleries in each bank.

Push Rods and Rocker Arms — Oil from each lifter is directed up through hollow push rods to rocker arms. Oil then passes through a hole in push rod contact area of rocker arm and fills it. This supply lubricates rocker arm ball and overflow lubricates top of valve stem and other valve train surfaces.

OIL PUMP

Removal — Remove oil pan splash baffle. Hold oil pump while removing attaching bolts. Lower oil pump carefully while removing pump drive shaft. **NOTE** — Removal and installation of pump does not affect engine timing. If pump is disassembled for cleaning and inspection, do not loosen or remove oil pump screen from pump body. Do not attempt to change oil pressure by varying length of pressure regulator spring.

Installation — Position drive shaft in distributor and oil pump drive gears. Use new gasket between pump and block. Index drive shaft with pump drive gear shaft and install attaching bolts.

OF3064

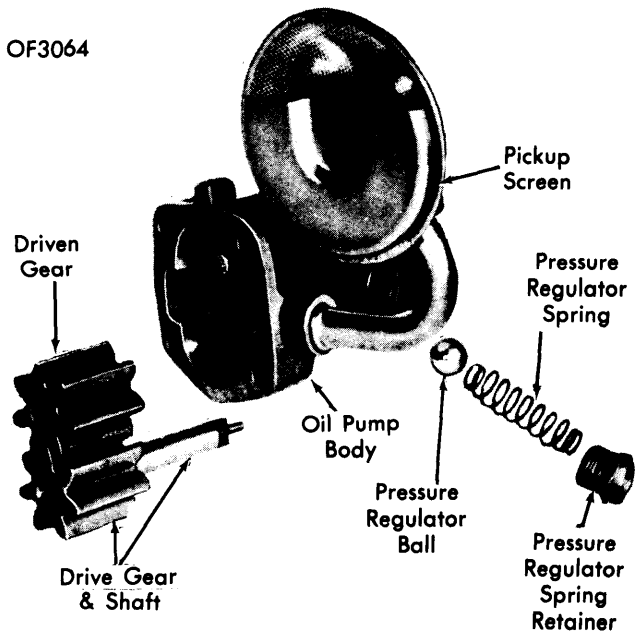

OIL PUMP ASSEMBLY

350", 400" & 455" PONTIAC, EXC. VENTURA (Cont.)

ENGINE OILING (Cont.)

TIGHTENING SPECIFICATIONS

Application	Ft. Lbs.
Cylinder Head	95
Intake Manifold	40
Exhaust Manifold	30
Oil Pan	12
Main Bearing Cap (Rear)	120
(All Others)	100
Con. Rod Caps (455" S.D.)	63
(All Others)	43
Flywheel	95
Vibration Damper	160
Camshaft Sprocket	40
Camshaft Thrust Plate	20
Engine Front Cover	12
Oil Pump-to-Block	30
Rocker Arm Stud	50
Rocker Arm Retaining Nut	20
Push Rod Chamber Cover	30-70 INCH Lbs.
Front Engine Mounts-to-Engine	70
Front Engine Mounts-to-Frame	50
Retainers-to-Transmission	30
Rear Engine Mounts	30