

CHRYSLER CORP. — 8 1/4" & 9 1/4" RING GEAR

Chrysler Corp., All Models

REMOVAL & INSTALLATION

NOTE — Some models use other units. See Chrysler Corp. 7 1/4" Ring Gear, or Sure Grip Differential in this section.

AXLE SHAFTS & BEARINGS

DESCRIPTION

Axle assembly is of the integral housing, hypoid gear type in which centerline of drive pinion is mounted below centerline of ring gear. A removable cover permits inspection and service of differential. Wheel bearings are straight roller type and roll directly on axle shaft. There is no external adjustment.

Removal — 1) Raise and support vehicle. Remove wheels and brake drums. Loosen housing cover screws to drain lubricant. Remove housing cover.

2) Turn differential case for access to lock screw. Remove lock screw and pinion shaft. Push axle shafts toward center of vehicle. Remove "C" locks from groove in axle shafts. Remove shafts from housing.

3) Do not damage roller bearing which remains in axle housing. Remove shaft seal from housing bore using button end of axle shaft. Dents caused by axle shaft splines should be polished smooth or rubber on outside diameter of seal will be torn and seal leakage will result.

4) To remove bearing, use suitable bearing separator tool (C-4167). If axle shaft and bearing are not damaged, then they may be reused. **DO NOT** reuse axle shaft seal after removal.

AXLE RATIO & IDENTIFICATION

Axle ratio identification number stamped on metal tag affixed to one of the cover screws. All 8 1/4" axles have a 10 bolt cover, 9 1/4" axles have a 12 bolt cover.

Axle Ratio Identification

Axle Ratio	No. of Teeth	
	Pinion Gear	Ring Gear
8 1/4" Ring Gear		
2.45-1	20	49
2.71-1	17	46
2.94-1	16	47
3.21-1	14	45
9 1/4" Ring Gear		
2.71-1	17	46
3.21-1	14	45

Installation — 1) Clean all parts thoroughly. Install axle shaft bearing. Make sure bearing is not cocked in bore. Bottom bearing against shoulder. Install axle shaft bearing seal and slide shaft into place. Install "C" washer lock in groove of axle shaft. Pull outward on shaft so that "C" lock seats in counter-bore of differential side gear.

2) Install differential pinion shaft through case and pinions. When installing pinion shaft, align hole in shaft with lock screw hole. Install lock screw and tighten. Install cover with suitable Silicone Rubber Sealant (Part No. 3683829) and tighten cover bolts. **NOTE** — Remember to reinstall axle ratio identification tag beneath one of the cover bolts.

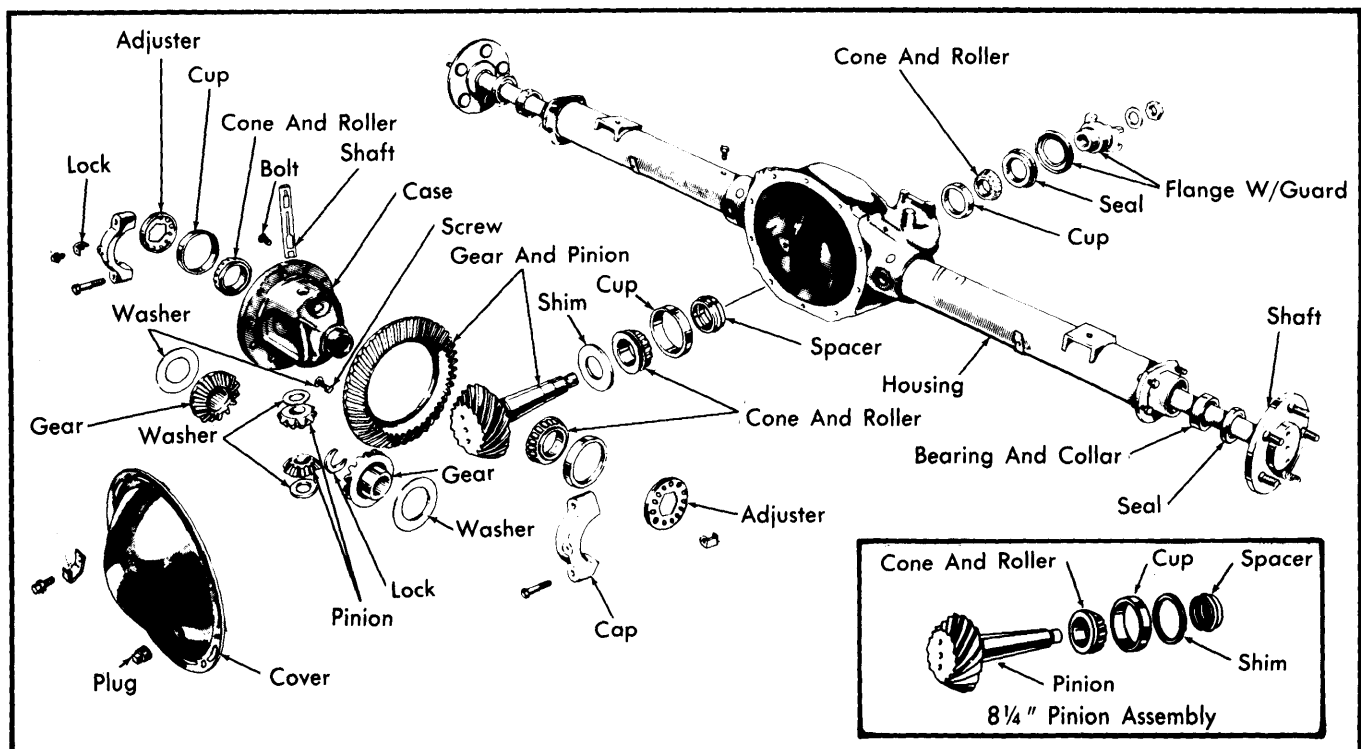

Fig. 1 Exploded View of Chrysler Corp. 8 1/4" and 9 1/4" Rear Axle Assembly

CHRYSLER CORP. — 8¼" & 9¼" RING GEAR (Cont.)

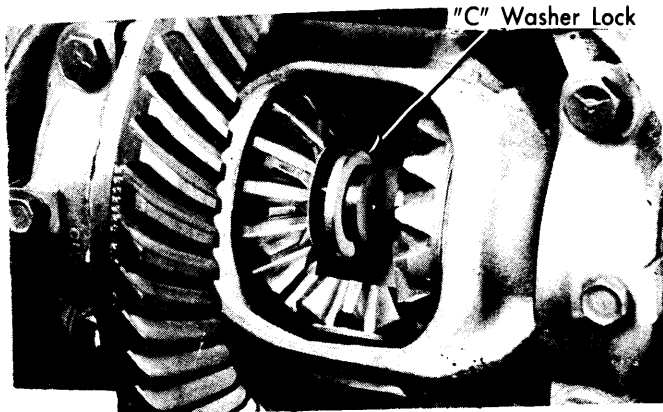

Fig. 2 Location of "C" Washer Lock

PINION FLANGE & OIL SEAL

1) Raise vehicle on hoist and make scribe marks on propeller shaft universal joint. Also mark pinion flange and end of pinion stem. Disconnect propeller shaft and secure in upright position.

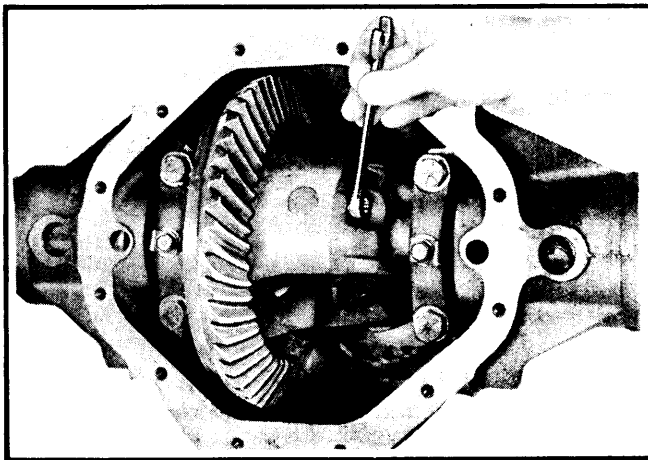

Fig. 3 Differential Pinion Shaft Lock Location

2) To prevent drag while measuring pinion bearing preload, remove wheels and any part of brake assembly which may cause drag. Measure pinion bearing preload by rotating pinion with an INCH pound torque wrench. Rotate pinion through several revolutions and record readings.

3) With suitable tool (C-3281), hold companion flange and remove drive pinion nut and Belleville washer. Remove flange with suitable tool (C-452 on 8¼" axles or DD-999 on 9¼" axles). Lower rear of vehicle to prevent lubricant leakage. Remove pinion oil seal.

4) Inspect flange for damage and repair as necessary. Install new pinion oil seal using suitable tool (C-4076 on 8¼" axles or C-3980 or C-4109 on 9¼" axles). Seal is properly installed when seal flange contacts housing flange face.

5) Position flange on pinion stem being careful to match scribe marks. Install Belleville washer (convex side of washer out) and nut. Tighten pinion nut to 210 ft. lbs.

6) Rotate pinion several revolutions to make sure bearing rollers are properly seated. Measure pinion bearing preload by using INCH pound torque wrench. Continue tightening pinion nut and checking preload until preload is at original setting.

7) Under no circumstances should preload be more than 10 INCH lbs. over original setting. **CAUTION** — Under no circumstances should pinion nut be backed off to lessen preload. If desired preload is exceeded, a new collapsible spacer must be installed and nut retightened until proper preload is obtained. In addition, universal joint flange must never be hammered, and no power tools should be used.

REAR AXLE HOUSING

Raise vehicle, then block brake pedal in UP position and remove wheels. Disconnect and cap brake lines to prevent loss of fluid. Disconnect parking brake cables. Mark propeller shaft universal joint and companion flange for relocation, then disconnect propeller shaft and secure in upright position. Remove shock absorbers and rear spring "U" bolts. Remove rear axle assembly. To install, reverse removal procedure.

OVERHAUL

1) Remove housing cover and drain lubricant into a container. Clean differential bearings, ring gear and pinion, and other internal surfaces. Blow dry with compressed air. Turn differential case to make differential pinion lock screw accessible and remove lock screw and pinion shaft. Remove "C" washer locks from recessed grooves in axle shafts, and remove axle shafts. Measure differential side play. There should be no side play.

2) Using a dial indicator mounted to housing, measure drive gear runout by turning drive gear several complete revolutions. Mark drive gear and differential case at point of maximum runout. Total indicator reading should not exceed .005".

3) Mark axle housing and bearing caps for proper relocation and remove adjuster lock from each bearing cap. Loosen, but do not remove bearing caps. Insert suitable tool (C-4164) through axle tube and loosen both hex adjusters. Very carefully remove bearing caps, adjuster and differential assembly. Use care not to mix bearing caps and cones and, on 8¼" axles, adjusters.

4) Using an INCH pound torque wrench, measure and record pinion bearing preload. Remove drive pinion nut, washer and flange. Remove and discard pinion oil seal. Remove pinion by driving rearward out of bearing. **NOTE** — Bearing rollers, cups and cones will be damaged during this process and must be replaced. Remove front and rear bearing cups from housing. On 8¼" axle there is a shim behind bearing cup, measure and record shim thickness. Discard shim.

5) Remove rear pinion bearing cone from pinion stem using suitable tools (C-293-P and C-293-42 on 8¼" axles, C-293-P and C-293-37 on 9¼" axles). Use care not to pull on bearing cage. Remove pinion shim and record thickness.

CHRYSLER CORP. - 8 1/4" & 9 1/4" RING GEAR (Cont.)

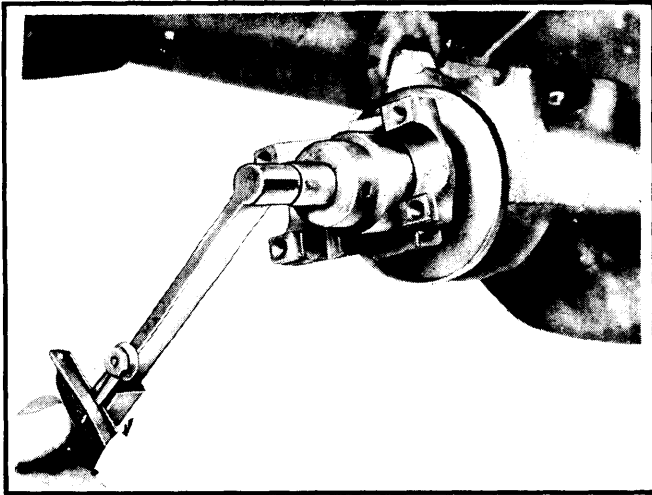

Fig. 4 Measuring Pinion Bearing Preload

Differential Case Reassembly - 1) Install thrust washers on side gears then position gears in counterbores of differential case. Position thrust washers on pinion gears then mesh with side gears, having pinion gears exactly 180° apart.

NOTE - Drive gear bolts are left hand thread. If drive gear runout did not exceed .005" prior to removal, case flange runout need not be remeasured.

2) Remove differential case assembly from carrier. Rotate side gears until differential pinions appear at case windows. Remove pinions, side gears and thrust washers. Using suitable puller, remove differential bearing cones.

Differential Case Disassembly - 1) Remove drive gear bolts. Using a brass drift, tap drive gear from differential case pilot. Install differential case into carrier housing, install pedestal caps and bolts and tighten. Using a dial indicator mounted to housing, check case for runout. Maximum runout should not exceed .003".

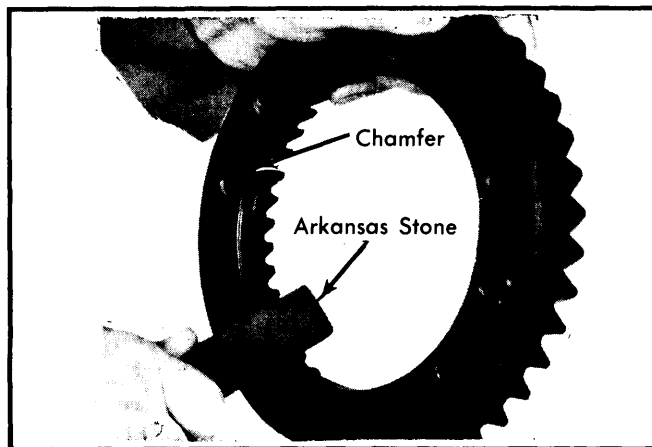

Fig. 5 Relieving Chamfer on Ring Gear Using a Cutting Stone

2) Rotate side gears to align pinion gears with differential pinion shaft holes in case. Install pinion shaft. Hole in pinion shaft must align with lock screw hole in differential case. **NOTE** - Do not damage thrust washers when installing pinion shaft.

3) Using suitable stone, relieve sharp edge of chamfer on inside diameter of ring gear. Heat ring gear in hot water or oil. Temperature should not exceed 300°F. **NOTE** - Do not use a torch. Using pilot studs to align gear to case, install new drive gear bolts through case flange and into drive gear. Place unit on soft-jawed vise and alternately tighten bolts.

4) Position each differential bearing cone on hub of differential case (taper away from drive gear) and install bearing cones using suitable tool. An arbor press may be used, however, never exert pressure against bearing cage.

Pinion Bearing Cup Installation - 1) Lubricate all parts before assembly. Start both drive pinion bearing cups and make sure they are not cocked.

2) On 8 1/4" axles, assemble pinion locating spacer (SP-6030) over body of main tool (SP-5385) followed by rear bearing cone. Position tool in rear axle housing, then install shaft locating sleeve (SP-5382), front pinion bearing cone, compression sleeve (SP-3194-B), centralizing washer (SP-534) and compression nut (SP-3193).

3) On 9 1/4" axles, assemble pinion locating spacer (SP-6017) over body of main tool (SP-526) followed by rear bearing cone. Position tool in rear axle housing, then install front pinion bearing cone, washer (SP-6022), compression sleeve (SP-535-A), centralizing washer (SP-534) and compression nut (SP-533).

4) Hold compression sleeve with holding tool (C-3281) and tighten nut. Allow tool to rotate as nut is being tightened in order not to damage bearing or cups. Leave tool in carrier for determining depth of mesh.

Pinion Setting (With Tool C-3715) - 1) With main tool left in axle housing after installing drive pinion bearing cups, loosen tool nut and retighten nut to 15-25 INCH lbs. of preload. Rotate after tightening to align bearing rollers. Install gauge block, SP-5383 for 8 1/4" or SP-6020 for 9 1/4", on main tool and tighten cap screw with Allen wrench.

2) Position crossbore arbor, SP-6029 for 8 1/4" or SP-6018 for 9 1/4", in axle housing differential bearing seat. Center arbor so that equal distance is maintained at both ends. Position bearing caps and attaching bolts on carrier pedestals and insert a piece of .002" shim stock between arbor and each cap. Tighten cap bolts to 10 ft. lbs.

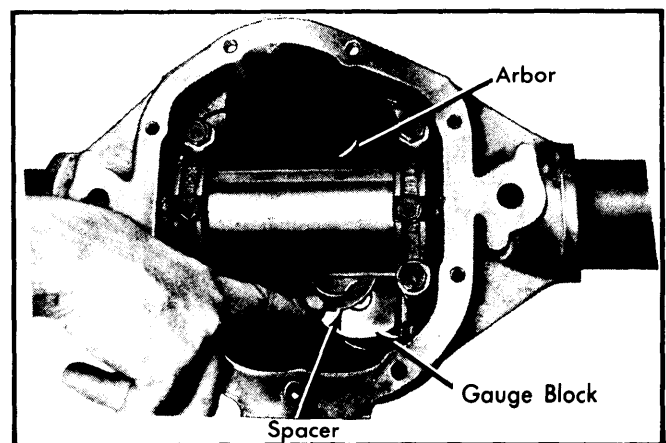

Fig. 6 Measuring Housing for Pinion Shim Thickness

CHRYSLER CORP. — 8 1/4" & 9 1/4" RING GEAR (Cont.)

3) Select rear pinion bearing mounting shim which will fit between crossbore arbor and gauge block. This fit must be snug but not tight.

4) To select shim pack for installation, read markings on end of pinion head. When marking is minus (-), add that amount to thickness of shim pack. When marking is plus (+), subtract that amount. Shims are available in increments of .001" from .020" to .038".

Pinion Installation & Bearing Preload — 1) On 8 1/4" axles, use hammer and soft punch and remove rear bearing cup from housing. Place selected shim in axle housing rear pinion cup bore and install rear bearing cup. Lubricate rear pinion bearing cone and install on pinion stem using suitable tool (DD-955). On 9 1/4" axles, place selected shim on pinion stem followed by rear pinion bearing cone. Using tool C-3095 (or equivalent), press bearing on pinion stem. On both axles, an arbor press may be used with installation tools.

2) Insert drive pinion and bearing assembly up through axle housing. Install a new collapsible spacer followed by front pinion bearing cone on pinion stem. Install companion flange.

CAUTION — Use care not to collapse the spacer.

3) Install drive pinion oil seal until seal flange contacts housing flange face. Outside diameter of seal is precoated with a special sealer so no sealing compound is required.

4) With pinion supported in axle assembly, install companion flange on pinion stem, followed by Belleville washer and nut. Using suitable tool, (C-3718 for 8 1/4" axles) or (DD-999 for 9 1/4" axles), and holding tool C-3281 (or equivalent), draw flange into position. Hold universal joint flange with holding tool and retighten pinion nut to remove end play in pinion, while rotating the pinion to insure proper bearing roller seating.

5) Tighten pinion nut to 210 ft. lbs. and measure pinion bearing preload by rotating pinion with an INCH lb. torque wrench. The correct bearing preload specifications are 20-35 INCH lbs. for new bearings. With original rear pinion bearing and new front bearing, 10 INCH lbs. more than recorded before teardown. If correct preload cannot be obtained at 210 ft. lbs., tighten in small increments until proper preload is obtained.

NOTE — DO NOT back off nut to lessen preload. If desired preload is exceeded, a new collapsible spacer must be installed and nut retightened until proper preload is obtained.

Differential Bearing Preload & Ring & Pinion Backlash Adjustment — 1) Set pinion bearing preload in normal manner then install differential assembly with bearing caps and adjusters. Differential bearings and adjuster threads must be liberally lubricated with axle oil.

2) Check alignment of adjuster threads then tighten top cap screws on right and left sides to 10 ft. lbs. Tighten bottom cap screws finger tight until head is just seated on bearing cap. Using Tool C-4164 (or equivalent), check each adjuster to make sure that it rotates freely, then turn both adjusters in until bearing freeplay is eliminated with some drive gear backlash (approximately .010"), existing between drive gear and pinion.

3) Seat bearing rollers. **NOTE** — To assure accurate adjustment changes and to maintain gear mesh index, bearings must be seated by turning drive pinion one half turn in each direction five to ten times, each time adjuster is moved.

4) Install dial indicator and find point of minimum backlash checking at four positions approximately 90° intervals around drive gear. Rotate gear to position with least backlash and mark index so that all backlash readings will be taken with same teeth mesh. **NOTE** — Permissible backlash variation is .003".

5) Loosen right adjuster and tighten left adjuster until backlash is .003-.004", with each adjuster tightened to 10 ft. lbs. Seat roller bearing, then tighten bearing cap screws to 100 ft. lbs.

6) Tighten right adjuster to 70 ft. lbs. on 8 1/4" axles, 75 ft. lbs. on 9 1/4" axles, and seat rollers at same time until torque remains constant at 70 ft. lbs. for 8 1/4" or 75 ft. lbs. for 9 1/4".

NOTE — Maintain specified adjuster torque to obtain accurate backlash and preload setting. Backlash should be .006-.008". If backlash does not meet specifications, increase torque on right adjuster and seat rollers until correct backlash is obtained.

7) Tighten left adjuster to 70 ft. lbs. on 8 1/4" axles or 75 ft. lbs. on 9 1/4" axles and seat bearings at same time until torque remains constant.

8) Install adjuster locks and torque lock screws to 90 INCH lbs.

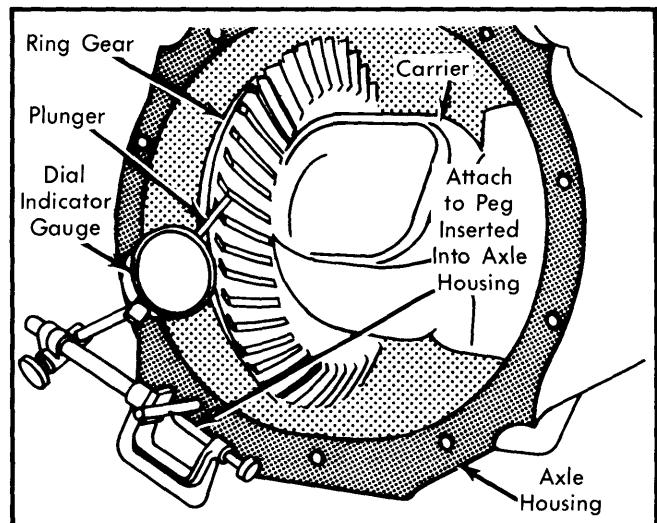

Fig. 7 Measuring Ring and Pinion Backlash

TIGHTENING SPECIFICATIONS

Application	Ft. Lbs.
Differential Bearing Cap Bolts	100
Ring Gear-to-Case Bolts	①55
Pinion Flange Nut	210(Min.)
Carrier Cover Bolts	250 INCH lbs.
Brake Support Plate Retainer Nuts	35
Propeller Shaft Bolts	170-200 INCH lbs.
"U" Bolt Nuts	45
Wheel Stud Nuts	85
Shock Absorber Nuts	50

① — 70 ft. lbs. on 9 1/4" axle