

## 265" & 301" V8

### IDENTIFICATION CODING

#### ENGINE IDENTIFICATION

The fifth digit of the Vehicle Identification Number identifies the engine size. In addition, an engine code number is stamped on a machined pad on right front side of engine.

Application	VIN Code
265" (4.3L) 2-Bbl. ....	S
301" (4.9L) 4-Bbl. ....	W
301" (4.9L) 4-Bbl. Turbocharged .....	T

#### ENGINE REMOVAL

See Engine Removal at end of ENGINE Section.

### CYLINDER HEAD & MANIFOLDS

#### INTAKE MANIFOLD

**Removal** — Drain cooling system. Remove air cleaner and disconnect closed ventilation pipe at air cleaner. Disconnect air cleaner vacuum source at manifold and hot air duct. Remove water outlet bolts and set outlet aside with radiator hose attached. Disconnect wiring, vacuum hoses, fuel lines, and carburetor linkage. Remove carburetor and intake manifold as a unit.

**Installation** — Install new gaskets on cylinder heads and intake manifold assembly. Install "O" ring seal between manifold and timing chain cover. Install intake manifold assembly on engine and tighten bolts loosely. Tighten intake manifold to timing cover chain bolt. Tighten other bolts to specification.

#### CYLINDER HEAD

**Removal** — Drain cooling system. Remove air cleaner and carburetor heated air pipe. Remove intake manifold, push rod cover and rocker arm cover. Remove push rods, battery ground cable and engine ground strap. Remove exhaust pipe-to-manifold bolts. Remove cylinder head bolts and remove head with exhaust manifold attached.

**CAUTION** — Do not strike rocker arm studs. Studs are hardened and may crack if struck.

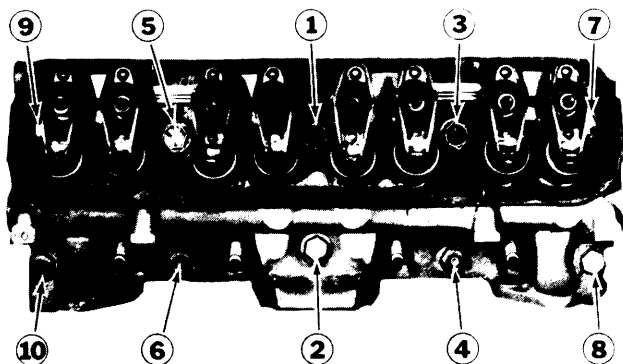

Fig. 1 Cylinder Head Tightening Sequence

**Installation** — 1) Clean all gasket surfaces. Place new gasket on block; install cylinder head. Start all bolts and tighten to specifications. See Fig. 1.

2) Install push rods, reposition rocker arms and tighten to specifications. To complete installation, reverse removal procedure.

**NOTE** — If rocker arm studs have been removed from head, sealer must be applied to lower threads of stud.

### VALVES

#### VALVE ARRANGEMENT

E-I-I-E-E-I-I-E (both banks, front to rear).

#### VALVE GUIDE SERVICING

Valve guides are integral with head. If valve stem to guide clearance is excessive, ream guide to proper size to accommodate oversize valve stems. Valves are available in .003" oversize. Valve seat must be refaced after reaming valve guide.

#### VALVE STEM OIL SEALS

Valve stem seals are installed in the 2nd groove (from end of stem). Special valve seal installer and tester tools are available.

#### VALVE SPRINGS

**Removal** — 1) Remove rocker arm cover, spark plug, and distributor cap. Crank engine until distributor rotor is in position to fire on cylinder being serviced. Install air fitting tool (J-22794) in spark plug hole.

2) Apply air pressure to cylinder. Remove rocker arm. Thread valve spring compressor stud (J-8929) on rocker arm stud and compress valve spring, using compressor and nut. Remove valve spring retainer cup locks and then remove valve spring compressor, valve spring retainer cup shield and valve stem seal.

**Installation** — Install new parts and compress valve spring. Install seal and locks. Remove compressor. Install rocker arm and tighten rocker arm ball retaining nut.

#### ROCKER ARM STUDS

**Removal & Installation** — 1) Drain radiator. Remove rocker arm cover. Remove rocker arm and nut. Using a deep well socket, remove rocker arm stud.

**NOTE** — Coat lower stud threads with thread sealer.

2) Install new stud and tighten to specifications.

#### HYDRAULIC VALVE LIFTER ASSEMBLIES

**NOTE** — Lifters are serviced as complete assemblies only. Parts are not interchangeable between lifters. If any component of lifter is worn or damaged, complete lifter must be replaced.

## 265" &amp; 301" V8 (Cont.)

If lifters are disassembled for cleaning and inspection, after reassembly they should be tested using a suitable leak-down tester. Leak-down rate should be 20-90 seconds with 50 pound load and plunger travel of .125". Replace lifters if not within specified limits.

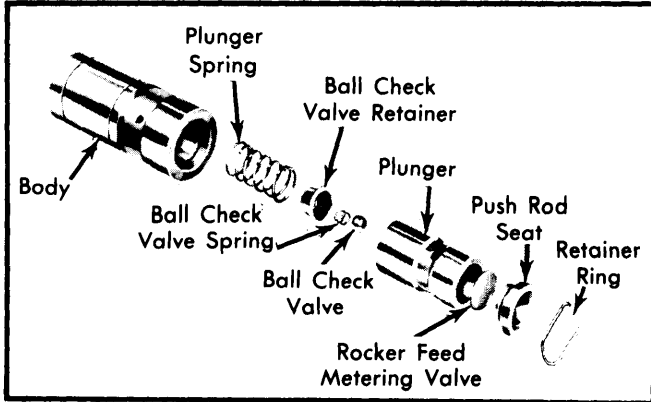

Fig. 2 Hydraulic Valve Lifter Assembly

## PISTONS, PINS &amp; RINGS

## OIL PAN

See oil pan removal at end of ENGINE Section.

## PISTON &amp; ROD ASSEMBLY

**Removal** – 1) Remove oil pan, oil pump, intake manifold and cylinder head(s). Use ridge reamer to remove any ridge or deposits on upper end of cylinder bore.

**NOTE** – Piston must be at bottom of stroke and covered with cloth to collect cuttings.

2) Inspect connecting rods and caps for cylinder identification and mark as necessary. Remove rod cap and push rubber hose onto connecting rod bolts (to protect cylinder walls). Push piston and rod assembly out top of cylinder block. Install cap on mating rod.

**Installation** – When installing piston rings, make sure markings on compression rings face up (top of piston). Lightly coat pistons, rings and cylinder bores with motor oil. Compress piston rings using suitable ring compressor. Install piston and rod assembly in cylinder bore, making sure notch in top of piston faces front of engine. See Fig. 3. Lubricate bearing, install rod cap and tighten nuts.

## FITTING PISTONS

Fit piston by measuring inside diameter of cylinder bore and outside diameter of piston. Clearance is .0025-.0033".

**NOTE** – Measure piston and bore at room temperature. Higher or lower temperatures will result in improper fit.

## PISTON PINS

**Removal** – Using suitable removal tool, press piston pin out of piston and rod assembly. Separate piston from rod.

**Installation** – 1) If piston pin fit is not to specifications, pin bores must be honed and oversize pins installed. When assembling piston and connecting rod, notch in top of piston must face front of engine.

2) Dimpled side of connecting rod must face rearward on both banks. Lubricate piston pin and install using a suitable tool and press.

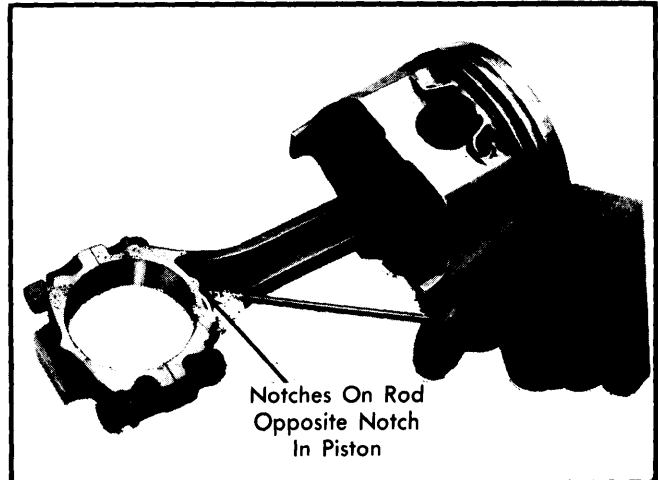

Fig. 3 Connecting Rod Thrust Side Identification

## CRANKSHAFT &amp; ROD BEARINGS

## MAIN AND CONNECTING ROD BEARINGS

**NOTE** – Following procedures are performed with oil pan, oil baffle and oil pump removed.

**Connecting Rod Bearings** – After ensuring rod caps are marked for cylinder identification, remove rod caps (with crankshaft journal of cylinder to be checked at bottom of throw). Use Plastigage method to check for proper bearing clearances. New bearings are available in standard, .001" and .002" undersize. Selective fitting is required on each connecting rod. A standard bearing half may be used in combination with a .001" undersize or a .002" undersize in combination with a .001" undersize. Coat bearing surfaces with oil, install rod cap and tighten nuts. Rotate crankshaft after bearing replacement to ensure that bearings are not tight.

**Main Bearing** – 1) When checking main bearing clearance with engine in vehicle, place a .002" brass shim between crankshaft journal and lower bearing in each bearing cap next to bearing being checked. Ensure that all cap bolts are tight and remove bearing cap of bearing to be checked. Use Plastigage method to check clearances. New bearings are available in standard, .001" and .002" undersize.

2) Remove upper main bearing by inserting suitable tool in oil hole of crankshaft journal and rotating crankshaft clockwise to roll bearing from engine. Oil new upper bearing and insert plain end of bearing at indented side of bearing seal and rotate crankshaft to install. Install lower bearing in cap so indentation in bearing and cap coincide. Install bearing cap and tighten bolts.

3) During production some main bearing journals may have been ground .009" undersize. Engines assembled with these crankshafts will be identified by a "9" stamped on undersize

## 265" & 301" V8 (Cont.)

journal along with a spot of light green paint. Main bearing caps will be painted light green on each side of affected journals.

### THRUST BEARING

With all main caps and connecting rods installed and torqued, tap end of crankshaft at rear until tight against front of thrust bearing. Measure clearance between crankshaft counterweight and thrust bearing. If clearance is outside limits, (.003" to .009"), install new thrust bearing.

### REAR MAIN BEARING OIL SEAL

1) Remove oil pan and oil pump. Remove rear main bearing cap and use suitable tool made from brass bar stock to pack upper seal. See Fig. 4. Insert tool against one end of oil seal in block and drive seal gently into groove until tool bottoms. Remove tool and repeat at other end of seal in cylinder block. Clean block and bearing cap parting line thoroughly.

2) Form a new seal in cap using suitable tool (J-7588). Remove new seal and cut four pieces approximately  $\frac{3}{8}$ " long from this seal. Work two  $\frac{3}{8}$ " pieces into each gap which has been made at end of seal in block. Without cutting ends, work seal pieces in until flush with parting line and no fibers are protruding over metal next to groove.

3) Form another new seal in cap using suitable tool (J-7588). Assemble cap to block and tighten. Remove cap and inspect parting line to insure that no seal material has been compressed between block and cap. Clean as necessary. Apply a  $\frac{1}{16}$ " bead of sealer from center of seal to outer gasket groove. Reassemble cap and tighten.

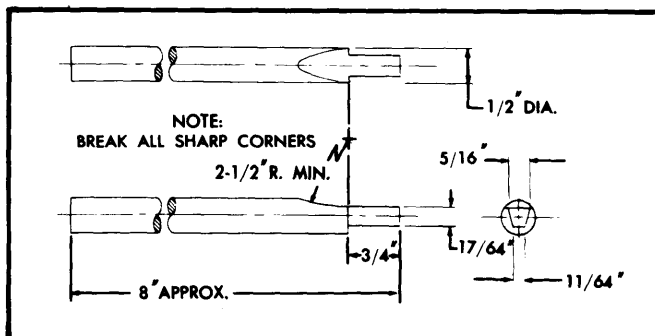

Fig. 4 Upper Rear Main Bearing Oil Seal Installation Tool

### CAMSHAFT

#### ENGINE FRONT COVER

**Removal** — Drain radiator and cylinder block. Remove fan belt and drive belt(s). Remove fan and pulley. Disconnect lower radiator hose. Remove fuel pump and harmonic balancer. Remove bolts attaching oil pan to cover, cover to block, and cover to intake manifold. Remove cover.

**Installation** — Thoroughly clean gasket surfaces on block and cover, inspect oil pan gasket and replace if damaged. Use new "O" ring seal in water passage in intake manifold. Install and tighten cover-to-block and intake manifold bolts first, then install oil pan screws.

#### FRONT COVER OIL SEAL

To replace seal, remove fan and accessory drive belts. Remove harmonic balancer. Remove seal by prying out of bore with pry bar. Using a suitable tool (J-21147), install new seal with lip of seal facing rear of engine.

#### TIMING CHAIN

**Removal** — Remove timing chain cover, fuel pump eccentric and bushing. Remove timing chain cover oil seal. Align timing chain marks to simplify reassembly. See Fig. 5. Slide timing chain and sprockets off crankshaft and camshaft at the same time.

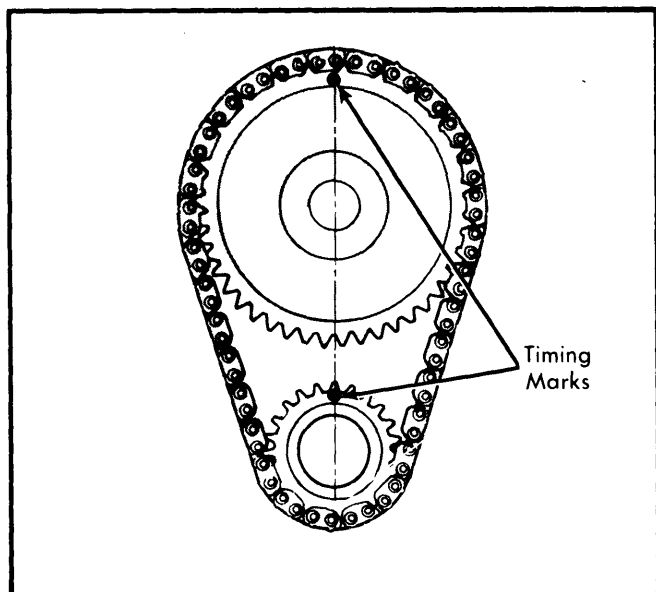

Fig. 5 Timing Chain Sprocket Alignment

**Installation** — Install new timing chain and/or sprockets, ensuring that marks on timing sprockets are aligned exactly on a straight line passing through shaft centers. Camshaft should extend through sprocket so hole in fuel pump eccentric will locate on shaft.

#### CAMSHAFT

**NOTE** — Camshaft may be removed without removing engine from vehicle. It may be necessary to raise front of engine to permit removal of camshaft.

**Removal** — 1) Remove transmission and flywheel. Drain cooling system. Remove hood latch brace and radiator. Remove rocker arm covers, distributor, intake manifold, push rod cover, push rods and lifters.

2) Remove harmonic balancer, fuel pump, timing chain cover, fuel pump eccentric and bushing. Align timing marks on timing chain sprockets and remove timing chain and sprockets. Remove camshaft thrust plate and carefully pull camshaft from engine.

**Installation** — To install, reverse removal procedures.

**NOTE** — Before installation, coat camshaft lobes and inner diameters of bearings with heavy oil. Rotate camshaft several revolutions to ensure that it is free.

## 265" & 301" V8 (Cont.)

### CAMSHAFT BEARING REPLACEMENT

Use suitable tool (J-6173-01) and note the following:

- 1) To replace rear bearing (without removing and disassembling engine) propeller shaft, transmission and clutch housing must be removed to get at camshaft rear plug. If front bearing is being replaced, insert remover adapter in center bearing to support shaft.
- 2) Outside of new bearing should be coated with oil before installation. Notch in edge of bearing is used to properly position bearing with respect to oil holes when installing. Index notch in edge of bearing with pin on replacer adapter. When bearings are installed in production, notches all face front except on rear bearing. In field service, all bearings should be installed with notches facing rear.
- 3) Rear bearing should be pulled in until front edge is flush with block to leave room for camshaft rear plug. Other bearings should be flush with both sides of bearing web.

### ENGINE OILING

**Crankcase Capacities** – 4 quarts with or without oil filter change.

**Oil Filter** – Replace at first oil change, then every second oil change after that.

**Normal Oil Pressure** – 38-42 psi @2600 RPM.

**Pressure Regulator Valve** – In oil pump body. Not adjustable.

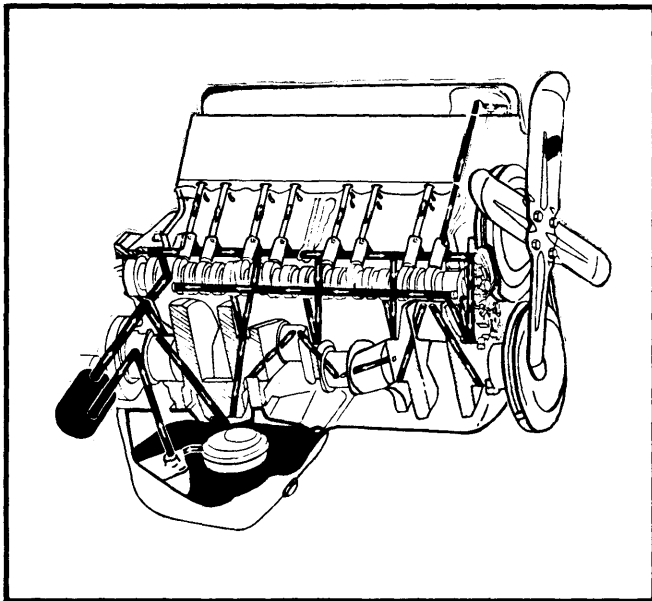

**Fig. 6 Engine Oiling System**

### ENGINE OILING SYSTEM

See Fig. 6. Force feed type with oil supplied under full pressure to all crankshaft, connecting rod, and camshaft bearings and to valve train parts. Splash from crankshaft and connecting rod lubricate cylinder walls, piston pins and bushings. Timing chain and sprockets receive metered jet lubrication as do fuel pump eccentric and rocker arm. A hole in the block from the push rod gallery through distributor boss lubricates distributor shaft and bushings.

**Push Rods and Rocker Arms** – Oil from each lifter is directed up through hollow push rods to rocker arms. Oil then passes through a hole in push rod contact area of rocker arm and fills it. This supply lubricates rocker arm ball and overflow lubricates top of valve stem and other valve train surfaces.

### OIL PUMP

**Removal** – 1) Remove oil pan splash baffle. Hold oil pump while removing attaching bolts. Lower oil pump carefully while removing pump drive shaft.

**NOTE** – Removal and installation of pump does not affect engine timing.

2) If pump is disassembled for cleaning and inspection, do not loosen or remove oil pump screen from pump body. Do not attempt to change oil pressure by varying length of pressure regulator spring.

**Installation** – Position drive shaft in distributor and oil pump drive gears. Use new gasket between pump and block. Index drive shaft with pump drive gear shaft and install attaching bolts.

### TIGHTENING SPECIFICATIONS

Application	Ft. Lbs.
Cylinder Head Bolts .....	95
Intake Manifold Bolts .....	40
Exhaust Manifold Bolts .....	35
Oil Pan Bolts .....	12
Main Bearing Cap Bolts .....	70
Rear Main Bearing Cap Bolts .....	100
Connecting Rod Bearing Cap Bolts .....	35
Flywheel .....	95
Harmonic Balancer .....	160
Camshaft Sprocket .....	40
Engine Front Cover .....	30
Oil Pump .....	30
Rocker Arm Stud .....	50
Rocker Arm Stud Nut .....	20

# General Motors V8 Engines

6-105

## 265" & 301" V8 (Cont.)

### ENGINE SPECIFICATIONS

GENERAL SPECIFICATIONS						
Engine	Net HP at RPM	Torque (Ft. Lbs. at RPM)	Compr. Ratio	Bore	Stroke	Displ. Cu. Ins.
265" 2-Bbl.	120@3600	210@1600	8.3:1	375"	3.00"	265
301" 4-Bbl.	150@4000	240@2000	8.1:1	4.00"	3.00"	301
301" 4-Bbl. Turbocharged	185@4000	280@2000	7.6:1	4.00"	3.00"	301

VALVES							
Engine & Valve	Head Diam.	Face Angle	Seat Angle	Seat Width	Stem Diameter	Stem Clearance	Valve Lift
265" Int.	1.72"	45°	46°	....	.3418-.3425"	.0010-.0027"	.364"
265" Exh.	1.50"	45°	46°	....	.3418-.3425"	.0010-.0027"	.364"
301" Int.	1.72"	45°	46°	.....	.3418-.3425"	.0010-.0027"	.350"
301" Exh.	1.50"	45°	46°	.....	.3418-.3425"	.0010-.0027"	.350"

PISTONS, PINS, RINGS						
Engine	PISTONS		PINS		RINGS	
	Clearance	Piston Fit	Rod Fit	Rings	End Gap	Side Clearance
265"	⓪.0025-.0033"	.0002-.0004"	Press	1	.010-.020"	.0015-.0035"
301"	⓪.0025-.0033"	.0002-.0004"	Press	2	.010-.020"	.0015-.0035"
				3	.035"	.0015-.0035"

⓪ — Measurement taken at top of skirt.

CRANKSHAFT MAIN & CONNECTING ROD BEARINGS							
Engine	MAIN BEARINGS				CONNECTING ROD BEARINGS		
	Journal Diam.	Clearance	Thrust Bearing	Crankshaft End Play	Journal Diam.	Clearance	Side Play
265"	3.00"	.0004-.0020"	No. 4	.006-.022"	2.25"	.0005-.0025"	⓪.006-.022"
301"	3.00"	.0004-.0020"	No. 4	.006-.022"	2.25"	.0005-.0025"	⓪.006-.022"

⓪ — Total of both rods.

CAMSHAFT			
Engine	Journal Diam.	Clearance	Lobe Lift
All	⓪1.900"	....	....

⓪ — Bearing Diameter.

VALVE SPRINGS			
Engine	Free Length	PRESSURE (LBS.)	
		Valve Closed	Valve Open
265"	⓪1.69"	75@1.66"	175@1.29"
301"	⓪1.69"	75@1.66"	175@1.29"

⓪ — Installed height.