

MOTORCRAFT POSITIVE ENGAGEMENT STARTER

Ford
Jeep

DESCRIPTION

Unit is a four pole, four brush starter with three series of coils and one shunt coil. Shunt coil is wound around a moveable pole piece which operates the integral positive engagement drive mechanism.

PERFORMANCE TESTS

STARTER CRANKING CIRCUIT

Make test connections as shown in illustration. Crank engine with ignition off by disconnecting and grounding high tension lead from coil, and connecting jumper from battery terminal of starter relay to "S" terminal of relay. Maximum allowable voltage drop should be as follows:

- 1) With voltmeter negative lead connected to starter terminal and positive lead connected to battery positive terminal (connection 1 in illustration), voltage drop should not exceed .5 volt.
- 2) With voltmeter negative lead connected to battery terminal of starter relay and positive lead connected to battery positive terminal (connection 2), voltage drop should not exceed .1 volt.
- 3) With voltmeter negative lead connected to starter terminal of starter relay and positive lead connected to battery positive terminal (connection 3), voltage drop should not exceed .3 volt.
- 4) With voltmeter negative lead connected to negative terminal of battery and positive lead connected to engine ground (connection 4), voltage drop should not exceed .1 volt.

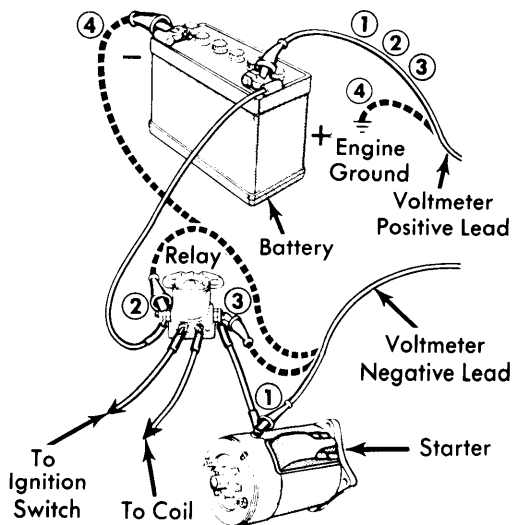

5FO01

STARTER CRANKING CIRCUIT TEST

STARTER LOAD TEST

Make test connections as shown in illustration. **CAUTION** — Make sure no current is flowing through ammeter and position rheostat at maximum counterclockwise position. Crank engine with ignition off by disconnecting and grounding high tension lead from coil, and connecting jumper from battery terminal of starter relay to "S" terminal of relay. Note voltmeter reading. Stop cranking engine, reduce resistance of carbon pile until voltmeter indicates same reading as when cranking. Ammeter now indicates current draw under load.

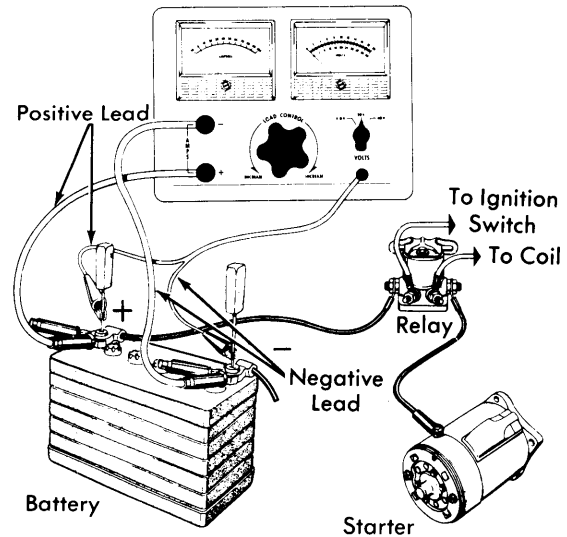

5FO02

STARTER LOAD TEST

STARTER NO-LOAD TEST

Make test connections as shown in illustration. **CAUTION** — Make sure no current is flowing through ammeter and position

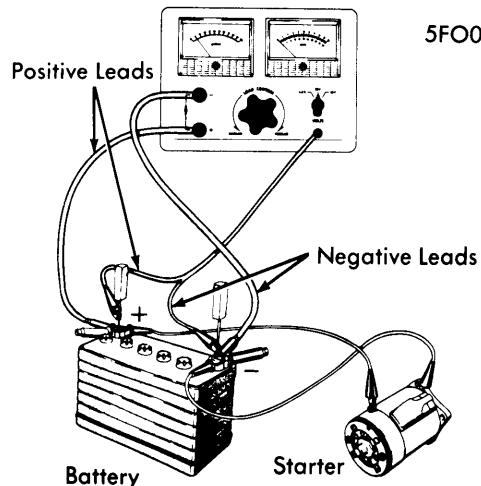

5FO03

STARTER NO-LOAD TEST

MOTORCRAFT POSITIVE ENGAGEMENT STARTER (Cont.)

rheostat at maximum counterclockwise position. Note voltmeter reading. Disconnect starter from battery and reduce resistance of rheostat until voltmeter indicates same reading as when starter was running. Ammeter will indicate starter no-load current draw.

OVERHAUL

DISASSEMBLY

- 1) Remove brush cover band and starter drive lever cover. Remove brushes from brush holders and note lead positions for reassembly. Remove through bolts, starter drive end housing and starter drive plunger lever return spring. Remove actuating lever pivot pin. Remove lever and slide armature out.
- 2) Remove stop ring retainer. Remove and discard stop ring retaining starter drive gear to end of armature shaft, then remove starter drive gear assembly. Remove brush end plate. Remove screws retaining ground brushes to frame. Bend tab up on field coil, which operates drive gear actuating lever, retaining sleeve. Remove sleeve.
- 3) Remove coil retaining screws. Unsolder field coil leads from terminal screw, remove pole shoes and coils from frame. Unsolder insulated brush leads from field coils. Remove starter terminal nut, washer, insulator, and terminal from starter frame.

CLEANING

Use a brush or air hose to clean field coils, armature, commutator, armature shaft, front end plate, and rear end housing. Wash all other parts in solvent and dry with air.

PARTS REPLACEMENT & TESTING

Brushes & Springs — Check brush holders for broken springs and insulated brush holders for shorts to ground. Tighten any loose rivets. Replace brushes if worn to $\frac{1}{4}$ " in length. Measure spring tension with spring scale hooked under spring near end, pull on line parallel to edge of brush and note the reading just as spring end leaves brush. Spring tension should be 40 ozs. If replacing brushes, use a 300 watt soldering iron and rosin core solder.

Armature — Check armature for shorted coils with a growler. Test for grounded coils using a test light, or a voltmeter and battery connected in series by touching one test probe to commutator and other test probe to core or armature shaft. If test light glows, or voltmeter shows any reading, coils are grounded. Inspect armature shaft and two bearings for scoring or excessive wear. Inspect armature windings for broken or burned insulation and unsoldered connections. If commutator is rough or more than .005" out of round, reface in a lathe removing only enough material to provide a smooth, even surface.

Field Coil Assembly — Inspect the field coils for burned or broken insulation and continuity. Check field brush connections and lead insulation. To check for grounded field windings, connect a voltmeter as shown in illustration. If voltmeter indicates any voltage, field windings are grounded. **NOTE** — Both field brushes and holding coil ground lead must be kept away from frame during this test and holding coil ground lead disconnected.

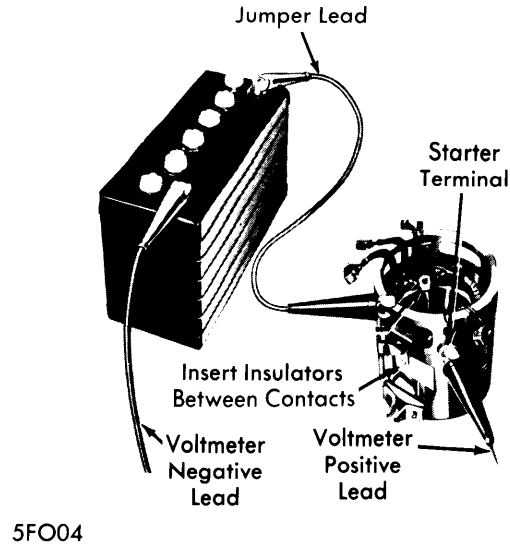

GROUNDING FIELD WINDINGS CIRCUIT TEST

REASSEMBLY

- 1) Install starter terminal, insulator, washers, and retaining nut. **NOTE** — Position slot in screw perpendicular to frame end surface. Position coils and pole pieces with coil leads in terminal screw slot, then install retaining screws. As screws are tightened, strike frame several sharp blows with soft-faced hammer to seat and align pole shoes, then stake screws.
- 2) Install solenoid coil and retainer, bend tabs to retain coils on frame. Solder field coils and solenoid wire to starter terminal using rosin core solder. Check for continuity and grounds in assembled coils. Position new insulated brush leads on field coil terminal while using clip provided with brushes to hold brush leads to terminal. Solder lead, clip, and terminal with rosin core solder.
- 3) Position solenoid coil ground terminal on nearest ground screw hole, position both ground brushes and install attaching screws. Position commutator end plate on frame with end plate boss in frame slot. Apply thin coating of lubricant on armature shaft splines, install drive assembly on shaft, then install new stop ring and retainer. Position fiber thrust washer on commutator end of armature and position armature in starter frame.
- 4) Position starter drive gear plunger lever to frame and starter drive assembly, install pivot pin. Partially fill drive end housing bearing bore with grease (approximately $\frac{1}{4}$ full).

MOTORCRAFT POSITIVE ENGAGEMENT STARTER (Cont.)

Position drive plunger lever return spring and drive end housing to frame, install and tighten through bolts to 55-75 INCH lbs. **CAUTION** — Do not pinch brush leads between plate and frame. Make sure stop ring retainer is seated properly in drive housing.

5) Install brushes in brush holders, centering springs on brushes. Position drive gear plunger lever cover on starter and install brush cover band with a gasket. Tighten band retaining screw. Check starter no-load current draw.

POSITIVE ENGAGEMENT SPECIFICATIONS				
Dia. (Inches)	Normal Draw (Amps)	Normal Speed (RPM)	Max. Load (Amps)	No Load (Amps)
4	150-200	180-250	460	70
4 1/4	150-180	150-290	670	70

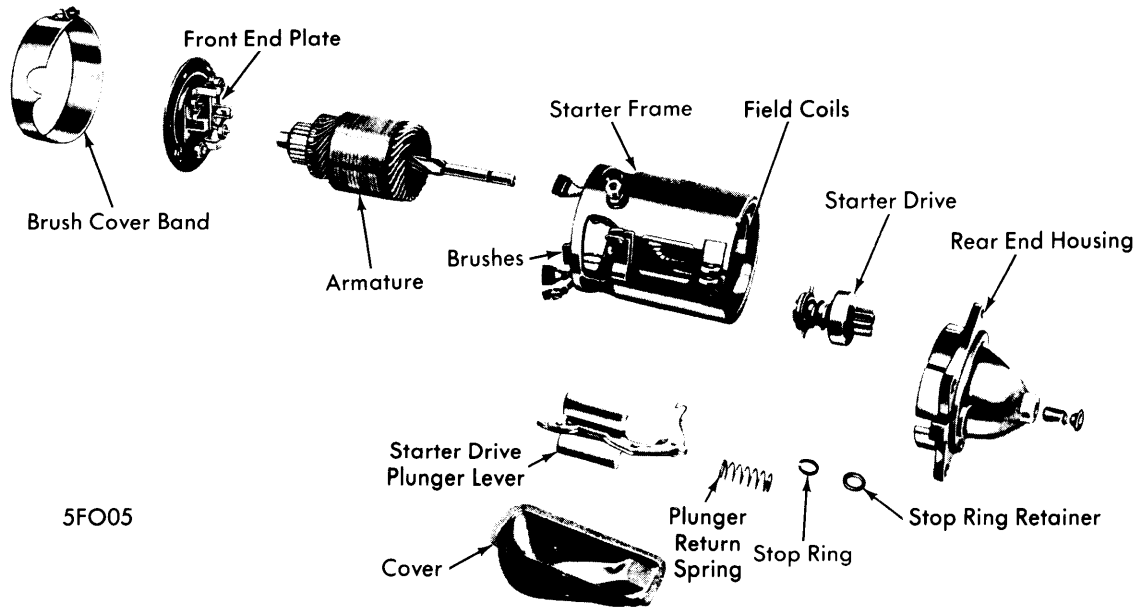

POSITIVE ENGAGEMENT STARTER ASSEMBLY