

CHRYSLER CORP.

Dodge
Plymouth

DESCRIPTION

Two-speed wiper motors have permanent magnetic fields and are controlled by feeding power to different brushes for low and high speed. For low speed operation, current flows through torque limiting resistor and then to low speed brush. For high speed operation, current is fed directly to high speed brush. Motor speed is selected by rotating switch knob. A circuit breaker protecting wiper system is integral with wiper switch.

TROUBLE SHOOTING

Wiper Inoperative — Binding linkage. Faulty wiper switch. Open or grounded wiring. Faulty motor.

Motor Draws Excessive Current (Circuit Breaker May Cycle) — Shorted motor or park switch. Jammed gearbox mechanism. Shorted or burned armature. Defective bearings. Broken brush holder.

Motor Runs One Speed Only — Open circuit in red or brown wiring. Defective wiper switch. Low speed torque limiting resistor open.

Motor Runs But Output Crank Does Not Turn — Stripped intermediate gear or output gear. Output gear slips on output shaft. Crank arm not fastened properly to output gear shaft.

Blades Will Not Park — Motor park switch open. Faulty instrument panel switch. Arm set at incorrect position.

Motor Does Not Shut Off — Defective armature brake switch. Broken brush holder. Faulty park mechanism.

TESTING

MOTOR WILL NOT RUN

1) Position panel switch in low-speed position. If motor can be heard running, check motor output shaft. If shaft is not turning, gearbox assembly requires replacement. If the shaft is turning, check drive link to output shaft for worn parts or disconnected components. If motor cannot be heard running, connect a voltmeter or test lamp between motor terminal "L" and ground.

2) If voltage is present and panel switch circuit breaker is not cycling, check for open ground circuit. Ground strap must make good contact. If motor runs, panel switch is not grounded, switch is faulty or there is an open in wiring. Common brush may not be making good contact with commutator and may require freeing-up or repositioning of spring. Armature may have an open circuit.

3) If voltage is present only part of the time, the circuit breaker is cycling. Problem may be a faulty circuit breaker or a short in the wiring, motor, or switch panel. Remove wiper arms and blades, disconnect harness at the motor and connect an ammeter between battery and terminal "L". If motor runs with average ammeter reading below six amperes, motor is

good and trouble is in switch panel or wiring. If motor does not run and draw is more than six amperes, check wiper linkage for binding. Disconnect drive link from motor. If motor runs and draws less than three amperes, repair linkage. If motor fails to run or draws more than three amperes, check motor and gearbox for internal jamming. If no internal jamming exists, check motor for brush leads shorting to housing or armature for burned or blackened windings which could indicate an internal short.

MOTOR RUNS AT LOW SPEED ONLY

Position switch in high position and connect test lamp between terminal "H" and ground. If lamp does not light, an open exists in wiring or switch. If lamp lights, brush is not making contact with armature.

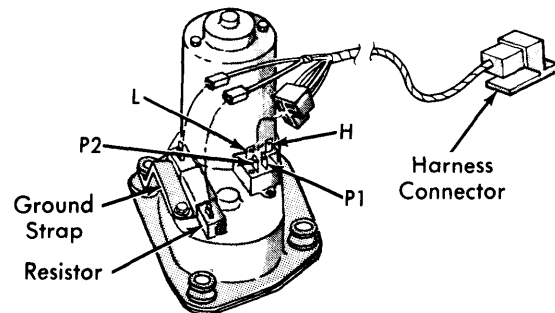

Fig. 1 2-Speed Wiper Motor Terminal Identification

MOTOR RUNS AT HIGH SPEED ONLY

Position switch in low position and connect test lamp between terminal "L" and ground. If lamp does not light, an open exists in wiring, switch or resistor. To check resistor, move test lamp from "L" terminal to terminal on resistor which has brown with yellow tracer wire. If lamp lights, replace resistor. If lamp lights at terminal "L", brush is not making contact with armature.

MOTOR CONTINUES TO RUN WITH SWITCH IN OFF OR PARK POSITION

Remove wiring harness and connect a jumper wire from terminal "P2" to terminal "L", then connect a jumper from "P1" to battery. If motor now runs to park position and stops, panel switch is defective. If motor continues to run and does not park, gearbox assembly requires replacement.

MOTOR WILL NOT STOP IN PARK POSITION WHEN SWITCH IS IN "OFF" POSITION

Remove wiring connector and clean terminals. If problem continues, place switch in park position and connect a voltmeter or test lamp between terminal "P1" and ground. If voltage is zero or test lamp does not light, problem is in panel switch or wiring. If 12 volts are present or lamp lights, check for voltage at "P2". If voltage is zero or test lamp does not light, motor park switch is defective and gearbox assembly must be replaced. If 12 volts are present or lamp lights, an open exists in panel switch or wiring.

CHRYSLER CORP. (Cont.)

WIPER SWITCH

Disconnect wiring from switch and remove switch from instrument panel. Use a continuity tester or ohmmeter to check for continuity between contact terminals of switch as shown in table. For test purposes, first position is "OFF", "LOW" is first detent from "OFF" position and "HIGH" is second detent from "OFF" position. Ground is the case of wiper switch.

Switch Continuity

OFF	LOW	HIGH
B to B/U	B to B/U	B to B/U
B to P1	B to P1	B to P1
A to P2	B to A	B to H
H-Open	P2-Open	P2-Open
Remove	H-Open	A-Open

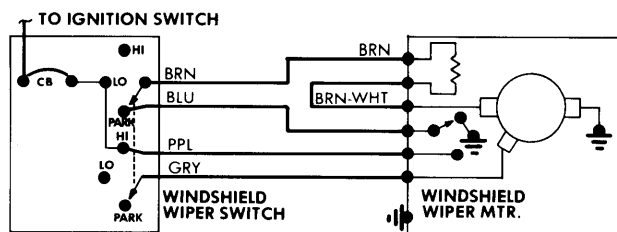

Fig. 2 Chrysler 2-Speed Wiper Wiring Diagram

REMOVAL & INSTALLATION

Disconnect battery cable, and wiring connector from motor and remove motor mounting screws. Lower motor far enough

to gain access to crank arm-to-drive link retainer bushing. Remove crank arm by prying retainer bushing from crank arm pin. Remove motor and nut attaching crank arm to motor drive shaft and crank arm from motor. To install, reverse removal procedure.

OVERHAUL

MOTOR

Disassembly - Hold wiper motor in a vise and remove housing through bolts. Remove housing and armature assembly. Remove flat washers and spring washer.

Reassembly - 1) Install brushes in slots and retain by locking brush lead wire into notches in rear of slots. Install flat washer, spring washer and flat washer on armature shaft. Install armature into bearing while turning shaft counterclockwise to mate shaft gear with intermediate gear. **NOTE** - Spin armature to make sure no binding exists between bearing and shaft.

2) Release brush lead wires from notches and allow brushes to contact commutator. All brush springs must be behind brushes and exert tension on brushes. Align motor housing window with brush holder and install over armature so housing is flush with gear housing and over four detents. **NOTE** - Install housing quickly so magnets in housing do not pull armature out of brush holder. Install through bolts and tighten. Tap assembly gently using a plastic mallet to align bearings in gear housing and motor housing during run period of bench check.

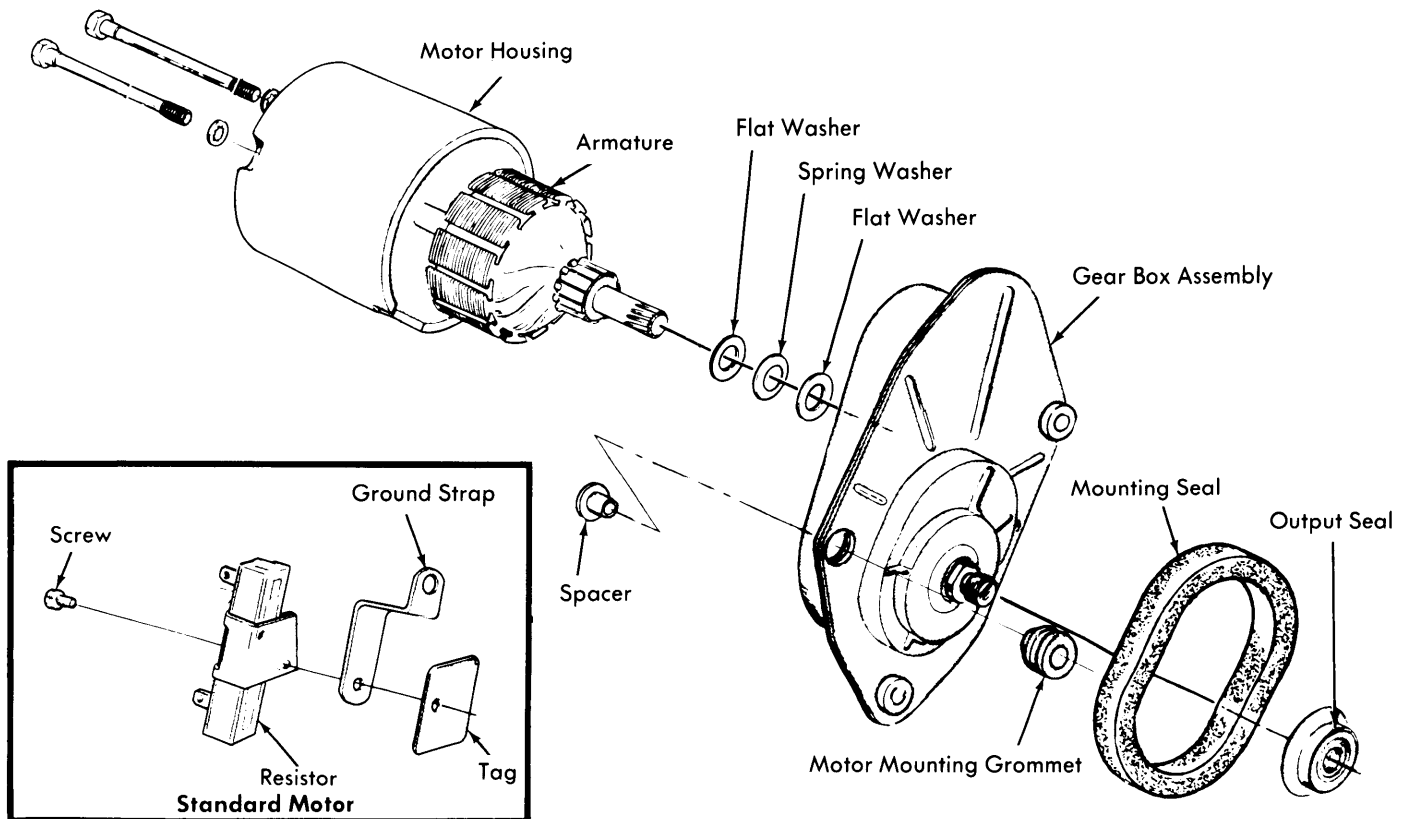

Fig. 3 Exploded View 2-Speed Wiper Motor