

MOTORCRAFT ALTERNATORS

Ford

DESCRIPTION

Alternator is belt driven from engine. Current is supplied from Alternator-Regulator system to rotating field of alternator through two brushes to two slip rings. Power is produced in the form of alternating current which is rectified to direct current by six diodes. Alternator regulator automatically adjusts alternator field current to maintain alternator output voltage within prescribed limits to correctly charge battery.

IDENTIFICATION & SPECIFICATIONS

Alternator is color-ink stamped with "Motorcraft" trademark. Color stamp is code for rated amperage output. Rated amperage is also stamped on end frame (40A, 60A, etc.). Color code is as follows:

Application	Amperage @ 15V.	Rated Output Speed (Engine RPM)
Orange	40	2900
Green	60	2900
Black	70	⓪1640
Red	100	⓪2900

⓪ — Rated cold output.

Specifications

Alternator	Specification
Field Current at 12 Volts (All)	4.0 Amps.
Slip-Rings (All)	
Minimum Diameter	1.22"
Maximum Runout.....	.0005"
Brush Length Wear Limit (All).....	5/16"
Pulley Nut Torque (All).....	60-100 ft. lbs.

CAUTION — When testing or servicing alternator or regulator, take following precautions to avoid damage to components:

Battery — Do not reverse battery connections. Negative terminal must be connected to ground. When charging battery, cables must be disconnected from battery before connecting charger. Do not use charger as a booster for starting engine. If booster battery is used to start engine, negative cable of booster must be connected to negative cable of vehicle battery.

Alternator — Do not ground field circuit between alternator and regulator, or operate alternator on an open circuit with field winding energized. Do not ground output terminal or attempt to polarize alternator as polarization is not required.

Regulator — Turn ignition switch off when working on regulator. Use care to prevent a short circuit between regulator relay and regulator base while working on components. Use insulated tools when making adjustments.

TESTING

VOLTMETER TEST PROCEDURES

NOTE — When performing charging system test with a voltmeter, turn off all lights and electrical components. Be sure battery specific gravity is at least 1.200.

1) Connect negative lead of voltmeter to negative battery post and positive lead to positive battery post. Record battery voltage.

2) Attach suitable tachometer and start engine. Operate at 1500 RPM with no electrical load, voltmeter reading should increase 1-2 volts above battery voltage. Reading should be taken when voltmeter needle stops moving.

3) With engine operating, turn on heater or A/C blower motor to "high" position and turn on headlights to high beam. Increase RPM to 2000, voltmeter should indicate a minimum of .5 volt increase over battery voltage. If system conforms to these readings, operation is normal.

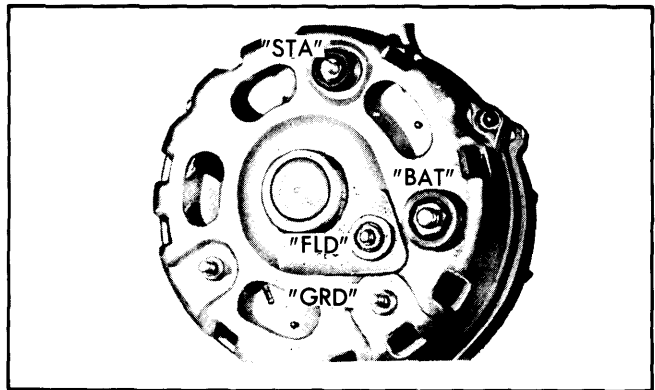

Fig. 1 View Showing Alternator Terminal Location on Rear Terminal Models

TEST RESULTS

1) If voltmeter reading indicates over-voltage (more than two volts above battery voltage), shut off engine and check ground connections between regulator and alternator and/or regulator and engine. Clean and tighten connections, then repeat tests.

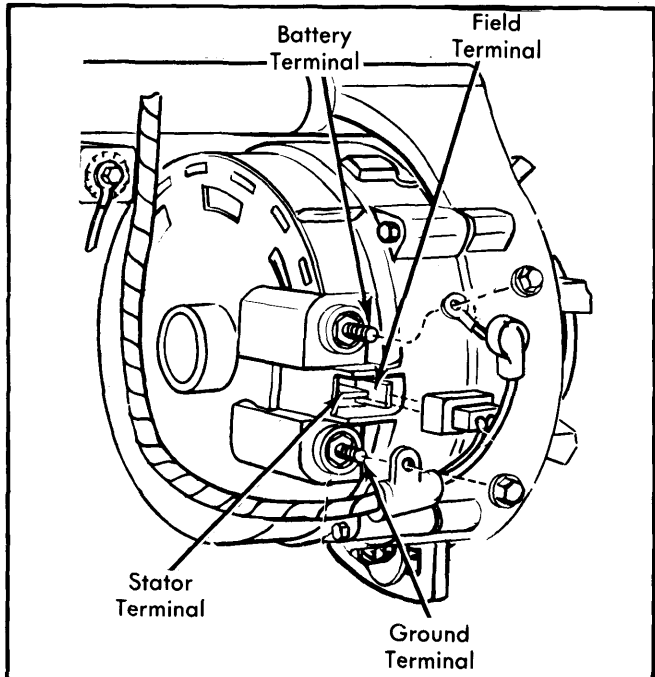

Fig. 2 View Showing Alternator Terminal Location on Side Terminal Models

MOTORCRAFT ALTERNATORS (Cont.)

2) If over-voltage condition still exists, disconnect regulator wiring plug and repeat steps 2) and 3) of "VOLTMETER TEST PROCEDURES". If condition is corrected, replace regulator and repeat test.

3) If over-voltage still exists with regulator disconnected, a short is indicated in wiring harness between alternator and regulator. Repair short circuit, then replace voltage regulator and repeat tests with regulator plug connected.

4) If voltmeter reading does not increase at least one volt, check for presence of battery voltage at alternator "BAT" terminal, and at regulator plug "A" terminal. If no voltage is present, an open wire is indicated. Repair wire and repeat tests.

FIELD CIRCUIT & ALTERNATOR TESTS

1) If field circuit is grounded and jumper wire is used as a check at regulator wiring plug from "A" to "F" terminals, excessive current will cause heat damage to regulator wiring plug terminals, and may burn jumper wire. If field circuit was grounded, connector wire inside regulator will also be burned open and will result in an under-voltage condition.

2) Field circuit should be checked with regulator wiring plug disconnected and suitable ohmmeter connected from "F" terminal of regulator wiring plug to battery ground. Ohmmeter should indicate between 4 and 250 ohms.

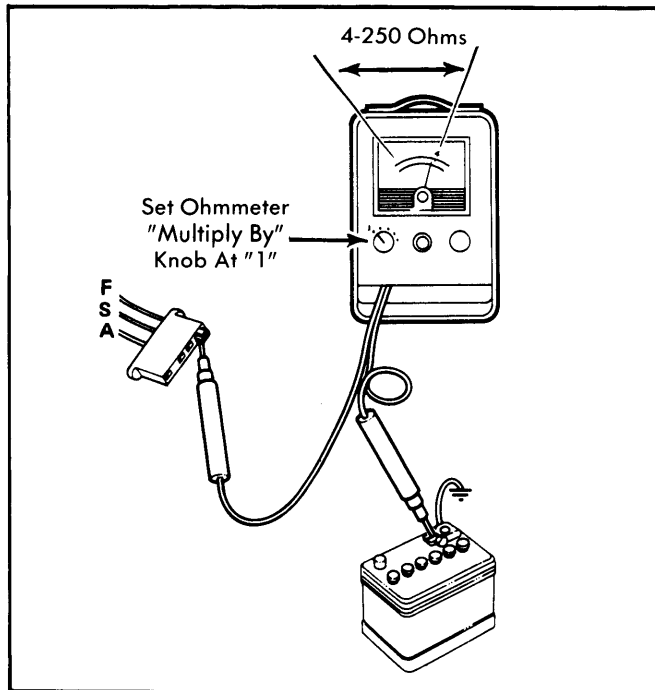

Fig. 3 Test Connections for Field Circuit Test

3) Check for regulator burned-open wire is made by connecting an ohmmeter from "I" to "F" terminals on regulator. If reading indicates approximately 10 ohms, connector wire inside regulator is burned open. Field circuit ground condition must be found and repaired before installing new regulator.

4) If field circuit is satisfactory, disconnect regulator wiring plug at regulator and connect jumper wire between "A" and "F" terminals on regulator wiring plug. Repeat voltmeter test procedures. If problem of under-voltage still exists, remove jumper wire at regulator plug and leave plug disconnected

from regulator, connect jumper wire to "FLD" and "BAT" terminals on alternator. Repeat voltmeter test procedures. If results are now satisfactory, repair wiring harness from alternator to regulator. If voltmeter tests still indicate under-voltage, repair or replace alternator.

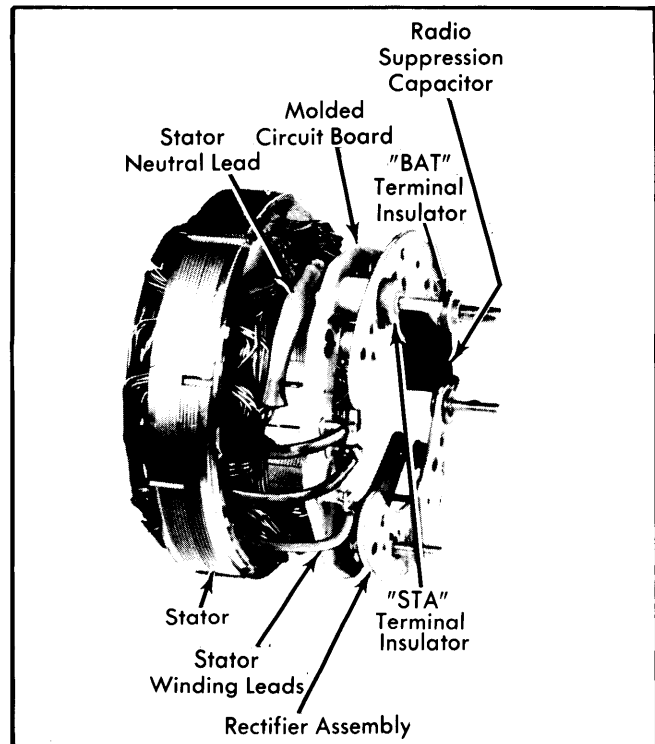

Fig. 4 View Showing Stator Lead Connections on Rear Terminal Models

REGULATOR CIRCUIT TESTS

"S" Circuit With Ammeter — Connect positive voltmeter lead to regulator wiring plug "S" terminal position. Turn ignition "ON", but do not start engine. Voltmeter should indicate battery voltage. If there is no voltage, the "S" wire lead from ignition switch is open. Repair and retest system.

"S" & "I" Circuit With Indicator Light — Disconnect regulator wiring plug and install a jumper wire between "A" and "F" terminals. With engine idling, connect positive lead of voltmeter to "S", and then "I" terminals of regulator wiring plug. Voltage of "S" circuit should be about $\frac{1}{2}$ of "I" circuit. If no voltage is present, repair alternator or wiring circuit at fault. If circuit tests are satisfactory, install a new regulator.

DIODE TEST (ON VEHICLE)

Disconnect electric choke (if equipped) and voltage regulator plug. Connect jumper wire between "A" and "F" terminals of voltage regulator wiring plug. Connect voltmeter to battery posts, start and run engine at idle speed, then record voltmeter reading. Move positive voltmeter lead to "S" terminal of alternator and note voltmeter reading. If meter reads $\frac{1}{2}$ of battery voltage, diodes are in working order. If meter reads approximately 1.5 volts, alternator has shorted negative diode or grounded stator winding. If meter reads approximately 1.5 volts less than battery voltage, alternator has

MOTORCRAFT ALTERNATORS (Cont.)

shorted positive diode. If meter reads approximately 1.0-1.5 volts less than $\frac{1}{2}$ of battery voltage, alternator has an open positive diode. If meter reads about 1.0-1.5 volts more than $\frac{1}{2}$ battery voltage, alternator has an open negative diode. Reconnect electric choke (if equipped) back into circuit after test is completed.

BENCH TESTS

Rectifier Shorted Or Grounded and Stator Grounded Test — Use an ohmmeter, set knob at "10", and calibrate as directed by manufacturer. Connect one ohmmeter probe to alternator "BAT" terminal and other probe to "STA" terminal and note reading. Reverse probes and note reading. A reading of 60 ohms should be observed in one direction and no movement with terminals reversed. A reading in both directions indicates a bad positive diode, grounded positive diode plate, or grounded "BAT" terminal. Perform same test using "STA" and "GRD" terminals. Readings in both directions indicate either bad negative diode, grounded stator winding, grounded stator terminal, grounded positive diode plate, or grounded "BAT" terminal. Infinite reading (no needle movement) in all four probe positions in the preceding tests indicates an open "STA" terminal lead connection inside alternator.

Field Open Or Short Circuit Test — Set ohmmeter knob at 1 and calibrate meter as directed by manufacturer. Contact alternator "FLD" terminal with one probe and "GND" terminal with other probe, then spin alternator pulley. Ohmmeter should read between 2.4 and 200 ohms, and should fluctuate while pulley is spinning. Infinite reading (no needle movement) indicates open brush lead, worn or stuck brushes, or bad rotor assembly. Meter reading of less than 2.4 ohms indicates grounded brush assembly, grounded field terminal, or bad rotor.

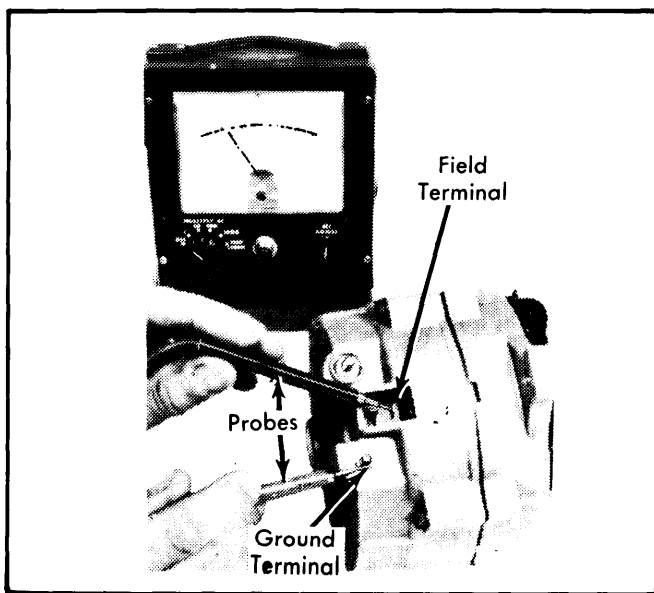

Fig. 5 Test Connections for Field Open or Short Circuit Test (Side Terminal Model Shown)

Diode Test — Remove rectifier assembly from alternator. Set meter knob at 10 and calibrate instrument. To test one set of diodes, contact one probe to terminal bolt and contact each of three stator lead terminals with other probe. Reverse probes

and repeat test. All diodes should show readings of about 60 ohms in one direction, and infinite readings with probes reversed. Repeat test for other set of diodes, moving first probe to other terminal screw. If meter readings are not as specified, replace rectifier assembly.

Stator Coil Open Or Grounded Test — Following tests are to determine if stator coil is operating properly. Disassemble stator from alternator. Set ohmmeter knob at 1 and calibrate. Connect meter probes between each pair of stator leads. Ohmmeter must show equal readings for each pair of stator leads. Replace stator if readings are not all equal. Set ohmmeter knob at 1000. Contact meter probe to one of stator leads and to stator laminated core, meter should show infinite reading (no needle movement). If meter needle moves, stator winding is shorted to core and must be replaced. Repeat test for each one of stator leads.

Rotor Open Or Short Circuit Test — Disassemble front housing and rotor from rear housing. Set ohmmeter knob at 1 and calibrate meter. Contact each probe to a rotor slip ring. Meter reading should be 2.4-4.9 ohms. Higher reading indicates damaged slip ring solder connection, or broken wire. Lower reading indicates shorted wire or slip ring. Replace rotor if damaged. Contact one meter probe to slip ring and other probe to rotor shaft. Meter reading should be infinite (no needle deflection), reading other than infinite indicates rotor is shorted to shaft. Replace rotor if shorted and cannot be repaired.

NOTE — Slip ring terminals or solder touching rotor shaft will cause shorted condition.

ADJUSTMENTS

ALTERNATOR REGULATOR

An electronic regulator is used on all charging systems. It is factory calibrated and cannot be adjusted.

OVERHAUL

E.E.D. REAR TERMINAL

Disassembly — 1) Mark both housings and stator with scribe for reassembly. Remove through bolts and separate front housing and rotor from stator and rear housing. Remove all nuts and insulators from rear housing. Remove rear housing from stator and rectifier assembly.

2) Remove brush holder mounting screws, holder, brushes, springs, insulator, and terminal. If replacement is necessary, press bearing from rear housing, supporting housing on inner boss. If rectifier assembly is being replaced, unsolder stator leads from rectifier terminals and separate stator from rectifier assembly.

NOTE — Use suitable 200 watt soldering iron.

3) Original production alternators will have one of two types of rectifier assembly boards; one has circuit board spaced away from diode plates with diodes exposed. The other type is single circuit board with built-in diodes. If alternator rectifier has exposed diode board, remove screws from rectifier by rotating bolt heads $\frac{1}{4}$ turn clockwise to unlock, and then remove screws. Push stator terminal straight out on a rectifier with diodes built into circuit board. Avoid turning screw while removing to make certain straight knurl will engage insulators when installing. Do not remove grounded screw.

MOTORCRAFT ALTERNATORS (Cont.)

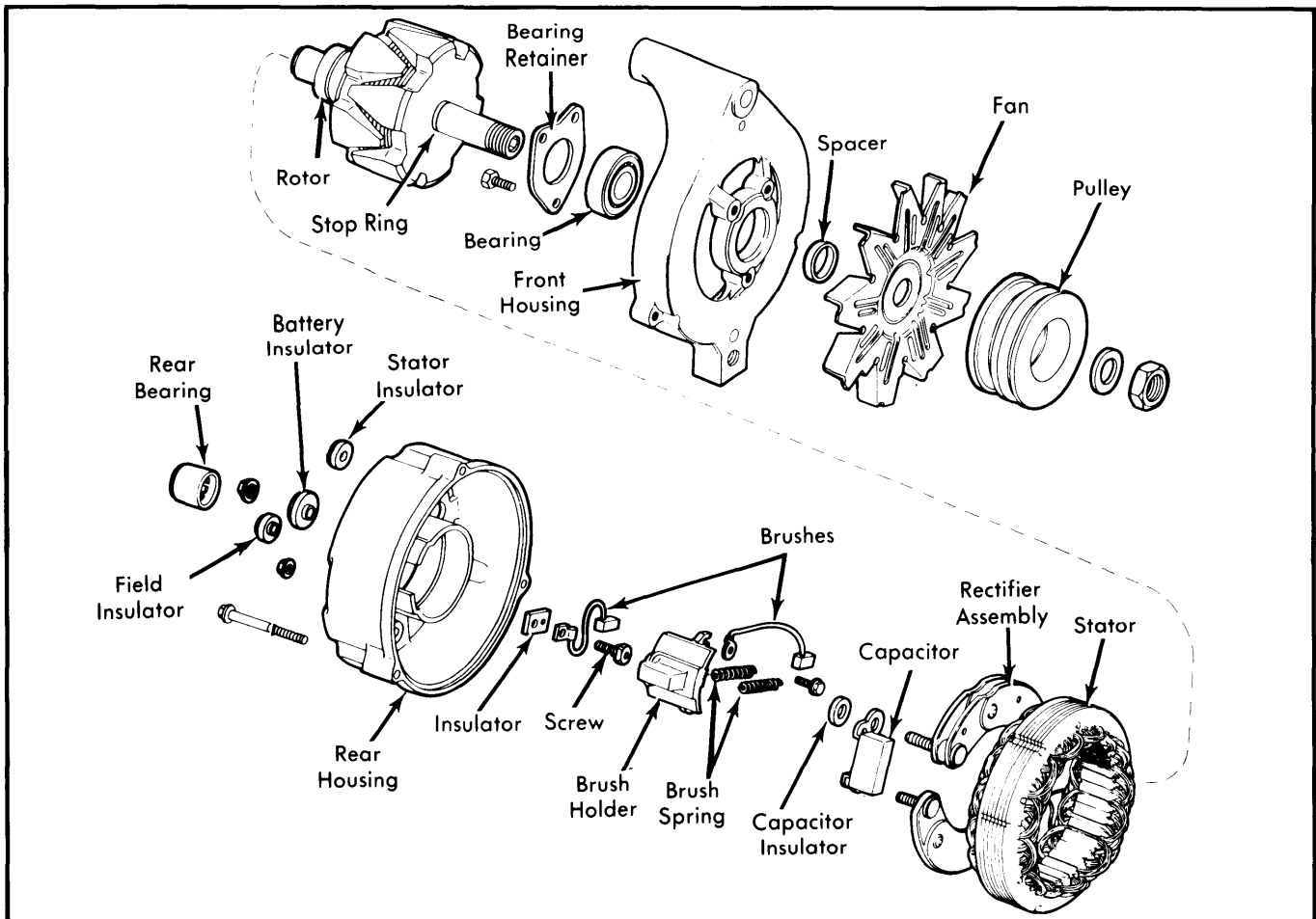

Fig. 6 Exploded View of Rear Terminal Alternator Assembly

4) Remove drive pulley nut using suitable tool; then, pull lock washer, pulley, fan, fan spacer, rotor and rotor stop from rotor shaft. Remove 3 screws holding front end bearing retainer and remove retainer. If bearing has lost lubricant or is damaged, support housing close to bearing boss and press out old bearing.

Reassembly - 1) Rotor, stator and bearing must not be cleaned with solvent. Wipe these parts off with a clean, lint-free cloth. Press front bearing in front housing bearing boss, putting pressure on bearing outer race only. Install bearing retainer. If stop-ring on rotor drive shaft is damaged, install new stop-ring. Push new ring on shaft and into groove.

NOTE - Do not open ring with snap ring pliers, as permanent damage will result.

2) Position rotor stop on drive shaft with recessed side against stop-ring. Position front housing, fan spacer, fan, pulley and lock washer on drive shaft and install retaining nut. Tighten retaining nut.

3) If rear housing bearing was removed, support housing on inner boss and press in new bearing flush with outer end surface. Place brush springs, brushes, brush terminal and terminal insulator in brush holder. Hold brushes in position by inserting small piece of stiff wire in brush holder. Position brush holder assembly in rear housing and install mounting screws. Position brush leads in holder.

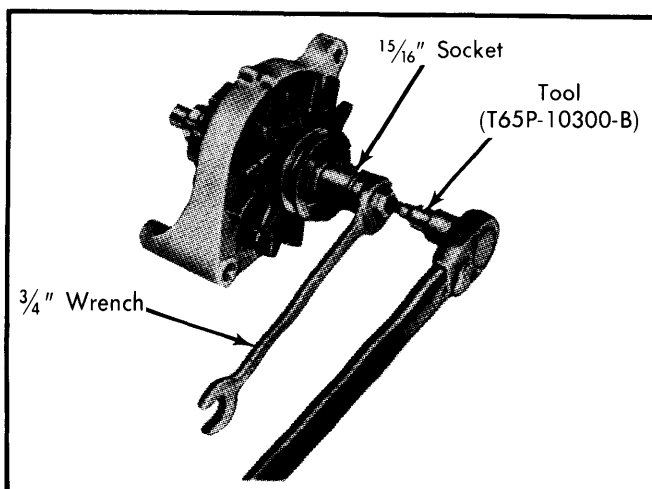

Fig. 7 Pulley Removal Procedure

MOTORCRAFT ALTERNATORS (Cont.)

4) Wrap three stator winding leads around rectifier terminals and solder using suitable 200 watt soldering iron and rosin-core solder. On 65 amp models, push terminals of stator wires onto circuit board terminals and solder. Position stator neutral lead eyelet on stator terminal screw and install screw in rectifier assembly.

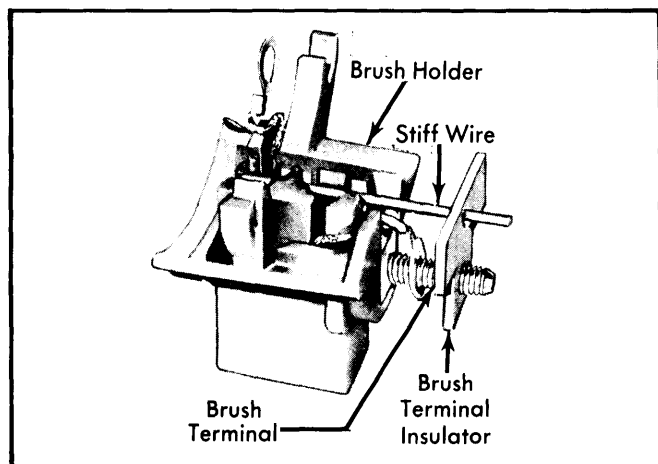

Fig. 8 Assembled View of Brush Holder Assembly

5) For rectifier with diodes exposed, insert special screws through wire lug, dished washers, and circuit board. Turn screw ¼ turn counterclockwise to lock. For single circuit boards with built-in diodes, insert screws straight through wire lug, insulating washer and rectifier, into insulator.

NOTE — Dished washers are to be used only on circuit board with exposed diodes. If dished washers are used on single circuit board, short circuit will occur. Flat insulating washers are to be used between stator terminal and board when single circuit board is used.

6) Position capacitor on rectifier terminals. On circuit board with exposed diodes, install "STA" and "BAT" terminal insulators. On single circuit board, position square stator terminal insulator in rectifier assembly. Position "BAT" terminal insulator on "BAT" terminal. Position stator and rectifier assembly in rear housing. Make certain all terminal insulators are seated properly in appropriate recesses. Position "STA" (black), "BAT" (red), and "FLD" (orange) insulators on terminal bolts and install retaining nuts.

7) Wipe rear end bearing of rotor shaft with clean, lint free cloth. Position rear housing and stator assembly over rotor and align scribe marks made during initial disassembly. Seat machined portion of stator core into step in both end housings. Install housing through bolts. Remove brush retracting wire, and put small amount of water-proof cement over hole to seal from moisture.

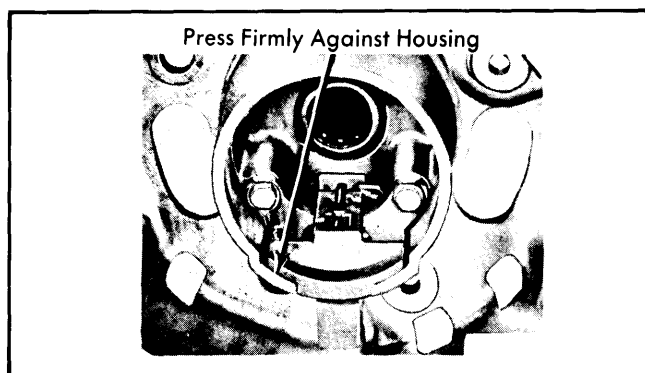

Fig. 9 View Showing Brush Lead Wire Routing

G.P.D. SIDE TERMINAL

Disassembly — 1) Mark both housings and stator with scribe for reassembly. Remove through bolts and separate front housing and rotor from rear housing and stator. Do not separate rear housing from stator at this time. Remove drive pulley nut; then, remove lock washer, pulley, fan and fan spacer from rotor shaft.

2) Remove rotor and shaft from front housing, then remove spacer from rotor shaft. Remove three screws holding front bearing to housing. If bearing is damaged or has lost lubricant, support housing close to bearing boss and press bearing from housing. Unsolder stator leads from rectifier assembly using a 200 watt soldering iron.

3) Remove stator from rear housing. Unsolder brush holder from rectifier using a 200 watt soldering iron. Remove capacitor lead-to-rectifier screw. Remove four rectifier-to-rear housing screws. Remove two terminal nuts and insulator from outside of housing, then remove rectifier assembly from housing.

4) Remove two brush holder-to-housing screws, then remove brushes and holder. Clean all sealing compound from rear housing and brush holder. Remove capacitor from rear housing. If necessary to replace rear bearing, support rear housing near bearing boss and press bearing out of housing from the inside.

Reassembly — 1) Rotor, stator, and bearings must not be cleaned with solvent. Wipe these parts off with a clean, lint-free cloth. Press front bearing into front housing, putting pressure on bearing outer race only. Install bearing retaining screws. Install inner spacer on rotor shaft and install shaft into front housing and bearing.

2) Install fan spacer, fan, pulley, lock washer, and nut onto rotor shaft. Tighten pulley nut. If rear bearing was removed, press new bearing in until it is flush with boss outer surface. Position brush terminal, springs, and brushes in brush holder and hold in position by inserting a small piece of stiff wire in brush holder.

Alternators & Regulators

MOTORCRAFT ALTERNATORS (Cont.)

3) Install brush holder to rear housing and install attaching screws. Push brush holder toward rotor shaft opening and tighten screws. Install capacitor to rear housing and install attaching screw. Install two rectifier insulators on bosses inside rear housing. Install insulator on "BAT" terminal of rectifier, then position rectifier in rear housing.

4) Install outside insulator on "BAT" terminal, then install nuts on "BAT" and "GRD" terminals finger tight. Install four rectifier attaching screws but do not tighten. Tighten terminal nuts on "BAT" and "GRD" terminals, then tighten four rectifier screws. Secure capacitor lead to rectifier. Press brush holder lead on rectifier pin and solder using a 200 watt soldering iron.

5) Install stator in rear housing and align scribe marks. Press three stator leads onto rectifier pins and solder using a 200 watt soldering iron. Position rotor and front housing into stator and rear housing while aligning scribe marks. Install four through bolts and tighten. Spin fan and pulley to ensure nothing is binding inside alternator. Remove brush retracting wire, and put small amount of water-proof cement over hole to seal from moisture.

BRUSH REPLACEMENT

E.E.D. Rear Terminal – 1) Remove brush holder and cover assembly from rear housing. Remove terminal bolts from brush holder and cover assembly and remove brush assemblies. Posi-

tion new brush terminals on terminal bolts and assemble terminals, bolts, and brush holder washers, and nuts. Insulating washer mounts under "FLD" terminal nut. Entire brush and cover assembly is also available for service.

2) Depress brush springs in brush holder cavities and insert brushes on top of springs. Hold brushes in position by inserting a stiff wire in brush holder. Position brush leads as required. Install brush holder and cover assembly to rear housing. Remove brush retracting wire and seal with small amount of water-proof cement.

G.P.D. Side Terminal – 1) Mark both end housings and stator with a scribe. Remove four through bolts and separate front housing and rotor from rear housing and stator. Use a 200 watt soldering iron to unsolder and detach brush holder lead from rectifier. Remove brush holder attaching screws and remove holder from rear housing. Remove any sealing compound.

2) To install, position holder to rear housing and insert wire, to retract brushes, through hole in rear housing. Install holder attaching screws, push holder toward rotor shaft and tighten screws. Press holder lead on rectifier pin and solder using a 200 watt soldering iron. Install front housing and rotor to rear housing and stator while aligning scribe marks. Install four through bolts, then spin fan and pulley to ensure nothing is binding inside alternator. Remove wire, retracting brushes, and seal with a small amount of water-proof cement.

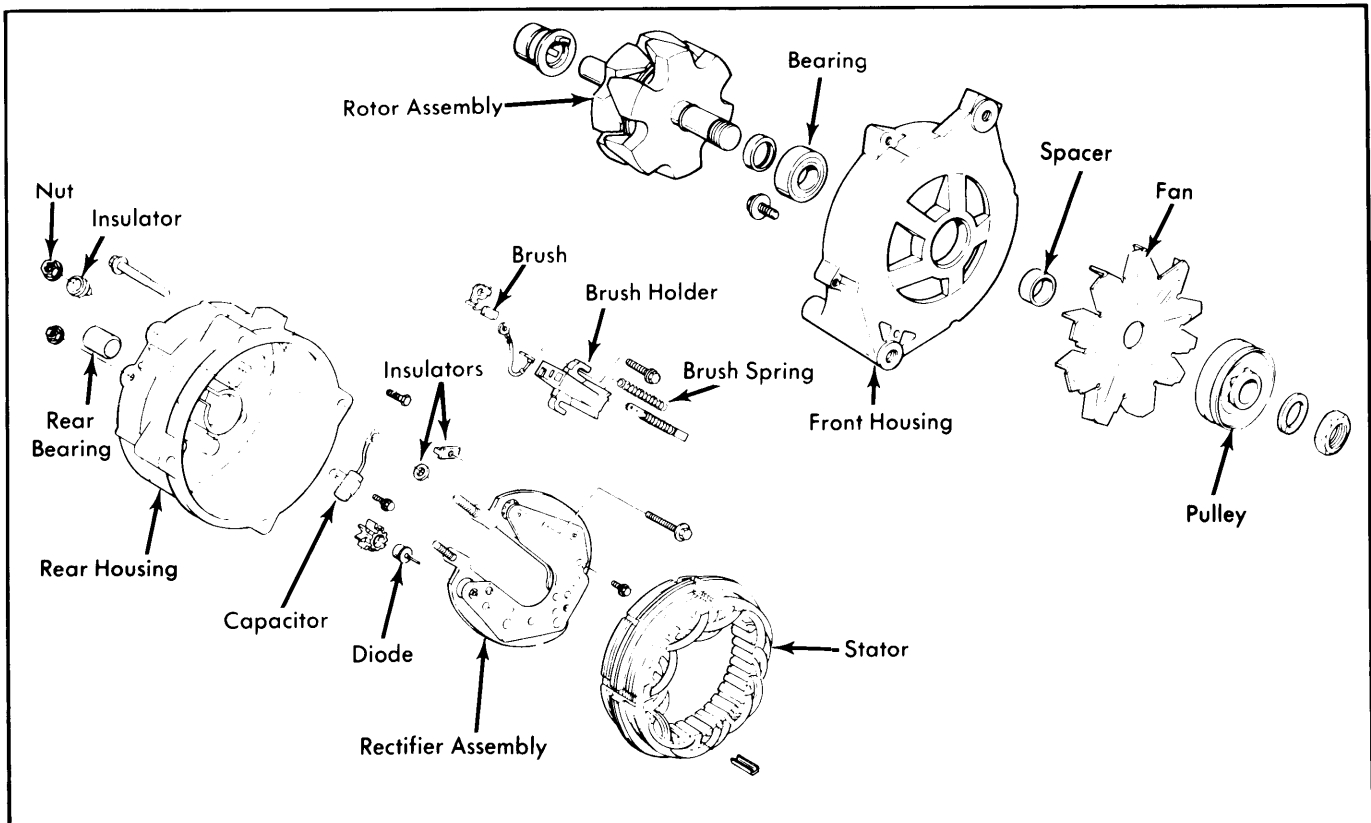

Fig. 10 Exploded View of Side Terminal Alternator Assembly