

JEEP CRUISE COMMAND

Jeep
Cherokee
Wagoneer
"J" Models

DESCRIPTION

System senses car speed through speedometer cable and uses engine intake manifold vacuum to regulate accelerator and automatically maintain any pre-set cruising speed between 30 and legal speed limit.

OPERATION

Cruise Command control is an integral part of the directional switch lever and consists of two separate switches. The first is "OFF-ON" and "RES" (resume) slide switch located on the flat of directional switch lever. Second is a push button switch located at the end of directional switch lever. To engage system, move slide switch to "ON" position and accelerate to desired speed. Depress and release button on end of switch lever. System will now maintain selected speed. System will automatically disengage when brake pedal is depressed and can be re-engaged to previously selected speed by accelerating to 30 MPH and moving slide switch to "RES" position, then releasing switch.

NOTE — When slide switch is moved to "OFF" position, Pre-set speed of "RES" function is canceled and must be reset when system is reactivated.

A higher speed can be set by pressing on accelerator pedal until new speed is reached and then pushing control button. A lower speed can be achieved by lightly depressing brake pedal, allowing vehicle to slow to desired speed and then depressing and releasing push button. Operation of individual components is as follows:

Regulator — Senses speed through speedometer cable located between transmission and regulator. Fly-weight type governor reacts to cable speed and engages low speed switch at approximately 30 MPH. When low speed switch is closed, driver may engage system. Regulator is serviced as an assembly.

Vacuum Servo — A neoprene bellows that receives modulator vacuum and actuates throttle to control vehicle speed.

Control Switch — An integral part of turn signal lever, when actuated, it will energize either solenoid valve or coupling coil (or both), thereby controlling speed.

Relay — Relay is energized when ignition switch is turned to "ON" position. It prevents battery drain when ignition switch is turned to "OFF."

Release Switch — Disengages system when brake pedal is depressed.

TROUBLE SHOOTING & DIAGNOSIS**SYSTEM WILL NOT ENGAGE**

System harness fuse blown. Defective brake light switch. Vacuum leak. Bad regulator ground or electrical connections. Brake light fuse or lamp burnt out. Defective engaging switch or regulator. No current to brown wire. Bad relay or relay ground. Solenoid valve deformed.

SYSTEM DOES NOT DISENGAGE WHEN BRAKES APPLIED

Defective brake light switch, collapsed servo-to-regulator hose or 250 mfd. capacitor shorted.

SYSTEM RE-ENGAGES WHEN BRAKES RELEASED

Defective engagement switch. Improper location of wiring in connectors. Solenoid valve deformed.

CARBURETOR DOES NOT RETURN TO NORMAL IDLE, PULSATING ACCELERATOR PEDAL

Throttle chain linkage adjustment incorrect. Lack of lubrication or kinked speedometer or drive cable.

SPEEDOMETER INOPERATIVE, SYSTEM STILL OPERATES

Speedometer not driven by cable. Defective regulator.

SPEEDOMETER & SYSTEM INOPERATIVE

Transmission cable not driving regulator.

SPEED 3 OR MORE MPH ABOVE OR BELOW SELECTED SPEED

Adjustment of regulator incorrect.

SYSTEM DISENGAGES ON LEVEL ROAD WITHOUT APPLYING BRAKE

Loose electrical connections or ground. Loose hoses. Broken servo linkage chain or slipped throttle clevis. Oversensitive stop lamp switch.

ERRATIC OPERATION OF SYSTEM

Inspect vacuum servo or vacuum hoses. Inspect regulator.

SYSTEM CONTINUES TO ACCELERATE AFTER ENGAGEMENT

Open circuit in green wire attached to No. 4 terminal at regulator

VEHICLE LOSES SPEED ON HILLS

Excessive slack in servo chain. Lack of engine manifold vacuum.

STOP LIGHT FUSES BLOWING

Shorted 250 mfd. capacitor.

BLOWING FUSES

Short or ground in system wiring circuit.

SYSTEM ENGAGES WHEN TURN SIGNAL SWITCH IS OPERATED

Open 250 mfd. capacitor. Stop or turn lamp bulb burned out on side opposite direction of turn.

JEEP CRUISE COMMAND (Cont.)

TESTING

All tests of system should be performed as part of diagnosis of malfunction and to determine procedure(s) required for system repair. Five separate circuits are used in system. These circuits are: slide switch in "ON" position, push button depressed, push button released, brake release, and slide switch in "RESUME" position.

NOTE – Whenever a unit is disconnected for testing, it should be reconnected before next unit is tested.

CONTROL SWITCH CONTINUITY

Control switch continuity test is performed at steering column using an ohmmeter. Refer to following chart to determine switch continuity condition.

NOTE – Pushbutton cannot be depressed with slide switch in "RES" position.

Control Switch Continuity Conditions

Application	Switch Position	Condition
Red/Brown	"OFF"	Open
Red/Green	"OFF"	Open
Red/Yellow	"OFF"	Open
Red/Brown	"ON"	Closed
Red/Green	"ON"	Closed
Red/Yellow	"ON"	Open
Red/Brown	"RES"	Closed
Red/Green	"RES"	Closed
Red/Yellow	"RES"	Closed
Red/Brown	"ON"⓪	Closed
Red/Green	"ON"⓪	Open
Red/Yellow	"ON"⓪	Closed

⓪ – Pushbutton depressed.

ELECTRICAL TESTS

NOTE – If system is inoperative, it is not always necessary to remove regulator.

1) Disconnect both single and triple push-on connectors at regulator. Turn ignition switch to "ACC" and move slide switch to "ON" position. Perform the following tests using a suitable test lamp.

2) Ground one test lamp lead and touch other to brown wire and then green wire at connectors. Test lamp should light at both wires. If lamp does not light, check fuse, speed control relay, engagement switch, and connection at power source.

3) Hold "SET SPEED" button all the way in. Ground one test lamp lead and touch other to each wire in connector. Lamp should light at brown and yellow wires and should not light at green or blue wires. Release "SET SPEED" button.

4) Hold slide switch in "RES" position. Ground one test lamp lead and touch other to each wire in connector. Lamp should light at all wires except blue wire. Blue wire connects to brake lamp side of brake lamp switch.

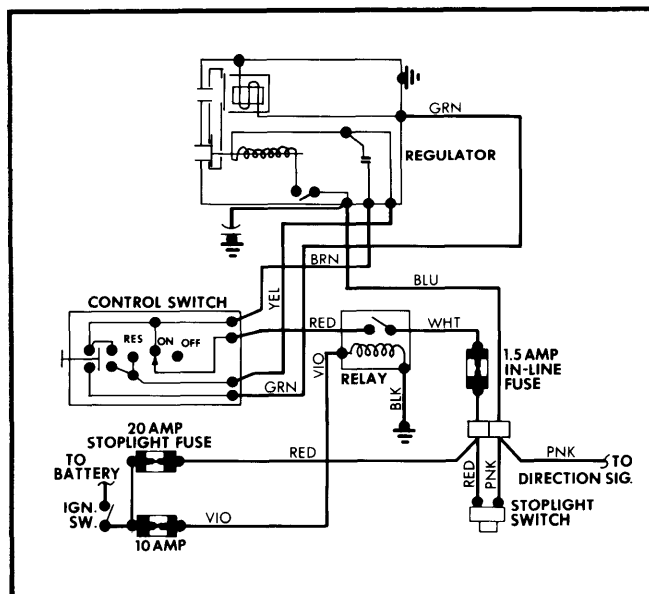

Fig. 1 Jeep Cruise Command System Wiring Diagram

NOTE – The following tests need not be done if preceding tests checked out. If the preceding tests did not check out, perform the following tests.

5) Disconnect engagement switch from wiring harness at multiple connector in passenger compartment. Attach a jumper wire from a 12 volt power source to engagement switch red lead.

6) Move slide switch to "OFF" position. Ground one test lamp lead and touch other (in turn) to brown wire, green wire and then yellow wire. Lamp should not light at any wire.

7) Move slide switch to "ON" position. Ground one test lamp lead and touch other to brown wire and then green wire. Lamp should light on both wires. Touch test lamp lead to yellow wire. Lamp should not light.

8) Hold "SET SPEED" button all the way in. Ground one test lamp lead and touch other to brown wire and yellow wire. Lamp should light on both wires. Touch test lamp lead to green wire. Lamp should not light. Release "SET SPEED" button.

9) Hold slide switch in "RES" position. Ground one test lamp lead and touch other (in turn) to brown wire, yellow wire and then green wire. Lamp should light at all wires. Release slide switch.

NOTE – If test procedures 1) through 4) do not check out, but procedures 5) through 9) do check out, replace Cruise Command system wiring harness. If all test procedures do not check out, replace engagement switch.

BRAKE RELEASE SWITCH TEST

NOTE – The brake release switch is part of the stoplamp switch. The stoplamp circuit must be operating correctly before testing brake release switch.

JEEP CRUISE COMMAND (Cont.)

Disconnect triple wire connector at regulator. Using a suitable test lamp, ground one test lamp lead and touch other to blue wire. Lamp should not light. If it does, wire is connected to wrong side of stoplamp switch. With brake pedal depressed $\frac{1}{4}$ ", test lamp should light. If not, check fuse, stoplamp switch, wiring harness to regulator or power source connection.

SPEED CONTROL RELAY TEST

1) The speed control relay is mounted close to fuse panel under instrument panel. Check all electrical connections before testing relay. Turn ignition switch on and move slide switch to "ON" position. Using a suitable test lamp, ground one test lamp lead and touch other to each connector at relay. Test lamp should light at each connector wire except ground.

2) If test lamp lights on the white and violet connectors but does not light on red connector, replace relay. If test lamp does not light on white and violet connectors, check fuse, wiring harness and power source connection.

ADJUSTMENT

VACUUM SERVO CHAIN

NOTE — Before adjusting servo chain, carburetor throttle must be at idle position, ignition must be off and choke valve fully open.

To install vacuum servo chain, insert chain in vacuum servo hook. Stretch chain linkage to carburetor until chain is fully extended and clevis pin hole aligns with hole in throttle lever. If holes do not line up, adjust chain at servo hook (one ball at a time) until free pin fit is obtained. When properly adjusted, there should be a slight deflection in chain without moving either carburetor throttle lever or servo. After adjustment, bend servo hook tabs together.

NOTE — Chain must be free in hook after bending tabs.

CENTERING SPRING

NOTE — Adjustment of centering spring is extremely sensitive. Adjustment screw must never be turned more than $\frac{1}{8}$ turn in either direction.

Cruise command system is designed to maintain speed designated by driver, within 3 MPH. System operation is checked at 50 MPH. Speed change is made by adjusting spring centering screw. If speed control holds speed more than 3 MPH above designated speed, turn centering spring screw "C" toward "S", but no more than $\frac{1}{32}$ turn. If speed is more than 3 MPH below designated speed, turn centering spring screw "C" toward "F", but no more than $\frac{1}{32}$ turn.

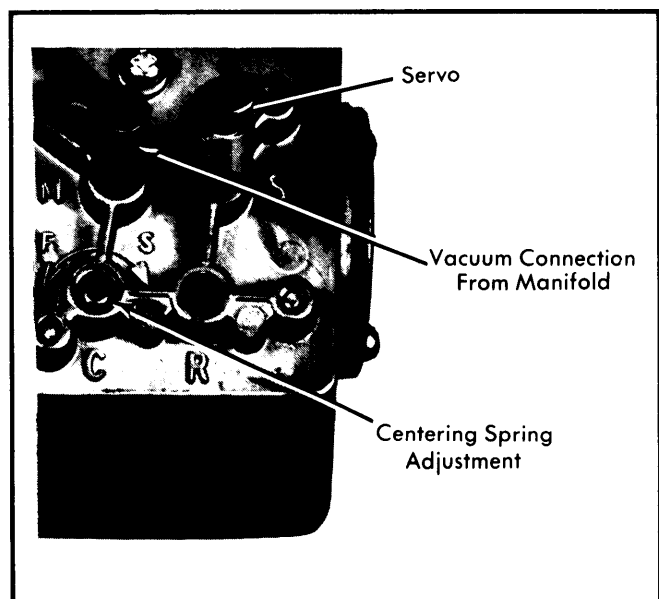

Fig. 2 Identification of Adjustment Screw