

CHRYSLER CORP. - SOLENOID ACTUATED

Chrysler Corp.

DESCRIPTION

The electric door lock system is solenoid actuated at each door and can be locked or unlocked electrically by operating either left or right front locking knobs. Side and rear doors, when electrically equipped can be actuated by operation of front locking knobs. All doors must be closed before locking. They can be locked or unlocked manually with key or electrically as described. The system combines a relay, circuit breaker, and "button" head terminals in door and post panels to combine all door wiring into 1 wiring harness. The relay and circuit breaker are mounted to steering column support bracket on underside of dash. All components are serviced as complete assemblies.

ELECTRICAL TESTS

- 1) With battery in normal operating condition and solenoid adjusted properly, connect positive lead of voltmeter to buss bar on relay assembly and negative lead to ground.
- 2) With no load, voltage should be approximately 12.5 volts. When locks are operated, voltage should be 11 volts. If no voltage is read at relay, test circuit breaker as follows:
- 3) Connect positive voltmeter lead to light green terminal of circuit breaker, and negative lead to ground. If reading of 12.5 volts is not obtained, connect positive lead to battery side of circuit breaker.
- 4) If 12.5 volts are obtained, the circuit breaker is defective and should be replaced. If 12.5 volts are not obtained, check for broken feed wire or loose connection.

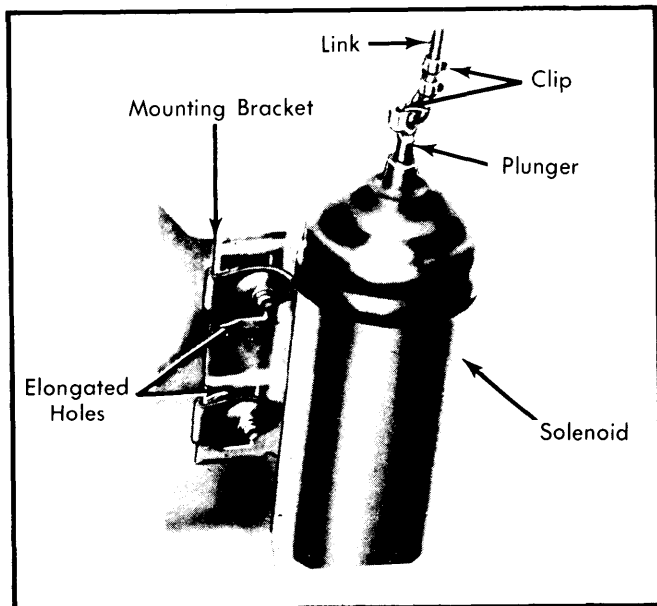

Fig. 1 Electric Door Lock Solenoid

- 5) To check for faulty solenoids, disconnect the solenoid connectors one at a time while operating the door lock switch. If none of the solenoids work, the problem may be a shorted solenoid or faulty relay. If defective solenoid is found, disconnecting it will allow the remaining solenoids to operate, provided the relay is not damaged.

ADJUSTMENT

DOOR LOCK SOLENOID

Remove door trim panel. Loosen solenoid attaching screws. While pressing down on the lock knob, push up on the solenoid until the solenoid plunger bottoms out in the solenoid. Tighten screws and test operation before installing trim panel.

REMOVAL & INSTALLATION

DOOR LOCK SOLENOID

- 1) Remove inside door release handle, window regulator handle and door trim panel.
- 2) Roll door water shield away from lower rear corner of door to reveal inside panel access opening.
- 3) Remove solenoid link at solenoid. Disconnect solenoid lead wires. Remove mounting bracket attaching screws and remove solenoid from mounting.
- 4) To install, reverse removal procedure and adjust if necessary.

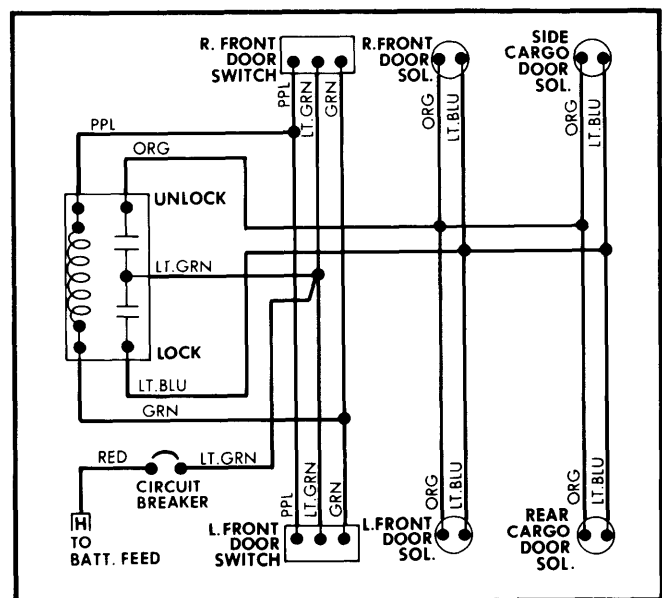

Fig. 2 Chrysler Corp. Light Truck Power Door Lock Wiring Diagram