

## JEEP – MOTOR ACTUATED

Jeep

## TESTING

## DESCRIPTION

Jeep vehicles with power door locks use a battery powered, motor actuated lock system controlled by two rocker switches. Pressing up on the switch unlocks doors, or pressing down on the switch locks the doors. Power door locks are protected by a 30 amp. circuit breaker located in the fuse block. Two-door models have the wiring harness running from door-to-door and is secured at the instrument panel with retainers. Four-door models have the wiring harness for the back doors connected to the front door harness at the side cowl panels.

## REMOVAL &amp; INSTALLATION

## DOOR LOCK SWITCH

- 1) Disconnect negative battery cable. Remove door trim panel. Remove switch housing from inner door panel.
- 2) Disconnect wiring and remove switch assembly. Pry clips holding connector up, to disconnect. Depress retainer clips through holes in switch housing and remove switch.
- 3) To install, reverse removal procedures.

## ACTUATOR MOTOR

- 1) Disconnect negative battery cable. Remove door trim panel.
- 2) Remove actuator motor by drilling out rivets attaching motor to door panel with a  $\frac{1}{8}$ " drill bit. Disconnect actuator rod from bellcrank.
- 3) Disconnect wires from actuator motor and remove motor. To install, reverse removal procedures making sure to install new rivets.

## SWITCH

Test switches for continuity using an ohmmeter. Connect ohmmeter across terminals as shown in Fig. 1. Continuity should exist between terminals in all positions.

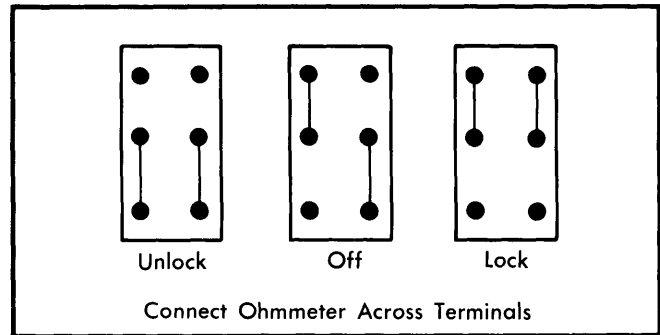

Fig. 1 Checking Switch for Continuity

## ACTUATOR MOTOR

Connect ammeter to motor terminals and operate door switch. If current draw exceeds 8 amps. at room temperature or if actuator does not complete its travel within 1 second, replace actuator motor.

## CIRCUIT BREAKER

Disconnect harness connector from fuse block. Test fuse block connection with test light. If light operates, battery voltage is present. If light stays off, remove circuit breaker and test with ohmmeter. If circuit breaker tests okay, check for battery voltage at circuit breaker connection at fuse block. If no battery voltage at connection, check for breakage of fusible link in engine compartment.

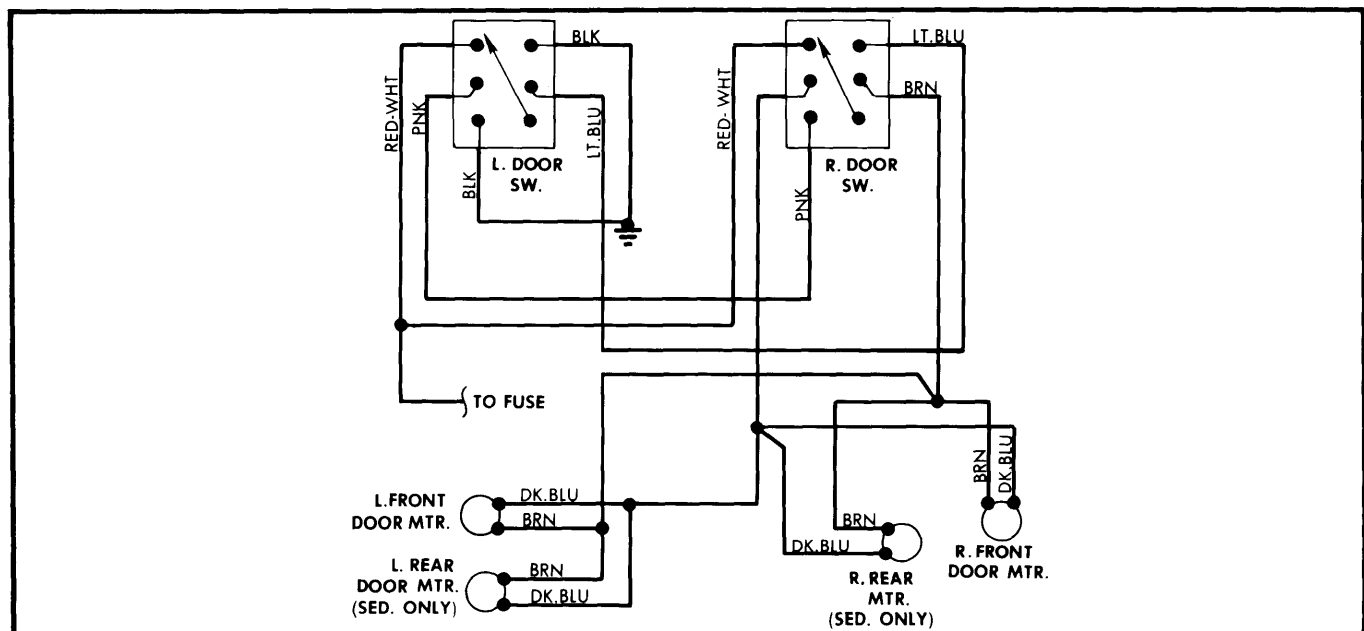

Fig. 2 Wiring Diagram For Jeep Power Door Locks (2-Door and 4-Door Models)