

General Motors V8 Engines

350" & 400" V8 ENGINES

| GENERAL SPECIFICATIONS | | | | | | | |
|------------------------|-----------------|------------|-----------|--------------------------|--------------|--------|--------|
| Year | Displ. Cu. Ins. | Carburetor | HP at RPM | Torque (Ft. Lbs. at RPM) | Compr. Ratio | Bore | Stroke |
| 1975 | 350" | 2-Bbl. | | | 8.5:1 | 4.000" | 3.480" |
| | 350" | 4-Bbl. | | | 8.5:1 | 4.000" | 3.480" |
| | 400" | 4-Bbl. | | | 8.5:1 | 4.125" | 3.750" |

ENGINE IDENTIFICATION

Engine code letters are suffix of Engine Identification Number. Number is stamped in pad on front right side of cylinder block.

Chevrolet & GMC

| Application | Code |
|------------------------------|---|
| 350" Man. Trans. | |
| Calif. | TXY, TXM, TYS, TYJ, TXJ, TXC, TYD, TYW |
| Calif. W/A.I.R. & CAT..... | TZL, TZJ |
| Federal..... | TXX, TXR, TZF, TYT, TYA, TXK, TYC, TXD, TYX, TZC |
| Federal W/A.I.R. & CAT. | TKE, TMF, TJN, TKN |
| 350" Auto. Trans. | |
| Calif. | TXS, TXW, TMG, TYR, TXH, TME, TYY, TXA |
| Calif. W/A.I.R. & CAT. | TZM, TZK |
| Federal..... | TXS, TXT, TKG, TYU, TXL, TKF, TZA, TYZ, TXB |
| Federal W/A.I.R. & CAT. | TZH, TZB, TJE, TZD, TJJ |
| 400" | |
| Calif. | TLL, TLR, TLD, TLT |
| Federal..... | TLM, TLS, TLH, TLU |

ENGINE REMOVAL

See Engine Removal at end of ENGINE Section.

INTAKE MANIFOLD

Removal - 1) Drain cooling system and remove air cleaner. Disconnect battery cables at battery, upper radiator hose and heater hose at engine. Disconnect gas line, all vacuum lines and accelerator linkage at pedal lever.

2) Remove distributor cap, note position of rotor with chalk and remove distributor. Remove (if equipped or necessary) oil filler bracket, coil, air compressor and bracket, accelerator bellcrank, and accelerator return spring and bracket.

3) Remove all manifold retaining bolts and pry intake manifold loose from cylinder heads. Remove intake manifold and carburetor as an assembly.

Installation - To install intake manifold, clean all gasket surfaces and apply sealer at all water passages and at positions where seals butt together. Install manifold and tighten bolts in sequence shown in illustration. Install distributor noting marked position of rotor. To complete installation, reverse removal procedure.

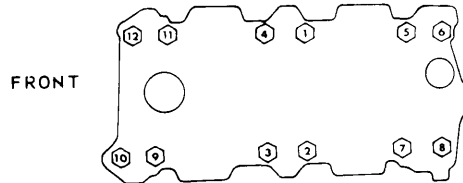

FRONT

3GM01

INTAKE MANIFOLD TIGHTENING SEQUENCE

CYLINDER HEAD

Removal - 1) Remove intake manifold as previously outlined. Remove carburetor air heater from exhaust manifold if equipped. Remove spark plug shields and disconnect exhaust pipe from manifolds and remove exhaust manifolds.

2) Disconnect ventilation hose from valve cover and remove both valve covers. Loosen rocker arm nuts and pivot rocker arms to side to remove push rods. Mark position of push rods to ensure that they are installed in same position.

3) Drain cylinder block of all coolant and remove all cylinder head bolts. Pry cylinder head loose from cylinder block and remove both heads.

Installation - Gasket surfaces of both head and cylinder block must be clean. Use sealer if equipped with steel gasket. If asbestos gasket is being used, sealer is not required. Position heads and gaskets on cylinder block. Coat threads of bolts with a sealing compound. Tighten cylinder head bolts in sequence shown in illustration. To complete installation, reverse removal procedure.

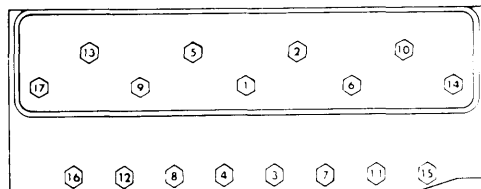

3GM02

CYLINDER HEAD TIGHTENING SEQUENCE

350" & 400" V8 ENGINES (Cont.)

| VALVES | | | | | | | |
|----------------|------------|------------|------------|------------|---------------|----------------|------------|
| Engine & Valve | Head Diam. | Face Angle | Seat Angle | Seat Width | Stem Diameter | Stem Clearance | Valve Lift |
| 350" & 400" | | | | | | | |
| Int. | 1.940" | 45° | 46° | .031-.063" | .3410-.3417" | .0010-.0027" | |
| Exh. | 1.500" | 45° | 46° | .063-.094" | .3410-.3417" | .0010-.0027" | |

VALVE ARRANGEMENT

E-I-I-E-E-I-I-E (Both sides, front to rear.)

VALVE GUIDE SERVICING

If valve stem to guide clearance is excessive, valves with over-size stems are available. Oversize valve stems are available .003", .015" and .030" oversize. Using a suitable reamer (Reamer Kit No. J-5830) ream guides to correct size for over-size valve stems.

VALVE STEM OIL SEALS

A small "O" ring type seal is installed in second groove of valve stem before keepers are installed. See *Valve Springs*.

VALVE SPRING INSTALLED HEIGHT

Valve spring installed height is measured from top of shim, at bottom of spring, or spring seat to top of valve spring or spring shield. If distance exceeds specified height, install a $\frac{1}{16}$ " thick shim. Installed height should never be more than $\frac{1}{16}$ " less than specified height.

| Application | Valve Spring Installed Height | Height |
|-------------|-------------------------------|---------------------|
| 350" | | |
| Int. | | 1 $\frac{23}{32}$ " |
| Exh. | | 1 $\frac{5}{8}$ " |
| 400" | | |
| Int. & Exh. | | 1 $\frac{7}{8}$ " |

| VALVE SPRINGS | | | |
|---------------|-------------|-----------------|---------------|
| Engine | Free Length | PRESSURE (LBS.) | |
| | | Valve Closed | Valve Open |
| 350" | | | |
| Int. | 2.03" | 76-84@1.70" | 194-206@1.25" |
| Exh. | 1.91" | 76-84@1.61" | 194-206@1.20" |
| 400" | 2.03" | 76-84@1.70" | 194-206@1.25" |

VALVE SPRINGS

Removal — With cylinder head removed, compress valve spring with a suitable spring compressor and remove keepers. Release spring compressor and remove retainer, shield, spring and damper, and shims.

Installation — To install valve springs, reverse removal procedure. Install seal in second groove of valve stem before installing keepers and releasing spring compressor.

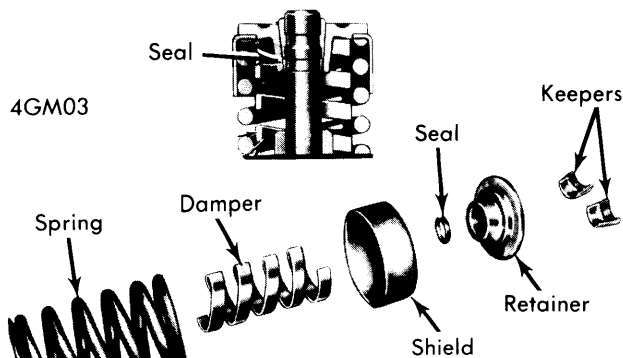

VALVE SPRING ASSEMBLY

ROCKER ARM STUDS

Rocker arm studs that are loose in head or have damaged threads can be replaced with oversize studs. Studs are available .003" and .013" oversize.

Removal — Remove stud using a suitable stud extractor (J-5802-1). Install extractor over stud and tighten nut until stud is pulled from cylinder head.

Installation — Ream hole for oversize studs with a suitable reamer (J-5715 for .003" oversize and J-6036 for .013" oversize). Coat press fit area of stud with hypoid axle grease. Drive rocker stud into place with a suitable driver (J-6880) and a hammer. When driver bottoms out on head, stud is at correct height.

HYDRAULIC VALVE LIFTER ASSEMBLY

Disassembly — Depress plunger in lifter with a push rod and pry out retainer with a small blade screwdriver. Remove push rod seat and metering valve. Remove plunger, ball check valve assembly and plunger spring. Remove ball check valve and spring by prying ball retainer loose with a small blade screwdriver.

Assembly — 1) Thoroughly clean and inspect all components. If any components are worn or damaged, complete lifter must be replaced. Position check ball on small hole in bottom of plunger. Insert check ball spring on seat in ball retainer and position retainer on ball so that spring seats on ball. Using a screwdriver, press plunger into position.

2) Slide lifter body over spring and plunger, lining up oil feed holes. Fill assembly with SAE 10 oil and depress plunger to stop. With plunger depressed, insert a $\frac{1}{16}$ " drift punch into feed holes. Release plunger and refill with SAE 10 oil. Install metering valve, push rod seat and retainer. Depress push rod seat and remove drift punch.

General Motors V8 Engines

350" & 400" V8 ENGINES (Cont.)

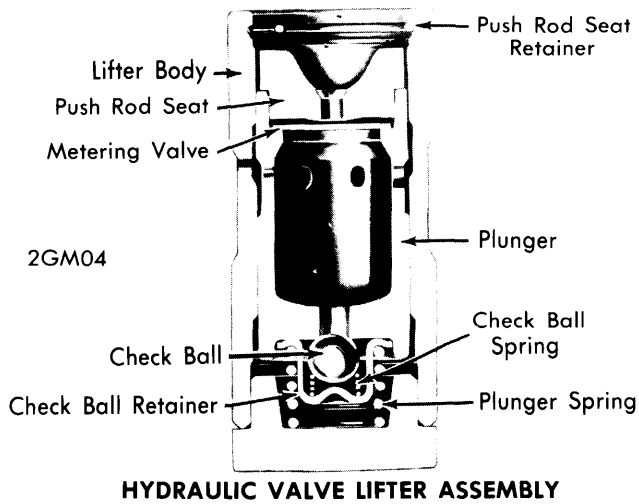

HYDRAULIC VALVE LIFTER ADJUSTMENT

1) Rotate engine until engine is at number 1 firing position. Back off rocker arm adjusting nuts on number 1 intake and exhaust rocker arms until play in push rod is detected. Now tighten rocker arm nuts until play in push rod is just eliminated then tighten adjusting nuts one full turn more. With engine at number 1 firing position, adjust intake valves 1, 2, 5 and 7 and exhaust valves 1, 3, 4 and 8.

2) Rotate engine to number 6 firing position and follow same procedures for adjusting valves. With engine at number 6 firing position, adjust intake valves 3, 4, 6 and 8 and exhaust valves 2, 5, 6 and 7.

| PISTONS, PINS, RINGS | | | | | | |
|----------------------|---------------|----------------|--------------|-------|------------|----------------|
| Engine | PISTONS | PINS | | RINGS | | |
| | Clearance | Piston Fit | ⊙ Rod Fit | Rings | End Gap | Side Clearance |
| 350" | .0007-.0013" | .00015-.00025" | .0008-.0016" | 1 | .010-.020" | .0012-.0032" |
| | | | | 2 | .013-.025" | .0012-.0032" |
| | | | | 3 | .015-.055" | .002-.007" |
| 400" | .0014"-.0027" | .00015-.00025" | .0008-.0016" | 1 | .010-.020" | .0012-.0017" |
| | | | | 2 | .010-.020" | .0012-.0032" |
| | | | | 3 | .015-.055" | .000-.005" |

⊙ — Interference fit.

cylinders are bored, various oversize pistons are available. See oversize piston table for oversize pistons available from manufacturer.

OIL PAN REMOVAL

See *Oil Pan Removal* at end of ENGINE Section.

PISTON & ROD ASSEMBLY

Removal — With oil pan, oil pump and cylinder heads removed, remove any ridge in top of cylinder bore with a suitable ridge reamer. Check connecting rod and cap for identification marks or numbers and identify if necessary. Remove connecting rod cap nuts and rod cap. Push piston and rod assembly up and out of cylinder block. It will be necessary to rotate crankshaft to various positions to facilitate removing piston and rod assemblies.

Installation — Before installing piston and rod assembly, place ring gaps in positions shown in illustration. Place connecting rod in bore with bearing tang slots facing away from camshaft. Compress piston rings with a suitable ring compressor. With rod bearings and crankshaft rod journal lubricated, push piston and rod assembly into position and install rod cap to respective rod. Install and tighten rod nuts.

FITTING PISTONS

1) With piston and rod assemblies removed, wipe cylinder bores clean and measure diameter 2 1/2" below top of cylinder with a micrometer. If cylinder is worn or is tapered more than .005", cylinder must be bored for oversize pistons.

2) If bore is worn or tapered less than .005", cylinder can be cleaned and honed, and .001" oversize pistons installed. If

3) To check fit of rings in cylinder bore, insert ring in cylinder bore and push ring into bore 2" with head of piston. Measure ring end gap with a feeler gauge. Before installing rings on pistons, ensure ring grooves are clean of carbon and inspect grooves for nicks or burrs. Install rings with gaps positioned as shown in illustration.

| Application | Oversize Pistons | Size |
|---------------|------------------|-------|
| 1975 All..... | | .030" |

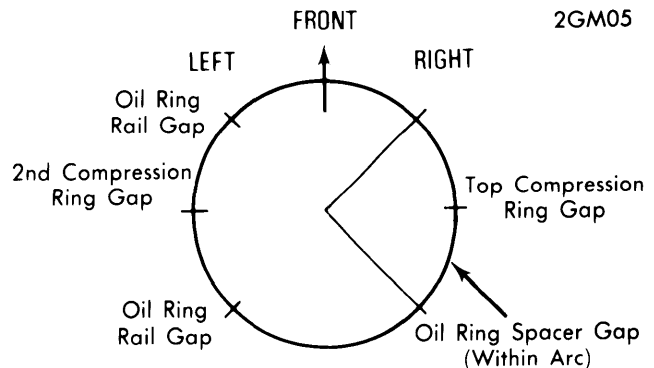

RING GAP LOCATIONS

350" & 400" V8 ENGINES (Cont.)

PISTON PINS

Removal — With piston and rod assembly removed, press out piston pin using a suitable removing and installing tool (J-9510) and an arbor press. Separate piston from connecting rod.

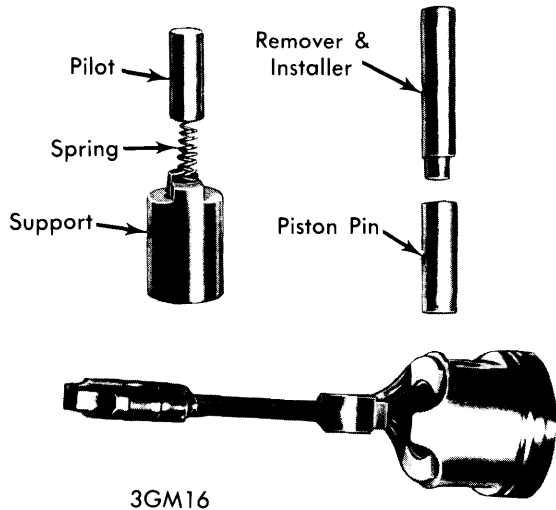

PISTON PIN REMOVAL & INSTALLATION

Installation — Check clearance of piston pin in piston. If clearance exceeds .001" over specified clearance, piston and pin must be replaced. Position piston on rod correctly. See *Piston and Rod Positioning*. Lubricate piston pin and press in using same tools as outlined in removal procedure. Check piston for freedom of movement on piston pin.

PISTON & ROD POSITIONING

Position piston on rod so that bearing tang notch in rod is aligned with side "A" of piston (see illustration) for cylinders 2, 4, 6, and 8 and aligned with side "B" (see illustration) for cylinders 1, 3, 5 and 7.

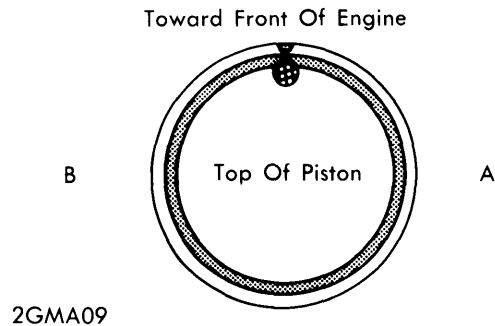

PISTON & ROD POSITIONING

CRANKSHAFT MAIN & CONNECTING ROD BEARINGS

| Engine | MAIN BEARINGS | | | | CONNECTING ROD BEARINGS | | |
|--------|------------------|----------------|----------------|---------------------|-------------------------|--------------|------------|
| | Journal Diam. | Clearance | Thrust Bearing | Crankshaft End Play | Journal Diam. | Clearance | Side Play |
| 350" | ① 2.4484-2.4493" | ③ .0008-.0020" | No. 5 | .002-.006" | 2.199-2.200" | .0013-.0035" | .008-.014" |
| | ② 2.4479-2.4488" | ④ .0011-.0023" | | | | | |
| | | ② .0017-.0033" | | | | | |
| | | | | | | | |
| 400" | ① 2.6484-2.6493" | ③ .0008-.0020" | No. 5 | .006-.010" | 2.199-2.200" | .0013-.0035" | .008-.014" |
| | ② 2.6479-2.6488" | ④ .0011-.0023" | | | | | |
| | | ② .0017-.0033" | | | | | |
| | | | | | | | |

- ① — Journal nos. 1, 2, 3 and 4.
- ② — Journal no. 5.
- ③ — Journal no. 1.
- ④ — Journal nos. 2, 3 & 4.

MAIN & CONNECTING ROD BEARINGS

NOTE — Following procedures are performed with oil pan and oil pump removed.

Connecting Rod Bearings — 1) Mark or identify rod cap to rod before removing rod cap nuts. With rod nuts removed, remove rod cap and bearing. Push up on piston and rod assembly and remove bearing from rod. Inspect bearings for wear or damage and replace as necessary.

2) Check crankshaft rod bearing journal for out-of-round or taper conditions. If crankshaft is out-of-round or tapers more than .001", crankshaft must be removed and ground for undersize bearings.

3) Check bearing clearance using the Plastigage method. If clearance exceeds specifications, a .001" or .002" undersize bearing may be installed to obtain correct clearance. If clearance is still excessive, crankshaft must be removed and ground for undersize bearings. Connecting rod bearings are available .010" and .020" undersize.

4) To install bearings, clean crankshaft journal and bearing surface in rod. Insert bearing halves in rod and cap. Lubricate journal and pull piston and rod assembly down, aligning bearing on journal. Install rod cap noting identification marks and evenly tighten rod nuts.

Main Bearings — 1) Main bearings are selective fit by manufacturer during production. A standard size bearing half may be used in combination with a .001" undersize bearing half to obtain correct clearance. This combination will decrease clearance .0005".

350" & 400" V8 ENGINES (Cont.)

2) If correct clearance could not be obtained during production, a crankshaft with .009" undersize main bearing journals is fitted. A .009" and .010" bearing half combination may be used to obtain correct clearance.

3) If engine is fitted with a crankshaft with .009" undersize main bearing journals, it will be identified by a 9 stamped in left front oil pan rail. Crankshaft can also be identified by a .009" stamped in crankshaft counterweight forward of center main bearing.

4) Main bearings may be removed and replaced with crankshaft still installed in engine. Mark or identify main bearing caps to cylinder block before removing caps. Bearings are removed from cylinder block by inserting a bearing removal and installation tool in oil hole in crankshaft and rotating crankshaft clockwise.

5) Crankshaft clearance, taper or out-of-round conditions can be checked using the Plastigage method. If clearance exceeds specifications, a .001" or .002" undersize bearing may be installed to obtain correct clearance. Both bearing halves must be replaced.

6) If correct clearance cannot be obtained or journal tapers or is out-of-round more than .001", crankshaft must be removed and ground for undersize bearings. Bearings are available .010", .020" and .030" undersize.

7) To install bearings, ensure crankshaft journal and bearing surface in cap and block are clean. Lubricate journal and install bearing in cap. If bearings were removed with crankshaft still installed, use bearing removal and installation tool inserted in crankshaft oil hole to install upper bearing half. Install main cap noting identification marks and evenly tighten main bearing bolts.

THRUST BEARING ALIGNMENT

Pry crankshaft forward as far as possible and check crankshaft end play with a feeler gauge inserted between front of rear main bearing and crankshaft. Replace rear main bearing if end play not to specifications.



CHECKING CRANKSHAFT END PLAY

REAR MAIN BEARING OIL SEAL

Removal - Remove rear main bearing cap and pry out old seal. Remove upper half of seal by tapping end with brass punch until end of seal protrudes enough to be removed with pliers.

Installation - 1) Fabricate installation tool as shown in illustration. Coat seal lips and seal bead of upper seal with motor oil. Keep ends of seal dry of oil and position tool between crankshaft and seal seat in cylinder block. Position seal between tip of tool and crankshaft.

2) Roll seal around crankshaft, using tool as a "shoehorn" to protect seal from sharp corner of seal seat surface. Make sure that oil seal lip is positioned towards front of engine. **NOTE** - Installation tool must remain in position until seal is positioned with both ends flush with block. Remove tool taking care not to remove seal.

3) Install lower half of seal in bearing cap, using tool as a "shoehorn". Feed seal into cap using light pressure with thumb and finger. Install bearing cap with sealant applied to face, taking care to keep sealant off split line.

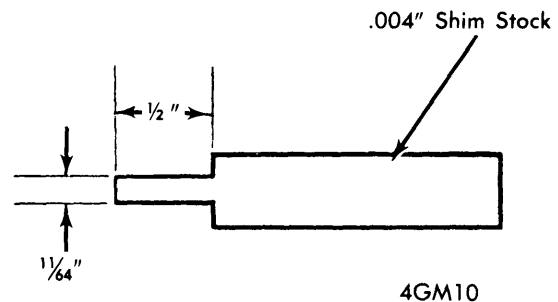

REAR MAIN OIL SEAL INSTALLATION TOOL

ENGINE FRONT COVER

Removal - Remove oil pan as previously outlined. Remove fan belt, fan and pulley. Remove radiator shroud and accessory drive pulley. Remove harmonic balancer pulley bolt (if equipped). Pull off harmonic balancer with a suitable puller (J-23523). Remove water pump and front cover retaining screws. Remove cover and gasket.

Installation - 1) Make sure gasket surface on cover and cylinder block are clean. Using a sharp knife, remove any excess gasket protruding from between oil pan and cylinder block. Apply a 1/8" bead of silicone rubber sealer to oil pan and cylinder block junction and oil pan front lip.

2) Coat front cover gasket with sealer and position on cover. Position cover on cylinder block. Install top four screws and tighten three turns. Install two 1/4 -20x 1/2" screws on each side in lower holes in cover. Install a bead of silicone sealer on bottom of front cover to oil pan seal and install seal.

350" & 400" V8 ENGINES (Cont.)

3) Using a drift punch, align dowel pins in block with holes in cover and alternately tighten screws until cover is pulled into position. Remove two lower 1/4-20x1/2" bolts and install remaining cover screws. Install harmonic balancer using a suitable tool (J-23253). To install remaining components, reverse removal procedures.

FRONT COVER OIL SEAL

With Cover Removed — Pry seal out of cover with a screwdriver. Install new seal with open end of seal toward inside of cover and drive into position with a suitable driver (J-23042) and a hammer. Support cover at seal area before driving in seal.

With Cover Installed — With harmonic balancer removed, pry seal out front of cover. Install seal with open end of seal toward engine and drive into place with a suitable driver (J-23042) and a hammer.

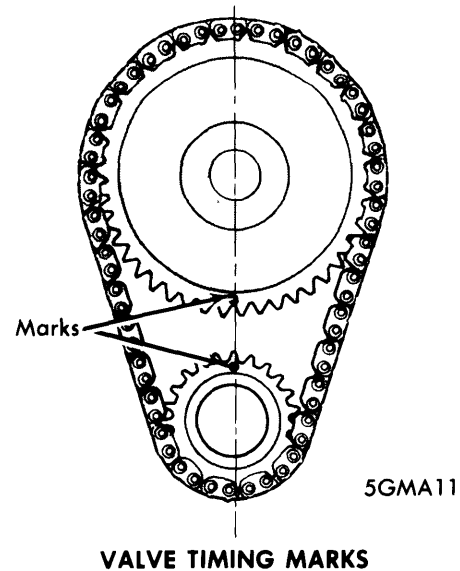

| CAMSHAFT | | | |
|----------|----------------|-----------|-----------|
| Engine | Journal Diam. | Clearance | Lobe Lift |
| 350" | 1.8682-1.8692" | | |
| Int. | | | .2600" |
| Exh. | | | .2733" |
| 400" | 1.9482-1.9492" | | |
| Int. | | | .2235" |
| Exh. | | | .2411" |

TIMING CHAIN & SPROCKETS

Removal — Remove engine front cover as previously outlined. Crank engine over until timing marks on camshaft and crankshaft sprockets are aligned. Remove bolts securing camshaft sprocket to camshaft and pull off sprocket with timing chain. To remove crankshaft sprocket, pull off with a suitable puller (J-5825).

Installation — To install new crankshaft sprocket, pull into place with a bolt or drive into place with a suitable driver and hammer. Install camshaft sprocket and timing chain making sure timing marks on sprockets are aligned (see illustration). Install and tighten sprocket bolts.

CAMSHAFT

Removal — Remove intake manifold, engine front cover and timing chain as previously outlined. Remove valve covers and loosen all rocker arms until push rods can be removed. Remove grille and radiator if necessary. Remove fuel pump and push rod. Screw two bolts into camshaft and withdraw camshaft.

Installation — Lubricate camshaft journals and lobes with motor oil. If a new camshaft is being installed, coat camshaft lobes with Molykote. Position camshaft to align timing marks on sprockets. Install remaining components as previously outlined. Adjust hydraulic valve lifters.

CAMSHAFT BEARINGS

Position number 1 cam bearing oil holes equal distance from 6 o'clock position. Position number 2, 3 and 4 bearings at 5 o'clock from left side of engine and even with bottom of cylinder bore. Position number 5 bearing oil hole at 12 o'clock.

CAM LOBE LIFT

With valve cover removed, remove rocker arm. Mount dial indicator on cylinder head and position indicator stem on a suitable ball socket adapter (J-8520) on push rod. Rotate engine slowly until lifter is on heel of camshaft and set dial indicator to 0. Rotate engine slowly until push rod is at fully raised position. Dial indicator will give total camshaft lobe lift. Lift should be within specifications.

ENGINE OILING

Crankcase Capacity — Capacity is four quarts, add one quart with filter change.

Oil Filter — Replaced every other oil change or more often under dusty or severe conditions.

Oil Pressure — With engine at normal operating temperature, oil pressure should be 40 lbs. at 2000 RPM.

ENGINE OILING SYSTEM

Description — Positive pressure lubrication provided to all main, camshaft, and connecting rod bearings and to all valve lifters and rocker arms. Three horizontal oil galleries located in "V" at center of engine distribute oil under pressure to all parts. See illustration.

General Motors V8 Engines

350" & 400" V8 ENGINES (Cont.)

ENGINE OILING (Cont.)

Valve Lifters — Oil passage from rear camshaft bearing supplies oil to lifter galleries. Both mechanical and hydraulic lifters intersect the gallery. Recess in mechanical lifter permits oil to pass into lower end of push rod. A larger passage in rear camshaft bearing permits more oil pressure for lubrication of hydraulic lifters. Hydraulic lifters contain an inertia valve which opens permitting oil to pass to hollow pushrods.

Rocker Arms and Valve Stems — Oil passes up through hollow pushrods to a hole in upper end that matches hole in rocker arm. Oil sprayed out this hole and across rocker arm lubricates valve stem tip.

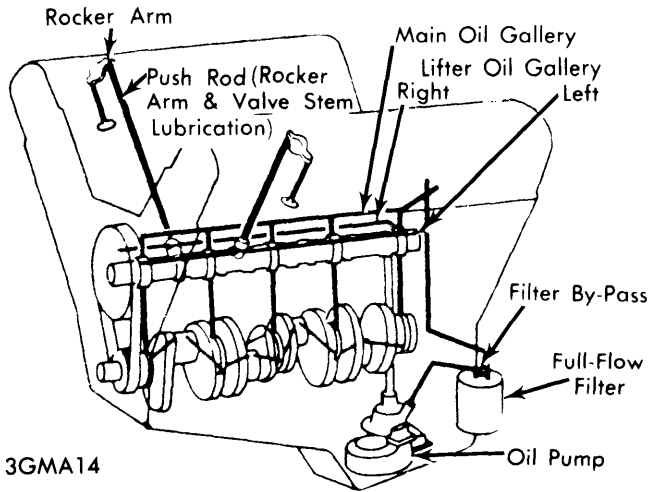

ENGINE OILING SYSTEM

OIL PUMP

Removal — Mark gears so they may be reassembled with same teeth indexing. Do not disturb pickup screen on pipe. Screen is serviced as an assembly. **NOTE** — If pump gears or body are damaged or worn, replacement of entire pump assembly is necessary.

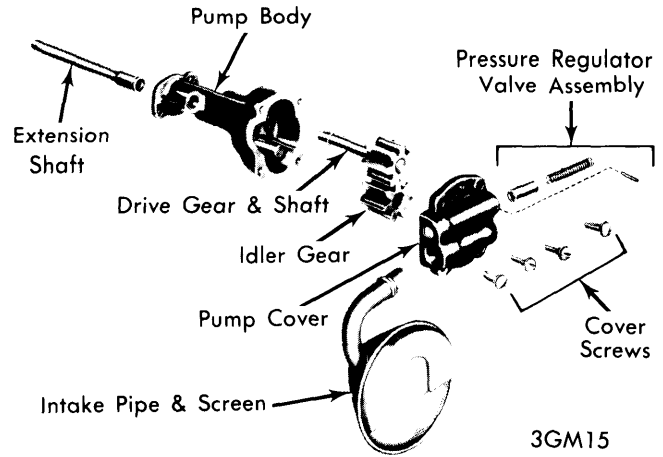

ENGINE OIL PUMP

Installation — Apply sealer to end of pipe and tap in place. Install idler gear in pump body with smooth side of gear towards cover opening. **NOTE** — Bottom of screen must be parallel with bottom of pan.

TIGHTENING SPECIFICATIONS

| Application | Ft. Lbs. |
|--------------------------|----------|
| Cylinder Head | 65 |
| Main Bearing Caps | ① 70 |
| Connecting Rod Nuts..... | 45 |
| Camshaft Sprocket | 20 |
| Intake Manifold | 30 |
| Exhaust Manifold..... | ② 20 |
| Water Pump | 30 |
| Flywheel | 60 |
| Harmonic Balancer | 60 |
| Oil Pump..... | 65 |

- ① — Outer bolts on 4 bolt caps 65 ft. lbs.
- ② — Two center bolts on 350" engine 30 ft. lbs.