

GENERAL MOTORS 12 1/4" RING GEAR

Chevrolet P-30
GMC P-3500

DESCRIPTION

The axle has a banjo-type housing with a removeable carrier. The drive pinion is straddle mounted on removeable carrier. There is no adjustment for drive pinion depth or bearing preload. The preload on the differential side bearings is set by adjusting nuts on which the bearing cups rest. The differential has a two-piece case and four differential pinion gears.

AXLE RATIO & IDENTIFICATION

The 12 1/4" ring gear axle assembly is the only one on General Motors vehicles that has a removeable carrier. The axle ratio can be determined by dividing number of ring gear teeth by number of drive pinion teeth.

REMOVAL & INSTALLATION

AXLE SHAFTS

Remove axle shaft hub cap and install slide hammer into hole on axle shaft flange. Pull shaft straight out of housing. To install, reverse removal procedure, using a new gasket on hub cap, and making sure axle flange splines index into wheel hub splines.

WHEEL HUB & SEAL

Remove axle shaft, then remove lock nut retainer, lock nut, adjusting nut and thrust washer from axle housing. Pull hub and drum assembly straight off axle housing, using care not to drop bearing inner race and roller assembly. Pry old seal from wheel hub, using care not to damage bore surface. Thoroughly clean seal contact area, then pack cavity between seal lips with high melting point wheel bearing lubricant. Position seal in hub bore, then carefully press seal into hub using suitable tool (J-22354) until seal is flush with edge of hub. Install hub onto axle housing and install axle shaft.

WHEEL BEARINGS

1) With wheel hub removed from vehicle, place suitable length of 1/2" bar stock behind INNER bearing cup and index in notches in hub. Using press tool against bar stock, press out cup.

2) Using suitable tool (J-22380), remove OUTER bearing retaining ring. Drive against axle shaft spacer, using splined flange end cut from an old axle shaft to remove OUTER bearing cup.

3) Place axle shaft spacer in hub, then insert outer bearing, with larger O.D. toward outside of hub. Position outer bearing cup in hub and press in until squarely seated. Install bearing retainer, then press outer cup into contact with retainer ring.

4) Using suitable tool (J-8093), press inner bearing cup into hub bore until seated against shoulder. Install new hub oil seal.

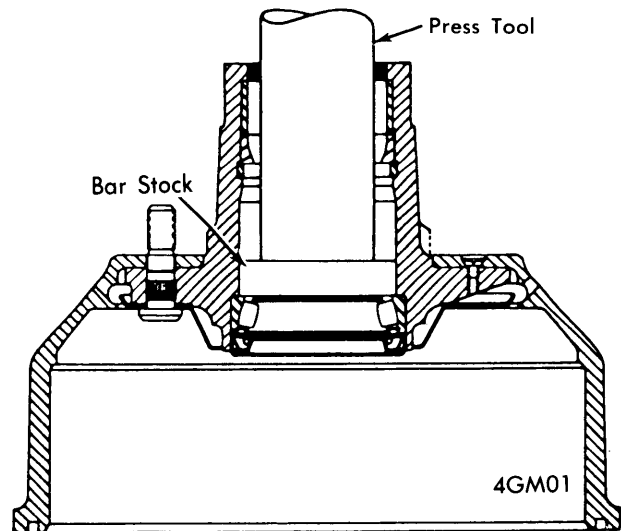

INNER BEARING CUP REMOVAL

5) Place hub assembly onto axle housing and install adjusting nut. Tighten adjusting nut to 75-100 ft. lbs., then back nut off 1/8 turn. Install tanged retainer against nut and align adjusting nut such that short tang of retainer engages nearest slot in nut. Install outer lock nut and tighten to 250 ft. lbs. Bend long tang of retainer to engage slot in lock nut, then install axle shaft.

PINION FLANGE & SEAL

Disconnect propeller shaft and tie out of way, then scribe a line down pinion nut, pinion stem and pinion flange for reassembly reference. Remove pinion nut and pull pinion flange from stem, then remove oil seal retainer bolts and remove retainer from carrier. Pry old seal from bore, using care not to damage machined surfaces. Clean area thoroughly, then pack cavity between seal lips with high melting point bearing lubricant. Place seal into bore, then drive seal in until it bottoms against shoulder in retainer. Install retainer to carrier; then install pinion flange, pinion nut and propeller shaft.

DIFFERENTIAL CARRIER

Drain lubricant, then remove axle shafts and axle housing cover. Remove trunnion bearing "U" bolts and split universal joint. Tie propeller shaft out of way and remove carrier-to-housing attaching bolts. Support carrier on suitable lift and remove from axle housing. To install, reverse removal procedure.

OVERHAUL

DISASSEMBLY

1) With carrier assembly mounted in suitable holding device, loosen thrust pad lock nut and remove thrust pad. Remove differential adjusting nut locks and bearing cap bolts. Mark bearing caps and carrier for reassembly reference, then remove adjusting nuts and bearing caps. Remove differential and ring gear assembly from carrier.
CAUTION — Do not attempt to pry cap from carrier, as this may damage machined face of cap.

GENERAL MOTORS 12 1/4" RING GEAR (Cont.)

2) Remove pinion seal retainer bolts, then remove pinion gear and bearing assembly from carrier. Remove pinion nut, pinion flange and pinion seal retainer from pinion gear, then press bearings from gear.

3) Mark differential case halves for reassembly reference, then remove ring gear and differential side bearings. Split case halves and remove differential side gears, differential spider and pinion gears, and thrust washers.

REASSEMBLY & ADJUSTMENT

Drive Pinion — Pack cavity between pinion seal lips with high melting point bearing lubricant and install seal into pinion seal retainer. Install pinion rear bearing assembly onto pinion shaft such that chamfered side of inner race seats against shoulder, then install bearing lock ring. Install pinion front bearing onto shaft such that extended portion of inner race is toward pinion head. Place oil seal retainer onto pinion shaft, then install pinion flange and nut. Place pinion gear and bearing assembly into carrier and install pinion seal retainer attaching bolts.

NOTE — Pinion depth and pinion bearing preload adjustments are not required for this axle.

Case Assembly—1) Lubricate differential pinion gears, side gears and thrust washers, then place pinion gears and thrust washers on differential spider. Install side gears and spider assembly into left half of differential case, then assemble two halves of case, making sure alignment marks on both halves are together.

2) Install two guide pins in ring gear, directly opposite each other. Start guide pins through holes in case flange and tap ring gear lightly with soft face hammer until ring gear attaching bolts can be started. Tighten bolts evenly until ring gear is flush with case flange. Remove two guide pins and tighten all ring gear bolts alternately and evenly.

Backlash & Final Assembly—1) Install differential case assembly, bearing adjusting nuts and side bearing caps into carrier. With bearing caps loosened to permit turning of adjusting nuts, adjust bearings to remove all backlash from ring gear and pinion.

2) Loosen left adjusting nut one or two notches to a locking position, then tighten right adjusting nut to force differential against left adjusting nut. Back off right adjusting nut slightly, then retighten snugly against bearing. Tighten right nut additional one or two notches to a locking position.

NOTE — This adjustment provides for proper preload of differential side bearings.

3) Mount dial indicator to carrier and check backlash at four locations around ring gear. Adjust backlash to specifications and tighten bearing cap bolts. Install bearing adjusting nut locks and check tooth contact pattern. Install ring gear thrust pad and tighten until pad just touches back face of ring gear while rotating gear. Back off thrust pad screw 1/12 turn and tighten lock nut.

CAUTION — If one adjusting nut is loosened the other nut must be tightened an **EQUAL AMOUNT** to maintain side bearing preload.

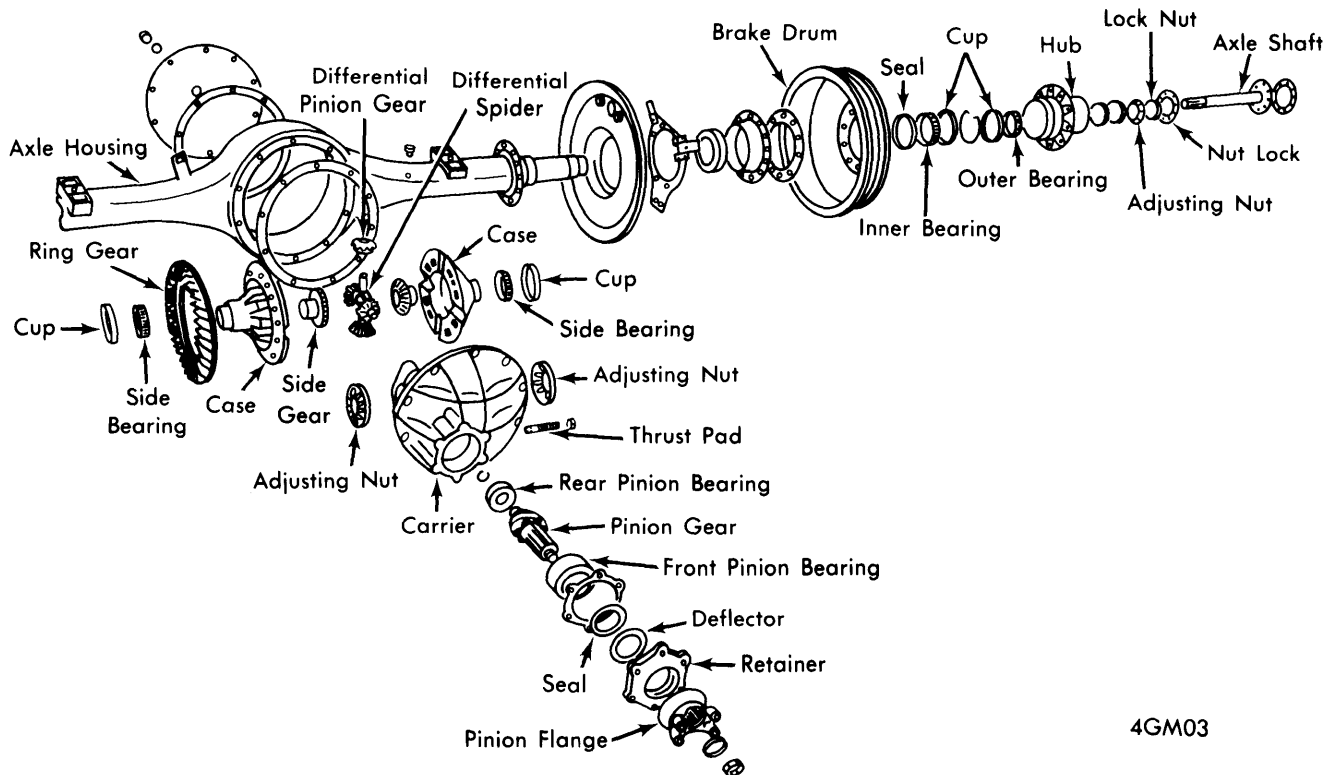

4GM03

GENERAL MOTORS 12 1/4" RING GEAR AXLE ASSEMBLY

Drive Axles

GENERAL MOTORS 12 1/4" RING GEAR (Cont.)

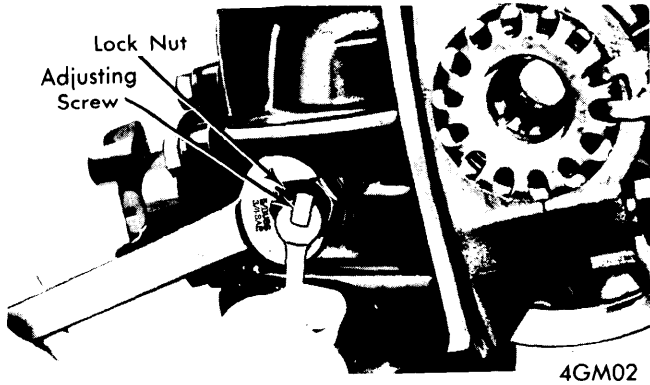

RING GEAR THRUST PAD ADJUSTMENT

AXLE ASSEMBLY SPECIFICATIONS

Ring Gear Backlash	
Preferred005-.008"
Acceptable003-.012"
Thrust Pad Clearance005-.007"

TIGHTENING SPECIFICATIONS

Application	Torque (Ft. Lbs.)
Ring Gear	105
Side Bearing Cap	205
Drive Pinion Nut	220
Differential Carrier	85
Differential Bearing Adjusting Lock	15
Pinion Seal Retainer	165
Thrust Pad Lock Nut	135