

AMC/JEEP 8 7/8" RING GEAR

Jeep (CJ Models)

DESCRIPTION

The AMC/Jeep 8 7/8" ring gear axle assembly is the hypoid gear type with integral carrier housing. Unit is used as rear drive axle on all CJ models. Unit is semi-floating axle type with tapered axle shafts. Pinion bearing preload is adjusted with a collapsible spacer. Side bearing preload is adjusted by varying shim thickness. A removable housing cover allows access to differential for inspection or minor servicing without removing axle assembly.

AXLE RATIO & IDENTIFICATION

Axle ratio is identified by a code letter stamped in cast housing boss on right side of cover adjacent to dowel hole. Unit can also be identified from other units by number of cover bolts. The AMC/Jeep axle has a 12 hole cover, while other axle units have 10 hole covers. Models with Trac-Lok differential have a tag secured to cover by one of the cover bolts. Tag indicates that only Jeep Trac-Lok differential lubricant be used.

Axle Ratio Identification

Code	Ratio
A (Standard)	3.54:1
L (Standard)	4.09:1
M (Trac-Lok)	3.54:1
N (Trac-Lok)	4.09:1

REMOVAL & INSTALLATION

AXLE HUB

Removal — Remove dust cap, nut and washer. Raise vehicle and remove wheel and tire. Remove drum retaining screws and remove drum. Using a suitable puller (J-25109) remove hub. Inspect hub for loose or damaged wheel studs. Check keyway and tapered center bore for wear or cracks and replace hub if necessary.

NOTE — Installation procedures for a new hub and an old hub will differ. If axle shaft is replaced, hub must also be replaced, but a new hub can be installed on an old axle shaft.

Installation (Original Hub) — Align axle key and hub keyway. Slide hub onto axle shaft as far as possible. Install nut and washer, drum, retaining screws, and wheel and tire. Lower vehicle and tighten nut to 250 ft. lbs. Tighten nut to align cotter key hole, DO NOT back nut off.

Installation (New Hub) — 1) Align axle key and hub keyway. Slide hub onto axle shaft as far as possible. Install two lubricated thrust washers and axle shaft nut. Install drum, retaining screws, and wheel and tire. Lower vehicle.

2) Tighten axle shaft nut until distance from outer hub face to end of axle is 1.30". **NOTE** — Pressing hub on at this dimension is necessary to form hub serrations correctly. Remove axle shaft nut and one washer. Install nut and tighten to 250 ft. lbs. Tighten nut to align cotter key hole, DO NOT back off nut.

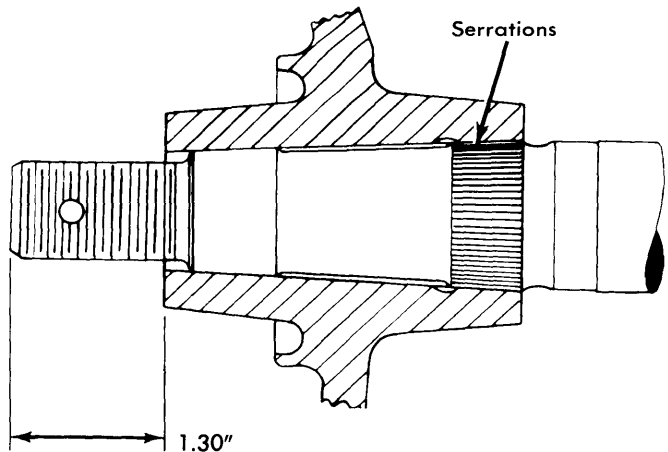

Fig. 1 View Showing Hub Installation Measurement

AXLE SHAFTS & BEARINGS

Removal — Remove axle hub as previously outlined. Disconnect parking brake cable at equalizer, and brake line at wheel cylinder. Remove backing plate, oil seal, and shims from axle shaft. **NOTE** — If both axles are removed, keep shims separated as axle shaft end play is adjusted on left side only. Using a suitable puller (J-2498) remove axle shaft. Remove and discard inner seal. Bearing cone is press fit on axle shaft and must be removed using an arbor press and suitable mandrels.

Installation — 1) Press new axle bearing onto shaft with small diameter of cone toward outer end of shaft. Coat inner axle shaft seal with a light coat of oil. **NOTE** — Tapered axle shaft bearings have no provision for lubrication and should be packed with a good wheel bearing lubricant before installation. Coat outer surface of metal retainer with nonhardening sealer. Install inner seal in axle housing using a suitable installer (J-21788).

2) Place axle shaft in housing and align splined end with differential gears. Install outer bearing cup. Coat backing plate with sealer at mounting area. Install original shims, oil seal assembly, and backing plate. Tighten backing plate bolts to 35 ft. lbs. Oil seal and retainer are located on outside of backing plate. If left axle was removed, end play must be adjusted.

3) To adjust end play, remove left axle hub if not previously removed. Strike ends of both axles with a lead hammer to seat bearings. Attach a suitable tool and dial indicator to left axle. Move axles back and forth to measure end play. End play should be .004-.008" with .006" recommended. Add shims to increase end play and remove shims to decrease end play. Install hub and drum as previously outlined. Adjust brakes and bleed brake hydraulic system.

PINION FLANGE & SEAL

Removal — Raise and support vehicle and remove both rear wheels and tires, and brake drums. Disconnect propeller shaft from flange. Mark propeller shaft position with flange. Connect an INCH Lb. torque wrench to flange nut. Rotate several times and measure torque required to turn pinion.

Drive Axles

AMC/JEEP 8 7/8" RING GEAR (Cont.)

Record reading for assembly. Hold flange and remove nut. Mark position of flange on drive pinion. Discard pinion nut. Using a suitable puller, remove flange. Pry out old seal and discard.

Installation — Coat seal lip with axle lubricant before installing. Install seal using a suitable installer tool (J-22661). Align drive pinion shaft and flange marks and install flange on drive pinion. Tighten nut only enough to remove end play. Check torque required to turn drive pinion. Refer to reading recorded during flange removal. Tighten nut enough to exceed recorded reading by 5 INCH Lbs. Repeat these steps until desired nut torque is obtained. **CAUTION** — Do Not loosen and retighten nut. Do Not overtighten nut, if correct torque is exceeded, a new collapsible spacer must be installed and drive pinion preload must be reset. Install propeller shaft aligning marks. Install brake drums and wheels and tires.

AXLE ASSEMBLY

Removal — Raise and support vehicle forward of rear springs. Remove wheels and tires. Mark propeller shaft position with flange and disconnect propeller shaft. Disconnect shock absorbers and brake line at "T" fitting. Plug open ends of lines to prevent dirt entering system. Disconnect parking brake cable at equalizer. Support axle housing with a floor

jack. Remove "U" bolts at spring. If vehicle has springs mounted below axles, disconnect shackle bolts and lower spring from axle. Slide axle housing out from under vehicle.

Installation — To install axle assembly, reverse removal procedure. Bleed brake hydraulic system and check axle lubricant level.

OVERHAUL

DISASSEMBLY

NOTE — It is not necessary to remove complete axle assembly from vehicle for overhaul.

1) Remove axle shaft dust caps and retaining nuts. Raise and support vehicle. Remove axle housing cover and drain lubricant. Remove axle hubs as previously outlined. Mark differential side bearing caps with a center punch for reassembly. Loosen bearing cap bolts until they are retained by just a few threads, then pull bearing cap back on bolts. This will prevent differential from falling out. Pry differential loose in housing. Now remove bearing caps and differential. Secure bearing shims to their respective bearing caps and cups.

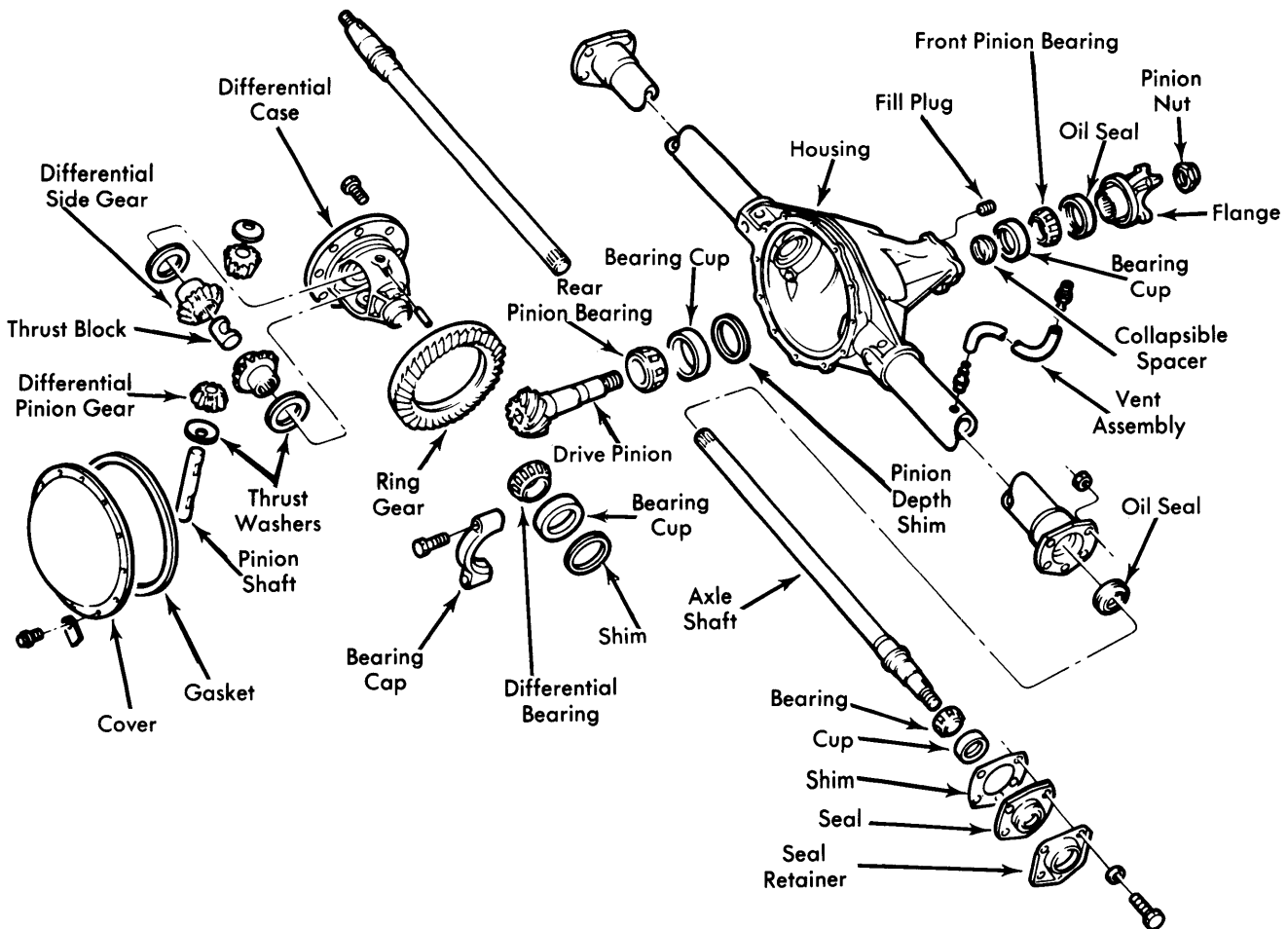

Fig. 2 Exploded View of Drive Axle Assembly

AMC/JEEP 8 7/8" RING GEAR (Cont.)

2) Use a suitable puller to remove side bearings from differential. Make sure puller pulls against bearing cone and not bearing cage or rollers. Remove ring gear retaining bolts and tap ring gear off differential using a brass hammer. Drive out pinion shaft lock pin using a drift punch. Now drive out pinion shaft using a punch. With shaft removed, withdraw thrust block. Roll pinion gears around on side gears until they can be removed. Now remove side gears and thrust washers.

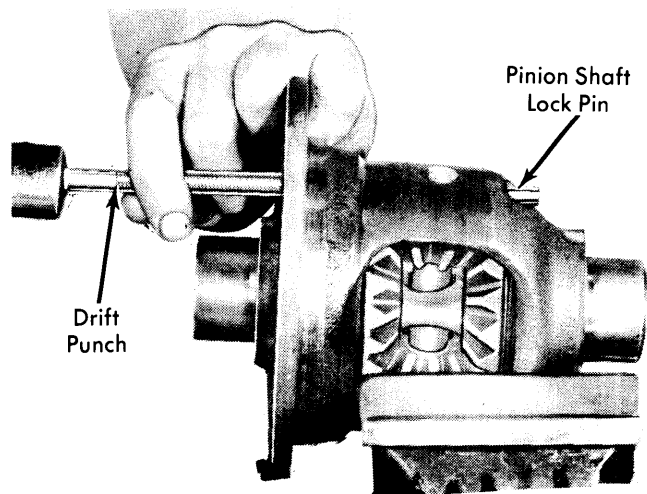

Fig. 3 View Showing Removal Procedure for Pinion Shaft Lock Pin

3) With propeller shaft removed, hold flange with a suitable tool and remove flange retaining nut. Remove flange using a suitable puller. Install housing cover with two bolts. Remove pinion seal. Strike end of drive pinion with a soft mallet. This will unseat front bearing cone from gear. Remove bearing cone. Remove and discard collapsible spacer. Remove housing cover, drive pinion, and rear bearing. Remove front and rear bearing cups using a slide hammer and a suitable adapter. Pinion depth shims are behind rear bearing cone. Secure shims to cone for reassembly reference.

CLEANING & INSPECTION

Clean all components in a suitable solvent. Allow bearings to air dry. Inspect all machined surfaces for smoothness or raised edges. Inspect all bearings and cups for wear or pitting and replace as necessary. Inspect all gear teeth for wear or chipping and replace as necessary. Inspect all splined components for wear or damage and replace as necessary.

ASSEMBLY

Drive Pinion — Press bearing on pinion gear shaft with large diameter of roller cage toward gear. Clean bearing bores in housing, then place shim in rear bearing bore and install rear bearing cup. *NOTE* — When a new gear set is being installed, use original depth shim as a starting point. Chamfered side of shim must be installed to bottom side of rear bearing cup bore. Center shim to prevent tipping bearing cup. Install front bearing cup into housing and install drive pinion through rear bearing cup. Now install front bearing, rear yoke, and original pinion nut. Tighten nut just enough to remove bearing end play. *NOTE* — A new nut and collapsible spacer are not installed at this time as drive pinion will be removed after depth measurement.

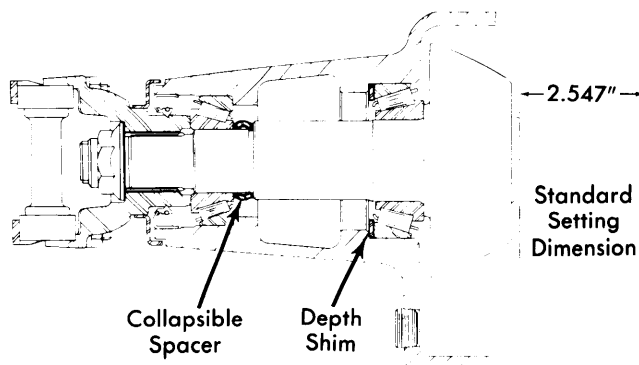

Fig. 4 Sectional View Showing Pinion Depth, Shim Location & Collapsible Spacer Location

Drive Pinion Depth — 1) Observe numbers painted on drive pinion and ring gear. First number on pinion must match number on ring gear. *NOTE* — If numbers do not match, gear set is not a matched set and should not be installed. Second number on pinion is pinion depth variance. If number is preceded by a plus sign, add that number to standard pinion depth. If number is preceded by a minus sign, subtract that number from standard pinion depth. Standard pinion depth for this axle assembly is 2.547". Result of addition or subtraction will be desired pinion depth. Record figure for future reference.

2) Mount gauge arbor tool J-5223-4 and discs J-5223-23 in bearing cup bores in axle housing. Install bearing caps over discs, tighten securely but not to specified torque. Position gauge block J-5223-20 on end face of drive pinion with clamp bar and screw J-5223-24. Loosen thumbscrew in end of gauge block and allow spring loaded plunger to contact arbor. Tighten thumbscrew, taking care not to disturb position of plunger. Remove gauge block and measure distance from end of anvil to top of plunger head using a two to three inch micrometer. Record this measured pinion depth for future reference.

3) Remove gauging tools, drive pinion and rear bearing cup. Remove drive pinion depth shim and measure thickness. Add shim thickness to measured pinion depth. From this total subtract desired pinion depth. This result represents correct shim thickness to be installed. *NOTE* — Replacement gears with a pinion variance of more than .009" should be returned for replacement. Install correct thickness shim in rear bearing bore and install rear bearing cup.

Drive Pinion Bearing Preload — Install collapsible spacer and front bearing on drive pinion, then install oil seal, rear flange and nut. Tighten pinion nut only enough to remove bearing end play. Gradually tighten nut to collapse spacer and preload bearings. *CAUTION* — Do Not overtighten. Use an INCH Lb. torque wrench and measure torque required to turn drive pinion. If preload torque is less than desired, tighten pinion nut slightly and recheck preload. Continue this procedure until desired preload is obtained. *CAUTION* — Do Not exceed preload torque. Do Not back nut off to lessen preload. If preload torque is exceeded, replace collapsible spacer and adjust preload to correct torque.

AMC/JEEP 8 7/8" RING GEAR (Cont.)

Assembling Differential Carrier – 1) Using suitable tools, install differential bearings onto case. Install thrust washers on differential gears (oil pocket side toward gear), then install gears into bores in differential case. Install thrust washers behind differential pinion gears, then mesh gears with differential gears so holes are opposite and in line with each other. Roll gears around until differential pinion gear holes are aligned with shaft holes in case.

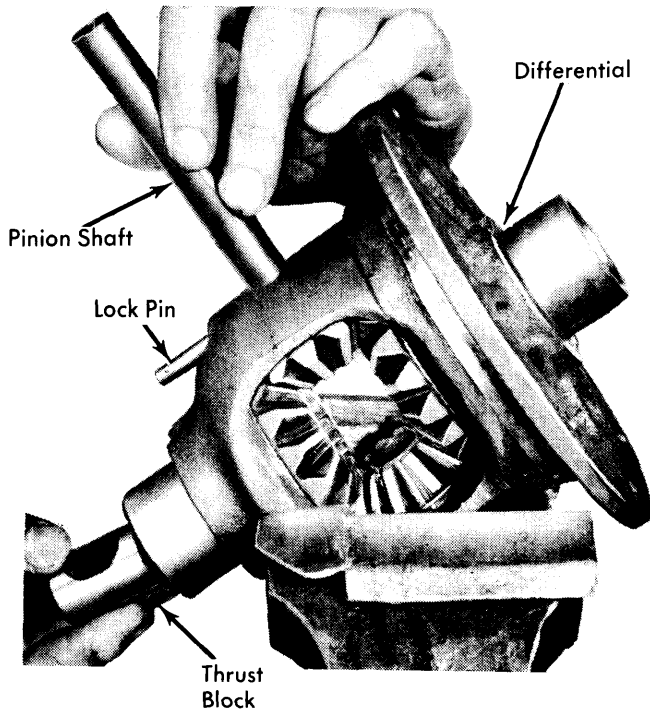

Fig. 5 Installing Pinion Shaft & Thrust Block

2) Install thrust block through a differential gear, aligning hole in block with pinion shaft holes. Install pinion shaft, with lock pin hole in shaft aligned with lock pin hole in case. Measure any existing clearance between differential gears and case, using two feeler gauges on opposite sides of one gear. Clearance should be zero.

Adjusting Differential Bearings – 1) Place bearing cup over each differential bearing, then install differential case assembly in axle housing. As a starting point, install an .080" shim on each side. Install bearing caps and tighten bolts finger tight. Mount a dial indicator to housing so that plunger contacts ring gear mounting flange on differential. Using two screwdrivers, pry between shims and housing. Pry assembly to one side, zero indicator, then pry assembly to opposite side and read indicator. **NOTE** – Do Not read or zero indicator while prying.

2) The amount read on indicator is amount of shim to be added to arrive at a no preload and no end play condition. Shims are available in thicknesses ranging from .080 to .110" in .002" increments. With all side play eliminated, check ring gear mounting flange for runout. Runout should not exceed .002". Remove differential case from housing and retain shims used to eliminate side play.

Ring Gear Installation – Place ring gear on differential housing case and install retaining bolts. Two bolts installed in opposite holes may be used to pull ring gear into place. Tighten bolts to specification.

Backlash Adjustment – Install differential assembly in housing using shims selected to remove side play. Tighten bearing cap screws to 87 ft. lbs. Attach a dial indicator to housing so that indicator plunger contacts drive side of a tooth on ring gear and is at a right angle to it. Rock ring gear and note movement on dial indicator. Backlash should be .005-.009", with .008" desired. To increase backlash, install a thinner shim on ring gear side. To decrease backlash, reverse procedure, however do not change total thickness of shims.

Differential Bearing Preload – 1) Differentials bearings are preloaded by increasing each shim thickness by .004". Install differential bearing shims in axle housing bearing bores. Assemble bearing cups on bearings (cups should completely cover rollers), then position differential so that bearings just start in axle housing bearing bores. Keep assembly square in housing and push in as far as possible. Using a soft hammer, tap outer edge of bearing cups until seated in housing. **CAUTION** – Do Not distort shims by hammering them into housing.

2) Install bearing caps, aligning marks made at disassembly, then install and tighten bolts. Preloading differential bearings may change backlash setting, therefore recheck backlash and correct as necessary. After all adjustments have been made, make a gear tooth pattern check to insure correct assembly. Install propeller shaft, axle shafts, bearings, seals, brake backing plate, hubs and drums, reversing disassembly procedures. Fill rear axle with suitable lubricant.

AXLE ASSEMBLY SPECIFICATIONS

Axle Shaft End Play004-.008"
Pinion Bearing Preload	17-18 INCH Lbs.
Differential Bearing Preload (Shims)008"
Backlash005-.009"
Pinion Gear Depth (Std. Setting)	2.547"

TIGHTENING SPECIFICATIONS

Application	Ft. Lbs.
Differential Bearing Cap Bolts	87
Ring Gear Bolts.....	105
Backing Plate Bolts.....	32
Rear Wheel Hub-to-Axle Nut.....	250 (Min.)
"U" Joint Bolt Clamp.....	13