

Positive Traction Differentials

FORD MOTOR CO. TRACTION-LOK

Bronco
E-100 & E-150
F-100 & F-150

DESCRIPTION

Traction-Lok positive traction differential employs multiple disc clutch to control differential action. Side gear mounting shims, friction discs, composite plate, clutch hub and guides are housed in differential cover. Located in differential case, between side gears, is one-piece preload plate and block assembly and four calibrated preload springs which apply an initial force to clutch pack. Additional clutch capacity is derived from side gear thrust loads. Traction-Lok differential can have either two or four differential pinion gears.

AXLE RATIO & IDENTIFICATION

See *Ford Motor Co. Separate Housing in this Section.*

LUBRICATION

Check level of lubricant every 5,000 miles or 5 months. Manufacturer recommends no specific drain and refill interval. Use only Ford Hypoid Gear Lubricant (C9AZ-19580-A) or equivalent.

TESTING ON VEHICLE

Raise one wheel (opposite wheel firmly on ground) and install suitable adapter and torque wrench to wheel mounting studs. With transmission in Neutral, note torque required to keep wheel rotating through several revolutions (disregard initial starting torque). Torque should be at least 40 ft. lbs.

REMOVAL & INSTALLATION

Same procedure is used to remove and install Traction-Lok differential as conventional differential. See *Ford Motor Co. Separate Housing in this Section.*

OVERHAUL

DISASSEMBLY

1) Press differential bearings from journals on case. Remove ring gear attaching bolts and tap gear from case using a soft-faced hammer. Place differential assembly in a suitable press to load case halves so preload of springs is overcome (approximately 1500 lbs.). If press not available, two $\frac{7}{16}$ " bolts and nuts can be used in ring gear mounting holes (one on each side) to compress case halves and overcome preload tension.

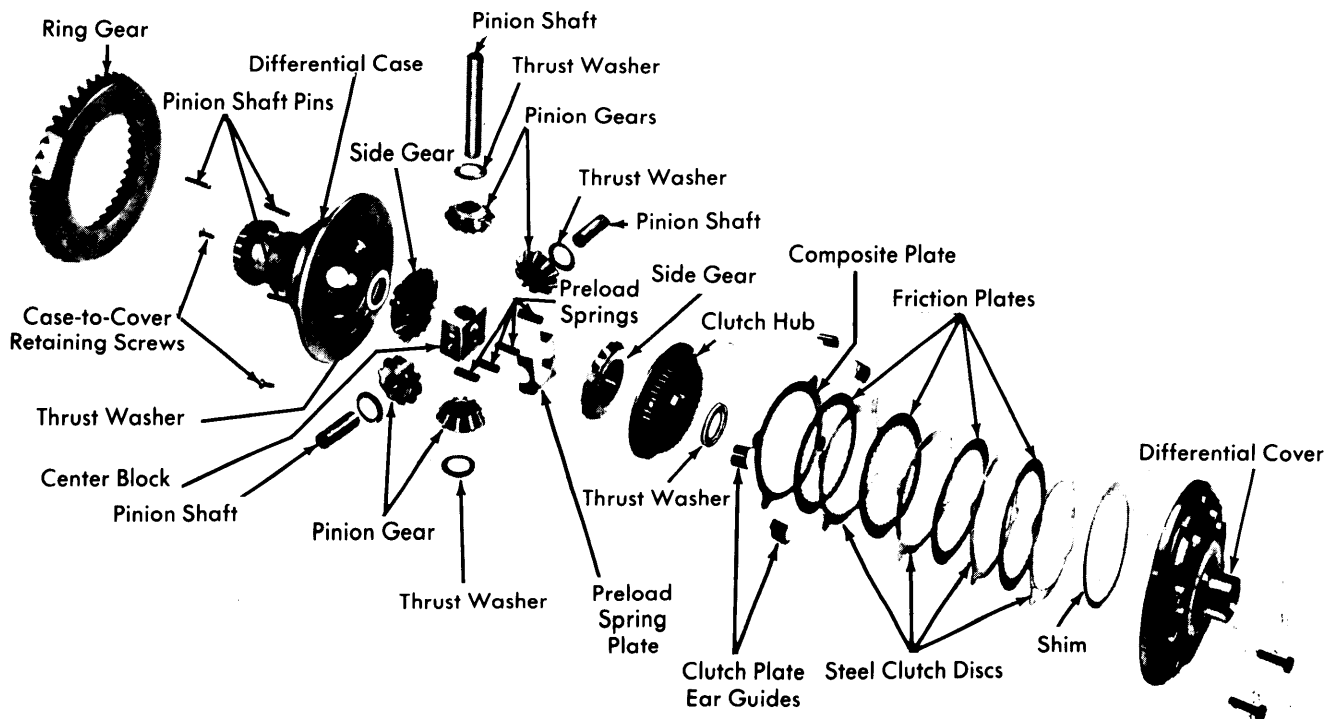

Fig. 1 Exploded View of Typical Ford Motor Co. Traction-Lok Differential Assembly (Four Gear Differential Shown)

FORD MOTOR CO. TRACTION-LOK (Cont.)

2) With case under pressure, loosen two-case-to-cover retaining screws until one or two threads of each remain engaged. Release pressure, tap on cover to spring it loose, then remove two screws. With cover facing down, lift off case, remove preload spring plate and four preload springs.

3) From cover, remove side gear, four clutch plate ear guides, clutch hub, friction plates, steel clutch discs and shims. Using a drift, drive out pinion shaft lock pins from case. Drive long pinion shaft from case, working from end opposite lock pin hole. Remove two short pinion shafts, working from center outward. Lift out thrust block, then remove pinion gears, thrust washers, side gear and side gear thrust washer.

INSPECTION

Inspect clutch plates for unevenness or wear. Dog-eared plates must be free of burrs, nicks or scratches. Inspect internally splined clutch plates for condition of bond, bonding material and wear. Replace bonded plates if thickness less than .085", or if badly worn. Inspect all thrust surfaces and hubs for wear.

REASSEMBLY

1) Lubricate all parts with hypoid gear lubricant prior to assembly. Mount differential case in soft-jawed vise and place a side gear thrust washer and a side gear into counterbore in

case. Install pinion thrust washers and place pinion gears on side gear, aligning holes in washers and gears with holes in case. Install center block so holes in block are aligned with holes in pinion gears and case.

2) Using a brass drift, drive pinion shafts into position from outside of case, making sure lock pin holes in shafts are aligned with corresponding holes in case. Install shaft lock pins, making sure pinion and side gears move freely. Place four preload springs in holes provided in center block. Position preload plate over springs, making sure springs are properly seated. Preload plate straddles center block over its narrower, or machined, width.

3) Mount differential cover in soft-jawed vise. Insert shim(s) of .050" total thickness in cover cavity. Install composite plate on back side of clutch hub with friction material against hub. Install friction plates and steel discs alternately, beginning with friction plate and ending with steel disc, onto hub. *NOTE — When new plates are used, soak in hypoid gear lubricant for 30 minutes before installation.*

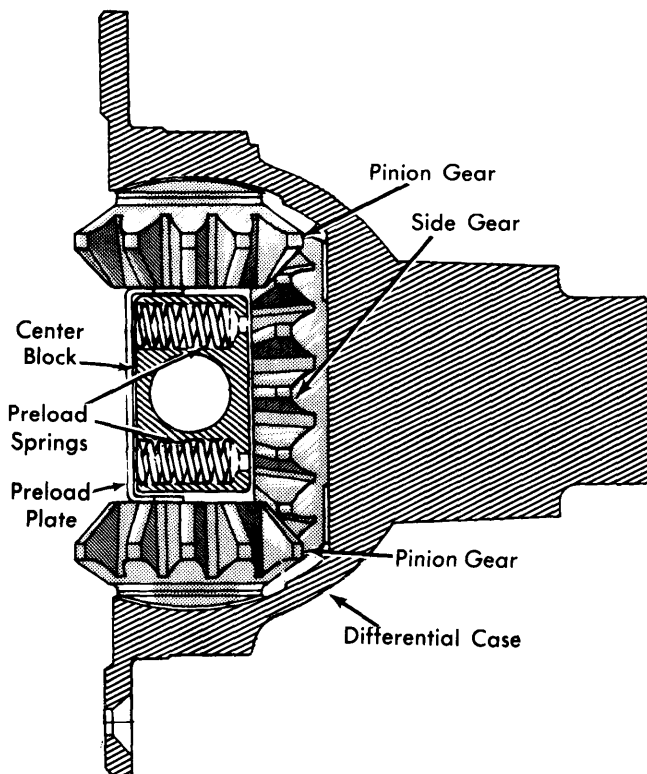

Fig. 2 Sectional View Showing Center Block Installation

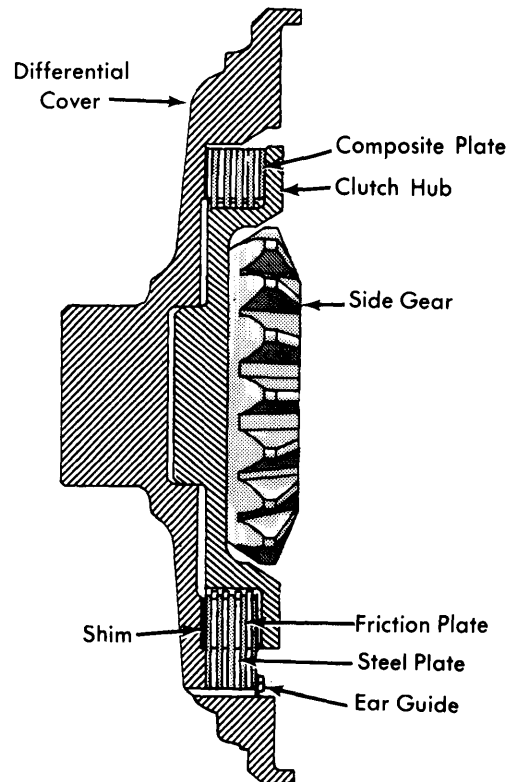

Fig. 3 Sectional View Showing Clutch Pack Installation

4) Place clutch hub with clutch plate into clutch gear cavities in differential cover, making sure splines on last friction plate are engaged on hub. Using a $\frac{5}{8} \times 2 \frac{1}{2}$ " bolt, compress clutch pack and place shim template tool (T68P-4946-A) in clutch hub. Some clearance should be observed between shim tool and cover-to-case mating surface. Using a feeler gauge, measure clearance.

Positive Traction Differentials

FORD MOTOR CO. TRACTION-LOK (Cont.)

Shim Pack Thickness		
Gauge Reading	Correction	Total Shims
.001-.002"	None	.050"
.003-.007"	.005"	.045"
.008-.012"	.010"	.040"
.013-.017"	.015"	.035"
.018-.022"	.020"	.030"
.023-.027"	.025"	.025"
.028-.032"	.030"	.020"
.033-.037"	.035"	.015"
.038-.042"	.040"	.010"
.043-.047"	.045"	.005"
.048-.050"	.050"	None

5) Refer to shim pack thickness chart to determine correct amount of shims to subtract from .050" shim pack originally installed. *NOTE* — In order to correctly select proper shim, template tool must be used. Install selected shim in cover cavity and reinstall internal components as before.

6) Install four steel clutch ear guides and side gear. Place both assemblies in press, force both halves together and install cover-to-case screws. Install ring gear and ring gear attaching bolts and tighten to 65-80 ft. lbs. Check torque required to turn one side gear while other side gear held stationary as in "Testing On Vehicle".

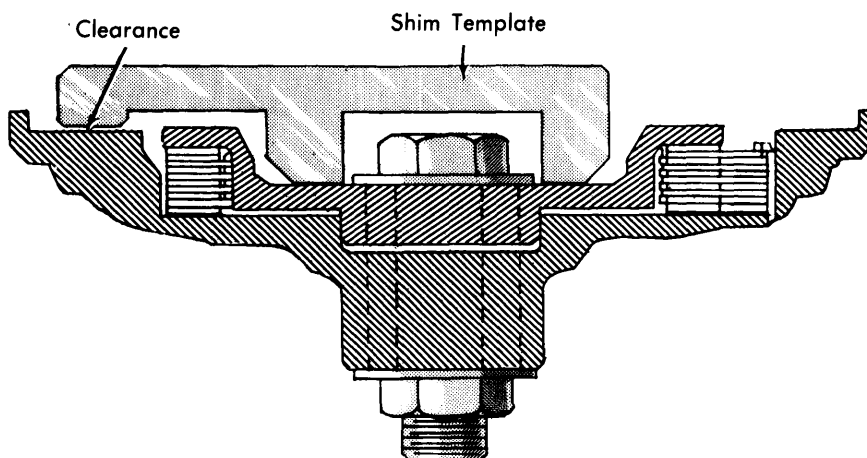

Fig. 4 Sectional View Showing Correct Usage of Shim Template Tool