

Clutches

JEEP

DESCRIPTION

Two types of clutches are used; a 10½" diameter direct spring pressure type; and an 11" semicentrifugal type. No internal adjustment for clutch disc wear is provided, but release lever height should be checked and adjusted. Clutch is actuated through mechanical type linkage.

REMOVAL & INSTALLATION

CLUTCH

Removal & Installation – Raise and support vehicle under frame and remove transmission. See appropriate article in *MANUAL TRANSMISSION SERVICING* Section. Disconnect rod and return spring at clutch fork. Remove throw-out bearing from clutch fork and remove clutch fork. Mark position of clutch cover on flywheel for reassembly. Install a suitable tool (J-5824) in clutch disc for support. Loosen clutch plate bolts one or two turns at a time until clutch plate spring tension is released. Remove clutch pilot tool and remove clutch plate and disc. To install, reverse removal procedure, making sure clutch hub and pilot bearing are aligned.

Installation – Check all components for wear or damage and replace as necessary. Using a suitable clutch alignment tool, align clutch disc and loosely install pressure plate, noting alignment marks made during removal. Reverse removal procedure to complete installation.

ADJUSTMENT

CLUTCH LINKAGE

Adjust outer bellcrank support to obtain approximately ⅛" bellcrank end play. Raise clutch pedal up to stop and adjust lower ball pivot assembly on pedal-to-bellcrank rod until inner bellcrank lever is parallel with front face of clutch housing. Adjust clutch fork release rod to obtain specified pedal free play.

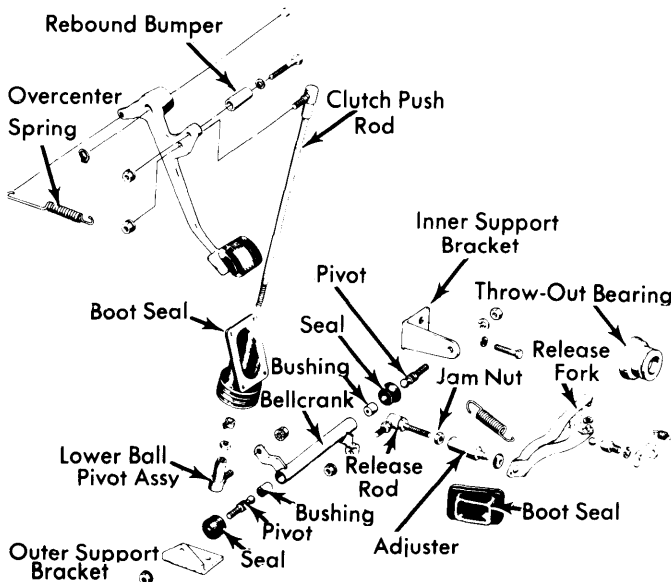

Fig. 1 Exploded View of Clutch Linkage Assembly Cherokee, Wagoneer and Truck Shown, CJ Models Similar

Clutch Pedal Free Play Specifications

Application	Specification
CJ Models	.88-1.0"
All Others	.38-.62"

CLUTCH RELEASE LEVER

Position a suitable gauge plate (J-1048) on flywheel. Position clutch cover over gauge plate with release fingers aligned with machined lands on plate. Gauge plate hub should be centered between release levers. Attach cover to flywheel, tightening cover screws in rotation, one or two turns at a time. Set each release lever by depressing two or three times. Measure height of each lever in relation to plate hub using a suitable height gauge tool (J-23330). Tool has four different dimensional settings. Turn adjusting lever nuts until all three levers are at specified height. Work levers up and down two or three times and recheck measurement.

Clutch Release Lever Height Specifications

Application	Height
CJ-5 & CJ-6	⅜-7/64"
All Others	⅜-7/64"
6 Cylinder Models	⅜-7/64"
8 Cylinder Models	3/16"

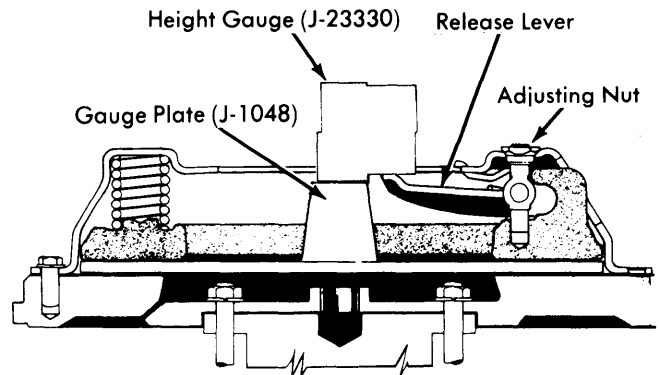

Fig. 2 Sectional View Showing Correct Method of Measuring Clutch Release Lever Height

TIGHTENING SPECIFICATIONS

Application	Ft. Lbs.
Clutch Cover-to-Flywheel Bolts	40
Clutch Housing-to-Engine Bolt	
6 Cylinder Models Top	35
6 Cylinder Models Bottom	45
8 Cylinder Models	30
Transmission-to-Clutch Housing Bolts	55