

# Propeller Shafts

## PROPELLER SHAFT ALIGNMENT

### DESCRIPTION

Propeller shafts are balanced, one piece, tubular shafts with universal joints at each end. Number in vehicle varies: one shaft, two shafts with center bearing, and three shafts in four-wheel drive applications. Location of slip joints varies with model and manufacturer (see illustration).

### INSPECTION

Vibration can come from many sources. Before overhauling driveline, other sources of possible vibration should be checked first.

**Tires & Wheels** – Check inflation and wheel balance. Check for damaged tread or foreign object in tread.

**Center Bearing** – Tighten drive shaft center bearing mounting bolts. If bearing insulator is deteriorated or oil soaked, it should be replaced.

**Engine & Transmission Mountings** – Tighten mounting bolts. If mountings are deteriorated, they should be replaced.

**Propeller Shaft** – Check propeller shaft for damage or dents that could affect balance. Check for undercoating adhering to shafts. If present, shafts should be thoroughly cleaned.

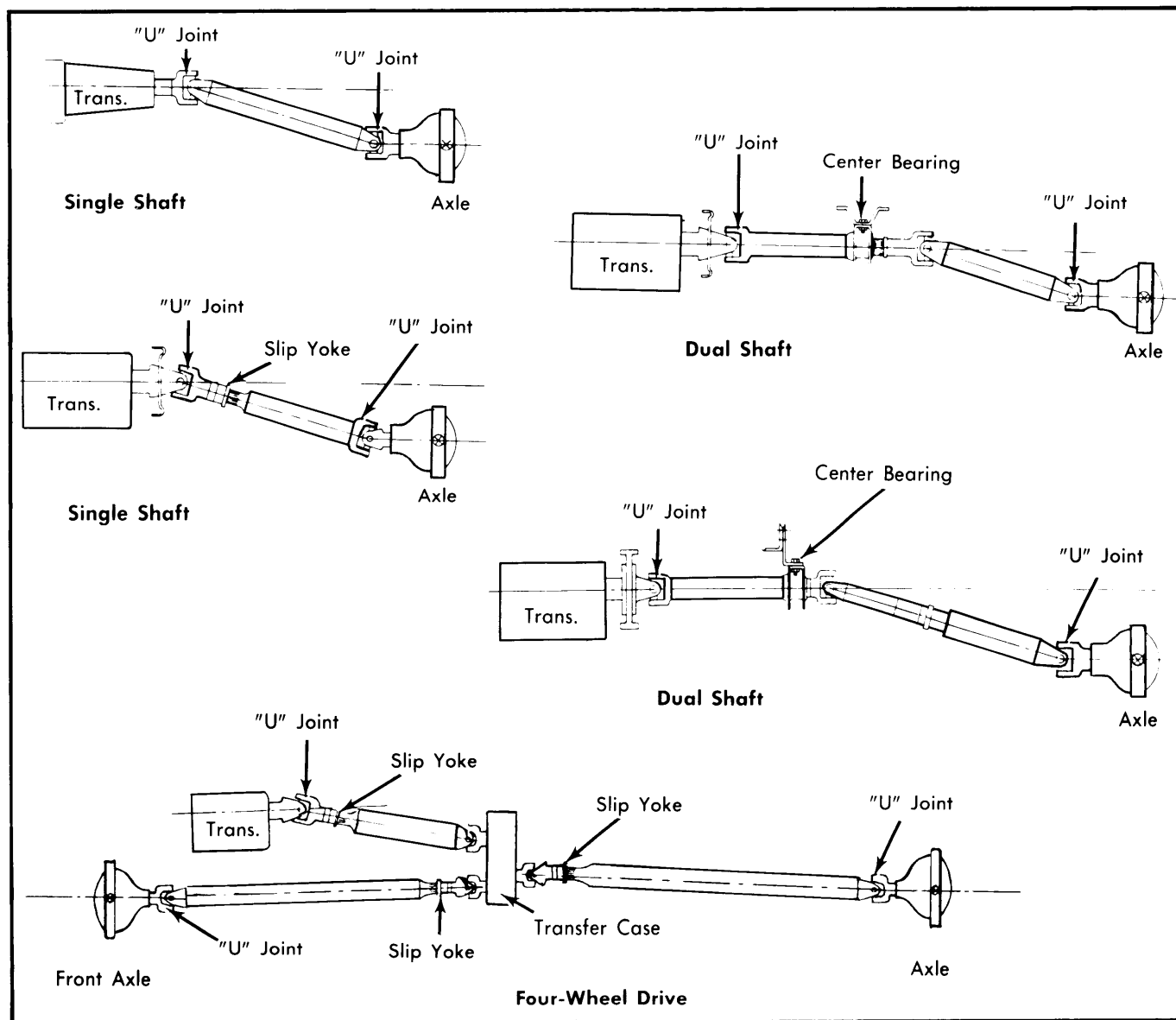

Fig. 1 Five Typical Propeller Shaft Combinations

## PROPELLER SHAFT ALIGNMENT (Cont.)

**Universal Joints** – Check for foreign material stuck in joints. Check for loose bolts and worn bearings.

### ADJUSTMENTS

**Propeller Shaft Phasing (Chevrolet & GMC)** – Three methods of phasing are used: For all models with 32 splines, parts will only fit together in one position because one spline is wider than the others. "C" and "G" models with 16 splines must be phased as shown in illustration. The rear shaft is rotated 90° (four splines) toward left side of vehicle after aligning vertically. "K" models with 16 splines are aligned with both yokes vertical.

**NOTE** – In certain cases, splines on slip joint are not uniform in width. This will match non-uniform pattern in female part of joint and allow for assembly in only one position. If flanges are not in phase after assembly, assembly is correct as long as parts were mated properly.

**Propeller Shaft Phasing (All Others)** – Check that flanges on either end of drive shaft are in same plane. Often there are arrows on slip joint and drive shaft to aid in alignment. If flanges are not in same plane, disassemble universal joint and align.

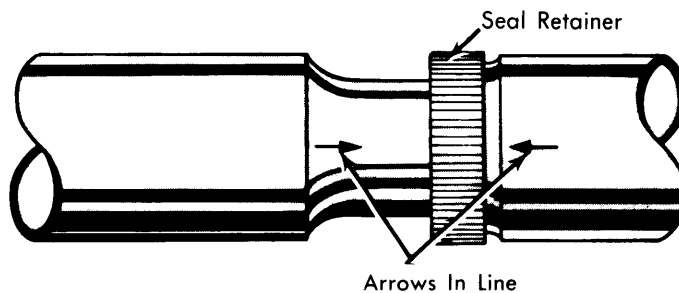

Fig. 2 View Showing Typical Slide Joint Alignment Arrows

**Propeller Shaft Balance** – Often propeller shaft imbalance can be cured by disconnecting shaft and rotating it 180° in relation to other components. Test by raising rear wheels off ground and turning shaft with engine. **CAUTION** – Avoid excessive engine speed during this type of test. If shaft still vibrates, attach a small weight to shaft at spline joint end. Weight should be about ½ oz. attached with hose clamp. Rotate shaft with engine and try weight in different locations around circumference of shaft to find position where vibration is least; then increase or decrease size of weight until vibration disappears. When proper size and location of weight are determined, tack weld weight into place.

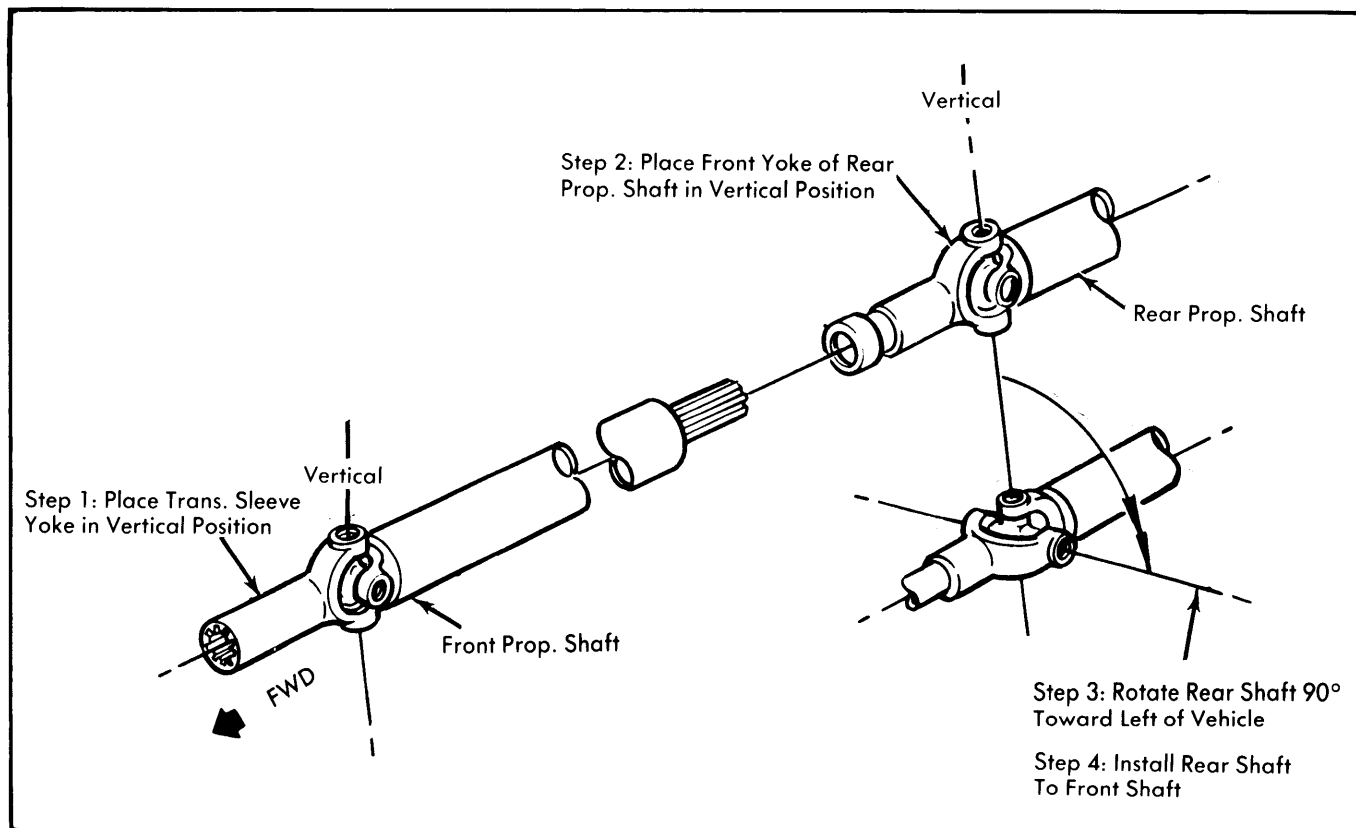

Fig. 3 View Showing Alignment of Universal Joints on Chevrolet & GMC Models "C" & "G" Only

# Propeller Shafts

## PROPELLER SHAFT ALIGNMENT (Cont.)

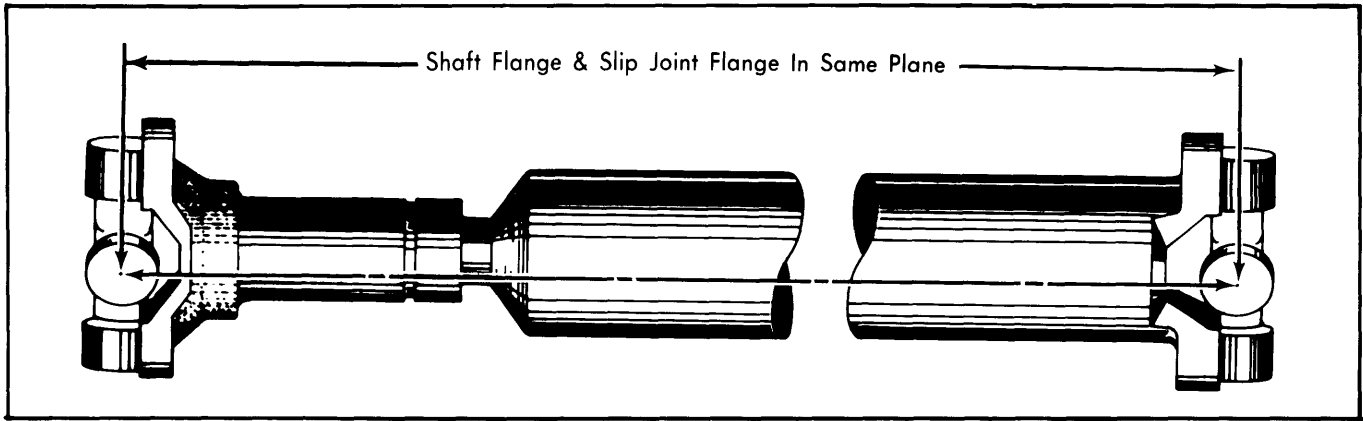

Fig. 4 View Showing Propeller Shaft Phase Alignment

**Flange Alignment & Runout** — 1) All flanges must be perpendicular in both vertical and horizontal planes to engine crankshaft. The only exception is "broken back" type driveline which has flanges that are not perpendicular in vertical plane (see illustration).

3) Parallel type joints maintain a constant velocity between output shaft and pinion shaft. Vibration is minimized and component life maximized when universal joints are parallel.

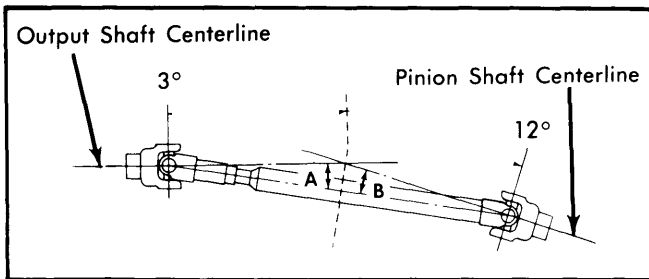

Fig. 5 View Showing Typical "Broken Back" Type Driveline Alignment

2) With nonparallel or "broken back" type installation, working angles of universal joints of a given drive shaft are equal. (See illustration, Angle A=Angle B.) This is calculated as follows: Angle of output shaft centerline is subtracted from angle of drive shaft, which should equal angle of drive shaft subtracted from pinion shaft angle.

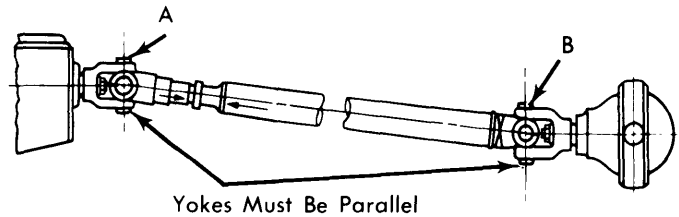

Fig. 7 View Showing One Piece Shaft Flange Alignment

4) Using dial indicator, measure runout of transmission flange, center bearing flange, and pinion flange. If runout exceeds .005", replace flange. If dial indicator cannot be used, push a rod with a slip fit through flange bearing bore and see if it aligns with opposite bore; if it does not, replace flange.

5) Rotate transmission flange until it is vertical, measuring from side. Check center bearing and pinion flanges; they cannot be more than 1° off vertical. **NOTE** — See Propeller Shaft Phasing in this article.

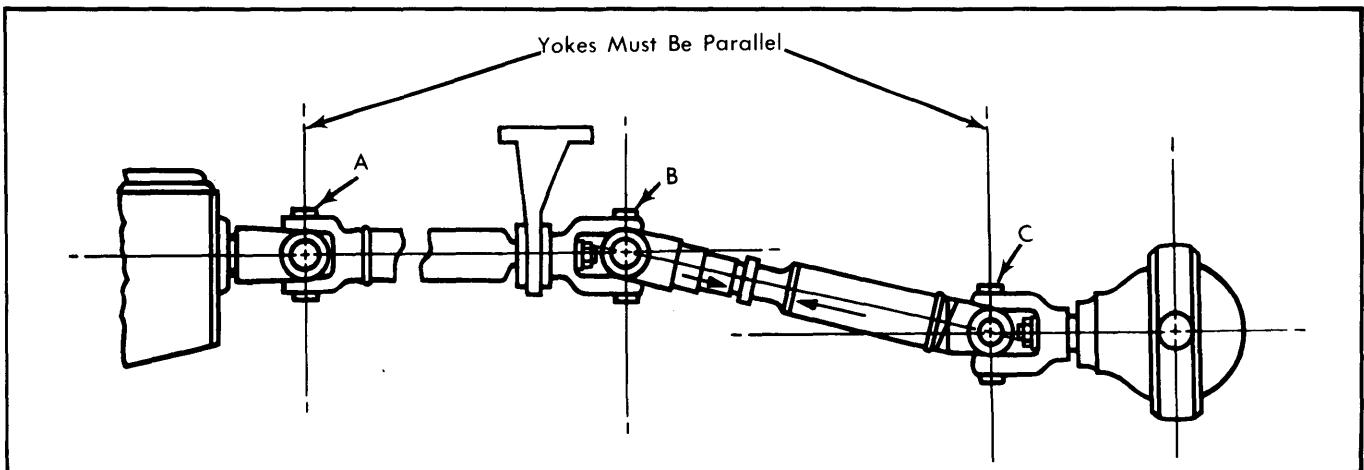

Fig. 6 View Showing Two Piece Shaft Flange Alignment

## PROPELLER SHAFT ALIGNMENT (Cont.)

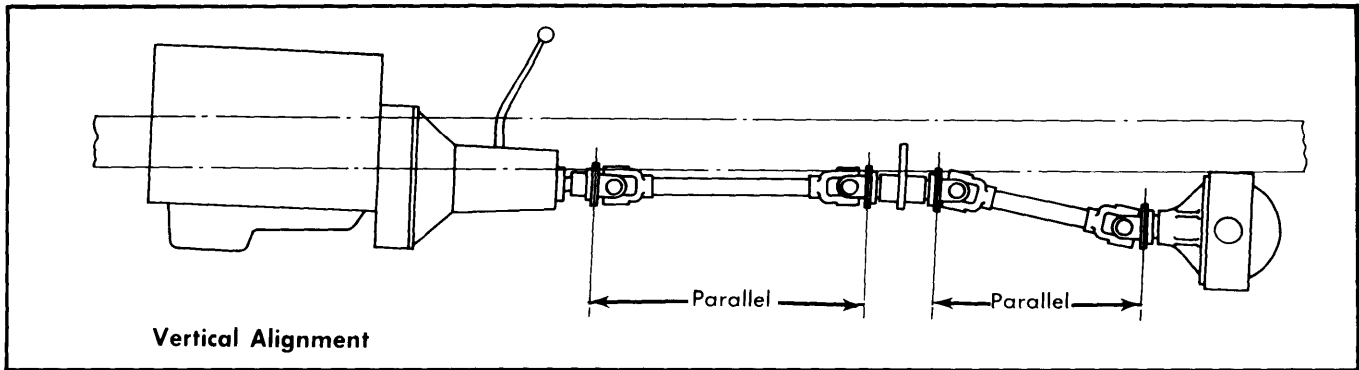

Fig. 8 View Showing Propeller Shaft Vertical Alignment

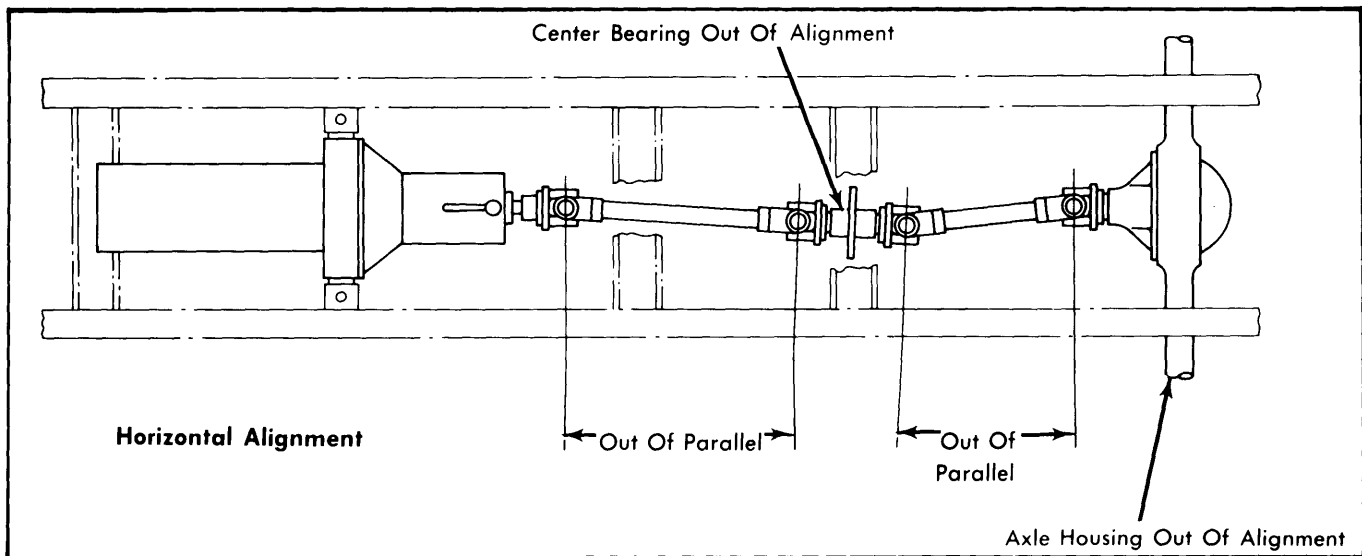

Fig. 9 View Showing Propeller Shaft Horizontal Alignment

6) Rotate transmission flange until it is vertical, measuring from side. Then measure angle from end and record. Check all other flanges for same angle. They must be within  $\frac{1}{2}^\circ$  of each other. Adjust as required.

7) If difficulty is encountered when making above adjustments, horizontal alignment should be checked. As shown in illustration, even though vertical alignment is correct, horizontal alignment can be badly out of adjustment especially after major component replacement or serious accident.

8) To make horizontal alignment checks, set up straightedges as shown in illustration. With transmission flange horizontal, clamp a straightedge to it so that straightedge is horizontal. Do the same with pinion flange. Using a straightedge that is 12" longer than rear wheel track, clamp it to frame side rails using large framing squares to align.

9) Measure distance "X". If two dimensions are not within  $\frac{1}{16}$ " of each other, transmission flange is misaligned horizontally. Measure distance "W". If two dimensions are not within  $\frac{1}{16}$ " of each other, pinion flange is misaligned horizontally. Measure

distance "Y", from edge of straightedge to center of axle shaft. If two dimensions are not within  $\frac{1}{8}$ " of each other, axle housing is misaligned.

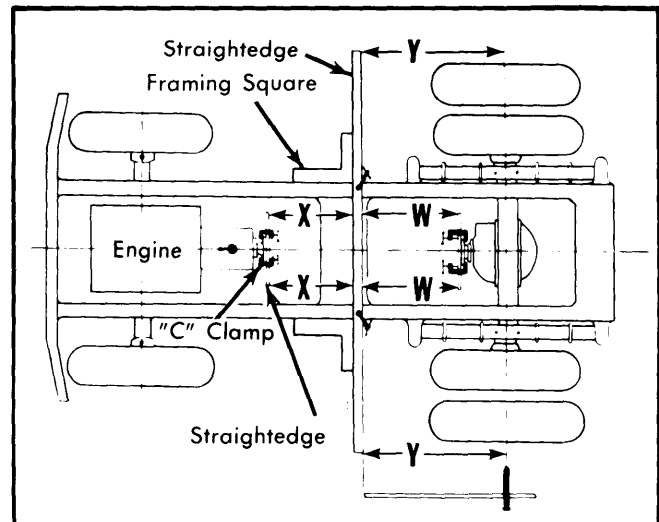

Fig. 10 Correct Procedure to Check Horizontal Alignment