

350" V8 DIESEL ENGINES

IDENTIFICATION CODING

ENGINE IDENTIFICATION

Engines may be identified by codes found stamped on pad at right front side of cylinder block. Code letters are suffix of Engine Identification Number. Codes are as follows:

Application	Chevrolet & GMC	
	Man. Trans.	Auto. Trans.
350"		
Federal		QV
Calif.		QV
High Altitude		QV

ENGINE REMOVAL

See *Engine Removal* at end of *ENGINE* Section.

CYLINDER HEAD & MANIFOLDS

INTAKE MANIFOLDS

Removal — 1) Drain cooling system, remove air cleaner and disconnect all hoses and wiring as necessary. Remove breather pipes and air crossover. Cap intake manifold with cover screens (J-26996-2).

2) Disconnect throttle rod, spring and remove retaining clip from bellcrank. Remove throttle cable from bracket and position away from engine. Remove alternator and A/C bracket as necessary.

3) Disconnect fuel lines to fuel pump, filter, nozzles and injection pump. Remove injection pump, fuel filter and brackets. Cap all open fuel lines and fittings.

4) Remove vacuum pump, drain tube, intake manifold and injection pump adapter.

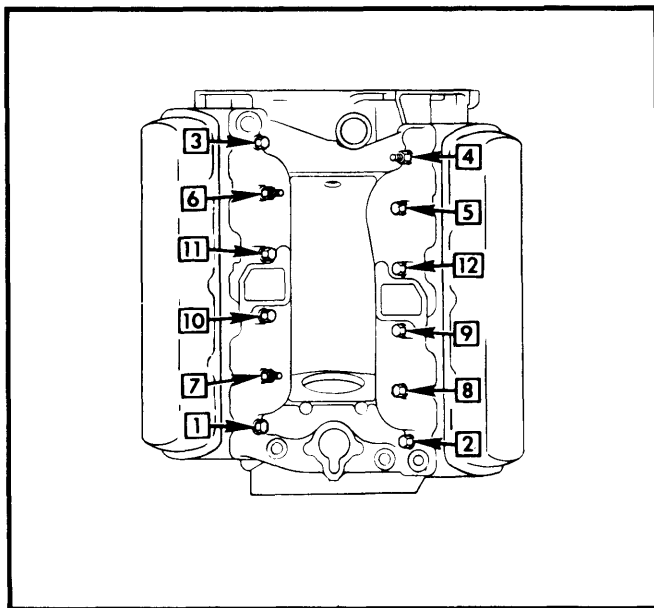

Fig. 1 Intake Manifold Tightening Sequence

Installation — 1) Clean machined surfaces of manifold and head. Use suitable sealer to coat both sides of gasket and position on head. Install end seals and intake manifold making sure that ends are positioned under cylinder heads.

2) Dip manifold bolts in oil and tighten in two steps. See Fig. 2. Install drain tube and apply chassis lube to seal area on adapter, taper edge and seal area of manifold. Use seal installing tool (J-28425) to properly position seal on adapter, then tighten bolts.

3) Align offset tang on pump drive shaft with offset in pump driven gear and install injection pump. Connect lines to pump and nozzles. Align marks on injection pump with mark on adapter.

4) Install vacuum pump, oil pump drive assembly, injection pump and fuel filter and bracket. Install air crossover and breather pipes. Install alternator and A/C bracket (if removed). Connect all wiring and hoses. Fill cooling system.

CAUTION — Do not operate engine without vacuum pump assembly, as this is the drive for the oil pump.

EXHAUST MANIFOLDS

Removal & Installation — The right-hand manifold must be removed from the bottom of engine. The left-hand manifold comes out from the top. The oil cooler lines must be removed from base of filter in order to get crossover pipe out. Also the right front wheel may have to be removed. To install, reverse removal procedure.

CYLINDER HEAD

Removal — 1) Drain cooling system and remove or disconnect all necessary lines, hoses, brackets and linkage. Remove intake and exhaust manifolds. Remove engine block drain plug on same side as cylinder head being removed.

2) If necessary to remove pre-chamber, remove glow plug and injection nozzle, then tap out with a small drift punch. Remove ground strap, rocker arm bolts, pivots, rocker arms and push rods. Keep all removed parts separate for installation in original locations.

Installation — 1) Install head gasket WITHOUT sealer. Install pre-chamber (if removed), glow plug and injection nozzle, then head.

2) Clean and dip cylinder head bolts in engine oil and tighten in two steps. See Fig. 2.

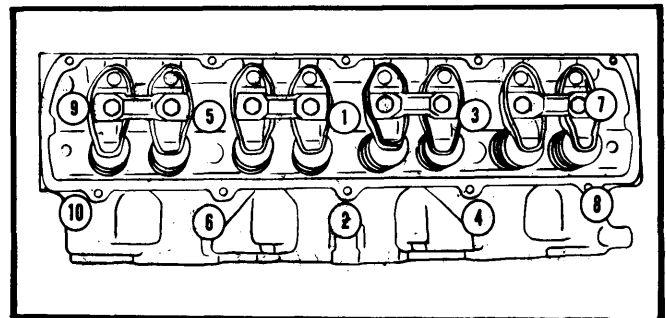

Fig. 2 Cylinder Head Tightening Sequence

350" V8 DIESEL ENGINES (Cont.)

VALVES

VALVE ARRANGEMENT

I-E-I-E-E-I-E-I

VALVE GUIDE SERVICING

Intake and exhaust valve guides are integral with cylinder head. Valves are available in Standard, .003", .005", .010" and .013" oversize.

NOTE — Use .003" oversize reamer for Standard and .003" oversize valves. Use .005" oversize reamer for .005" oversize and .013" oversize reamer for .010" and .013" oversize valves.

VALVE STEM OIL SEALS

Install oil seal down as far as possible on valve stem. Seals will correctly position when engine is started. The valve stem oil seals are color coded as follows:

Intake — Gray: Standard to .005" oversize.
 Orange: .010" to .013" oversize.
 Exhaust — Ivory: Standard to .005" oversize.
 Blue: .010" to .013" oversize.

VALVE SPRINGS

Removal — With cylinder head removed, remove valve keys using valve spring compressing tool (J-5892-1) to compress spring. Remove retainers, spring and seal. Keep components separate for reinstallation in original location.

Inspection — Check for squareness of valve spring as shown in Fig. 3. Spring must be within $\frac{1}{16}$ " square in free position.

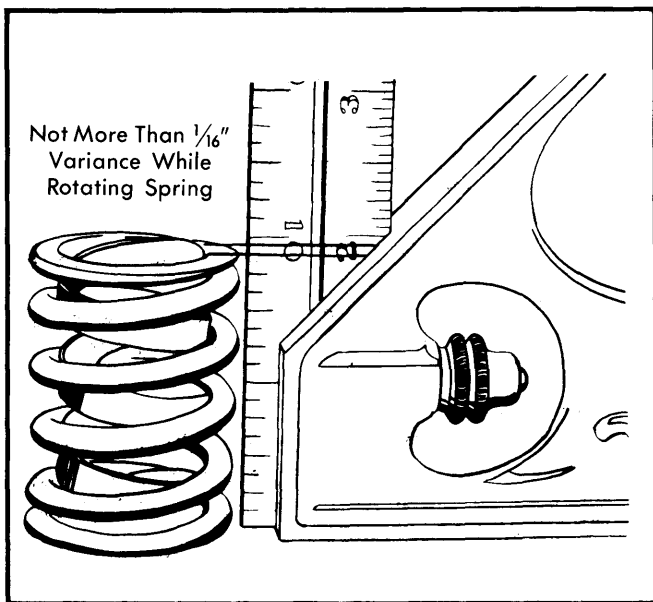

Fig. 3 Checking Valve Spring

Installation — 1) Use suitable tool to install retainer, spring and valve stem keys. Check spring and keys to be sure they are properly seated.

2) Measure valve stem height whenever new valve is installed or after grinding valve. Use valve stem height gauge (J-25289) shown in Fig. 4. There should be at least .015" clearance between gauge and valve stem. If clearance is less than .015", grind tip as required.

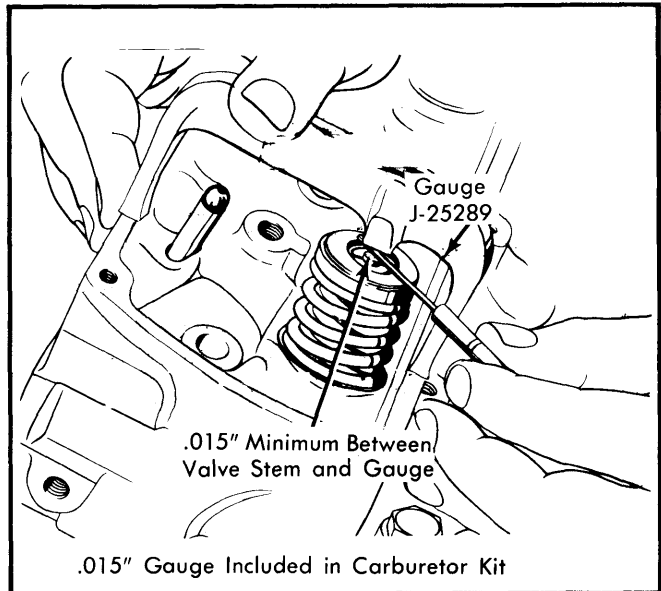

Fig. 4 Measuring Valve Stem Height

3) Measure clearance between gauge and valve rotator. Clearance must be .030" minimum. If any valve is less than .005" above rotator, valve is too short and must be replaced. See Fig. 5.

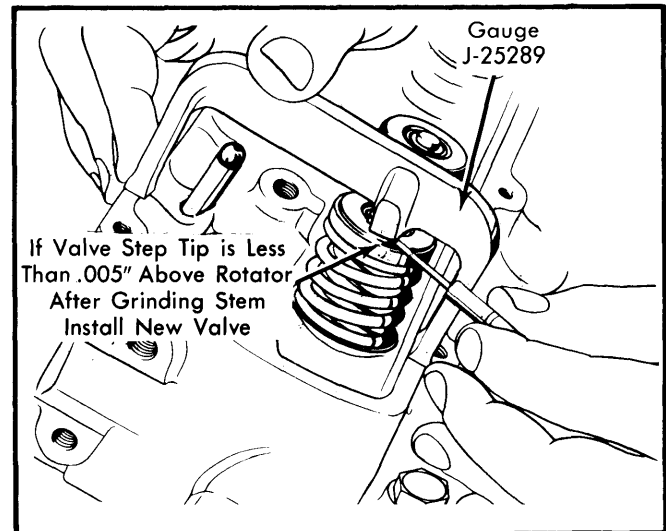

Fig. 5 Measuring Rotator Height

ROCKER ARM ASSEMBLY

Removal & Installation — Remove valve cover, rocker arm flanged bolts, pivot and rocker arms. Remove each set (one set per cylinder) as a unit. To install, position one set of rocker arms in proper location. Lubricate wear points with suitable

350" DIESEL ENGINES (Cont.)

lubricant and install pivots. Install flanged bolts and tighten alternately to proper torque.

NOTE — Refer to "Valve Lifter Bleed Down" as lifters must be bled down to prevent piston from hitting valves.

HYDRAULIC VALVE LIFTER ASSEMBLY

NOTE — Hydraulic valve lifters installed in this engine are not the same as used in gasoline engines.

Removal — 1) With head removed, remove valve lifter, being sure to keep separate for installation in same location.

2) Whenever lifters are removed, check lifter foot for abnormal wear as follows: Place a straightedge across foot of lifter while holding lifter at eye level. Check for light between foot and straightedge. If light indicates a concave surface, lifter must be replaced and camshaft inspected.

Disassembly — With small screwdriver, remove retainer ring. Remove push rod seal and oil metering valve. Remove plunger and spring. Remove check valve retainer from plunger, then remove valve and spring. See Fig. 6.

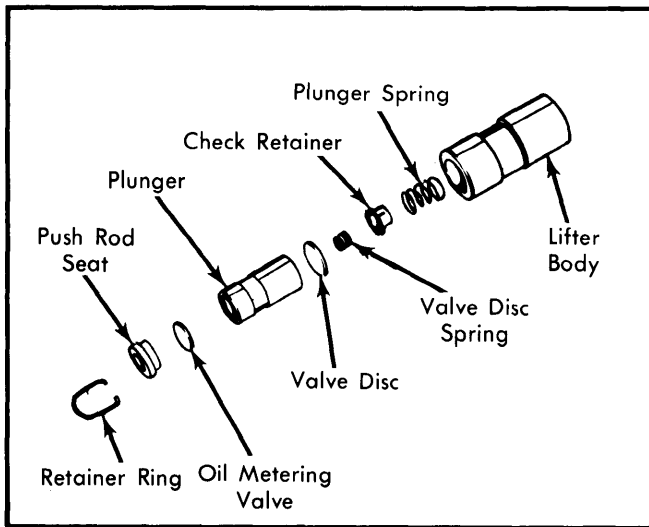

Fig. 6 Valve Lifter

Assembly — Assemble lifter while submerged in kerosene or diesel fuel, and leak-down test before putting into service. Follow manufacturers instructions for leakdown test.

VALVE LIFTER BLEED DOWN

1) If intake manifold has been removed and if any rocker arms have been loosened or removed, disassemble and drain engine oil completely, then reassemble lifters while submerged in clean fuel oil.

2) If intake manifold has not been removed, but rocker arms have been loosened or removed, valve lifters can be bled down by the following procedure:

- For cylinders 3, 5, 7, 2, 4 & 8, turn crankshaft so slot on harmonic balancer is at 0° on timing indicator.
- For cylinders 1, 3, 7, 2, 4 & 6, turn crankshaft so slot is at 4 o'clock position.
- Tighten rocker arm pivot bolts to 25 ft. lbs.

NOTE — It will take up to 45 minutes for the valve lifters to bleed down completely.

PISTONS, PINS & RINGS

OIL PAN

See Oil Pan Removal at end of ENGINE Section.

PISTONS & ROD ASSEMBLY

Removal — 1) Remove intake manifold, heads, oil pan and oil pump. Mark rod and caps for reinstallation in same cylinder. Use ridge reamer to remove any deposits or ridge on upper end of cylinder bore.

NOTE — Pistons must be at bottom of stroke and covered with cloth to collect cuttings.

2) Remove rod cap and use guide hose over threads of rod bolts to prevent damage to journals and threads. Remove rod and pistons out top of block.

Installation — 1) Lightly coat pistons, rings and cylinder walls with engine oil. Position rings as shown in Fig. 7. Make sure the marks on piston rings are toward top of piston. Using piston ring compressor, install piston with valve depression in top of piston turned toward inner side of engine.

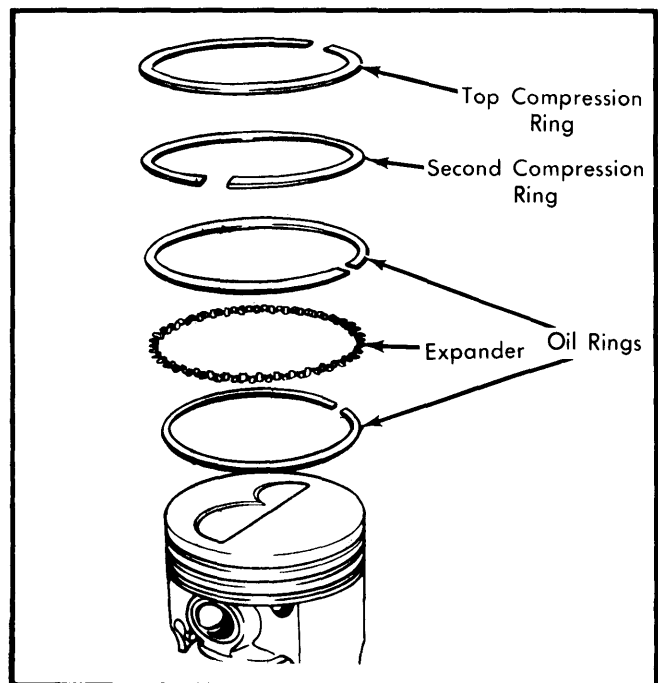

Fig. 7 Piston Rings

2) On cylinders 1, 2, 3 & 4, the larger valve depression goes toward the front of engine. On cylinders 5, 6, 7 & 8, the larger depression goes toward rear of engine. See Fig. 8.

350" V8 DIESEL ENGINES (Cont.)

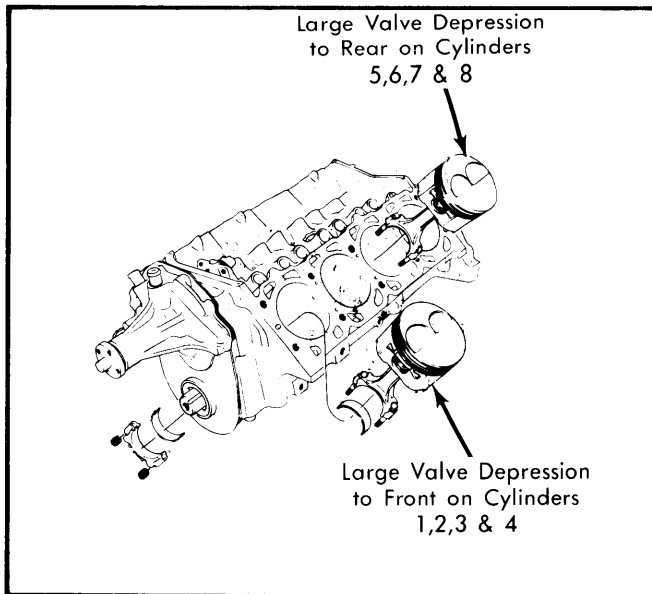

Fig. 8 Piston Location

FITTING PISTONS

With pin removed, measure for taper at pin centerline and bottom of skirt. Measure for size $\frac{3}{4}$ " below centerline on skirt. Allowable taper is 0-.002". Measure cylinder bore with dial indicator. Maximum allowable taper and out-of-round is .001"

PISTON PINS

Piston pin is free floating and can be inserted into piston or rod with hand pressure. Be sure that piston and rod pin holes are clean and free of oil when checking pin fit. Rotate piston pin retaining snap rings until fully seated in grooves.

CRANKSHAFT & ROD BEARINGS

CONNECTING ROD & MAIN BEARINGS

Connecting Rod Bearings – 1) These bearings are designed to have slight projection above the rod and cap faces to ensure positive contact. They may be replaced without removing rod and piston assembly from engine.

2) Measure connecting rod journals with a micrometer to check out-of-round. Maximum out-of-round must not exceed .0035". Use Plastigage method to check bearing clearance. Coat bearings with engine oil before installation.

NOTE – All rods must be connected to journals before rotating crankshaft to prevent damage to engine.

3) Measure connecting rod side clearance by spreading rods with screwdriver and inserting feeler gauge. Clearance should be .006-.020".

Main Bearings – 1) Check bearing clearance. Use floor jack or other support to hold crankshaft against upper bearing half.

2) Use Plastigage across full width of bearing. Install cap with bearing and tighten to 120 ft. lbs. Determine bearing

clearance by removing cap and check flattened Plastigage with graduations on container. If clearance is greater than .0035", replace BOTH bearing halves as a set.

NOTE – Do not use shims.

3) To replace main bearing halves, remove caps and lower shell. Insert a flattened cotter pin or rollout pin in oil passage hole of crankshaft. Rotate crankshaft in opposite direction of cranking rotation

4) Check journals for roughness and wear. Out-of-round may be measured by inside micrometer or crankshaft caliper. Upper half must be removed when measuring journals. Maximum allowable out-of-round is .0015". Apply suitable lubricant to thrust flanges of No. 3 bearing. Reverse procedures to install new bearing halves.

REAR MAIN BEARING OIL SEAL

Rear main bearing oil seal can be installed without removing crankshaft. The procedure for seal leak correction is as follows:

1) Drain oil, remove oil pan and rear main bearing cap. Use packing tool (J-25286) against end of seal and drive oil seal into groove until it is packed tight. This may vary from $\frac{1}{4}$ " to $\frac{3}{4}$ ", depending on amount of pack required. Repeat on other end of seal.

2) Measure amount seal was driven up on one side; add $\frac{1}{16}$ ", then cut this length from old seal removed from bearing cap. Repeat on other side, again adding $\frac{1}{16}$ ", then cut this length off. Place a drop of suitable sealer on each end of seal and cap. Using two small screwdrivers, work these two pieces (one on each side) into block seal groove.

3) Use packing tool to force short pieces into block. Cut seal flush with block. Place a piece of shim stock between crankshaft and seal to protect bearing surfaces before trimming.

4) Form a new rope seal in cap, packing it by hand. Use rear main seal installing tool and hammer seal into groove.

NOTE – Seal is fully seated if undercut area of tool slides over seal. If tool butts against seal, drive seal further into groove.

5) Rotate tool before cutting off excessive packing. Reinstall cap and tighten to specifications.

CAMSHAFT

ENGINE FRONT COVER

Removal – Drain cooling system and remove radiator and by-pass hoses. Remove belts, fan and fan pulley, crankshaft pulley, harmonic balancer and accessory brackets. Remove cover attaching bolts, cover, timing indicator and water pump. Remove both dowel pins.

Installation – 1) Grind a chamfer on one end of dowel pin. Cut excessive material from end of oil pan gasket on each side of block. Clean all mating surfaces with solvent. Trim $\frac{1}{8}$ " from each end of new pan seal. Install new front cover gasket on

350" V8 DIESEL ENGINES (Cont.)

block and new seal on front cover. Apply suitable sealer to gasket around coolant holes and place on block.

2) Apply suitable sealer at junction of block, pan and front cover. See Fig. 9. Install front cover, pressing downward to compress seal. Rotate cover left and right to guide pan seal into cavity using a small screwdriver. See Fig. 10. Install dowel pins (chamfered end first), timing indicator and water pump. Lube seal surface and install harmonic balancer. Install brackets, all pulleys, fan and belts. Install radiator and bypass hoses. Fill cooling system.

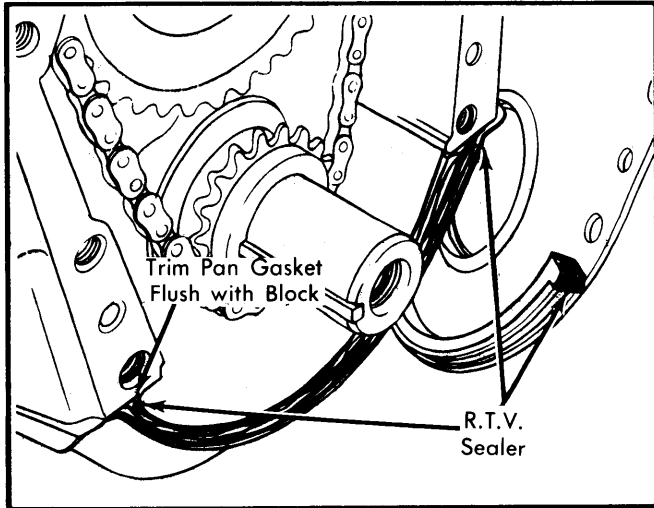

Fig. 9 Pan and Cover Seal Installation

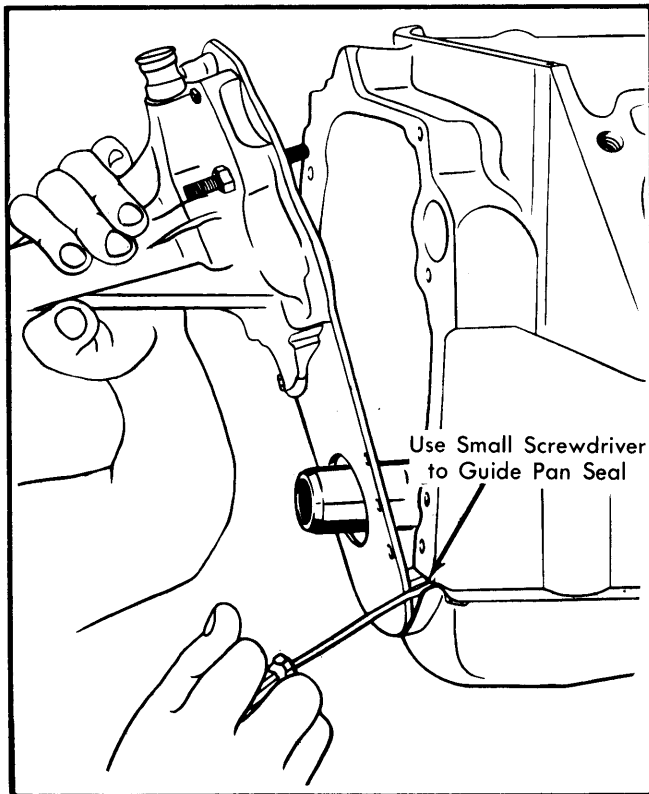

Fig. 10 Front Cover Installation

FRONT COVER OIL SEAL

Removal – Remove belts, harmonic balancer, crankshaft pulley and hub. Remove front cover oil seal.

Installation – Apply sealer to outside of seal. Use seal installer (J-25264 and J-23952) to position and install seal. Replace all other components.

TIMING CHAIN

Removal – Remove front cover, oil slinger, cam gear, crankshaft gear and key. Remove timing gear. Remove fuel pump eccentric only if replacement is necessary.

Installation – Install crankshaft key, oil slinger, camshaft gear, crankshaft gear and timing gear together.

NOTE – When the two marks are aligned, No. 6 cylinder is at TDC. To obtain TDC for No. 1 cylinder, slowly rotate crankshaft one rotation. This will bring cam mark to the top. No. 1 will then be in firing position. See Fig. 11.

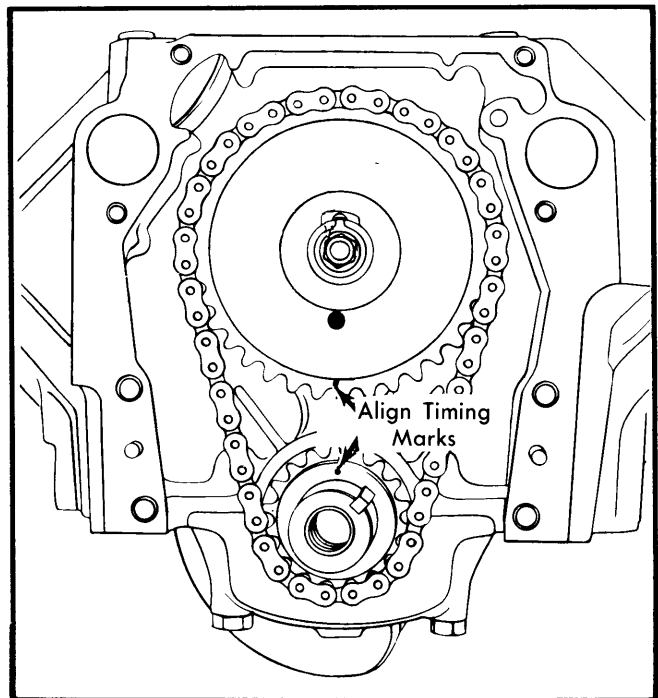

Fig. 11 Aligning Timing Marks

CAMSHAFT

Removal – 1) Drain cooling system, disconnect radiator hoses, cooler lines and remove radiator. Remove air crossover, all hoses, lines, wiring and linkage to intake manifold and remove manifold.

2) Remove pulleys, harmonic balancer, front cover, valve covers, rocker arms, push rods and lifters. If equipped with air conditioning, discharge system and remove condenser. Remove timing chain and gears.

3) Position camshaft dowel at 3 o'clock position. Hold camshaft to rear and remove pump drive gear by sliding off camshaft while rocking pump driven gear. Remove injection

350" V8 DIESEL ENGINES (Cont.)

pump adapter, then remove snap ring and selective washer. Remove driven gear and spring. Remove camshaft carefully sliding out front of engine.

NOTE — Do not force shaft as damage can occur to bearings.

Installation — To install camshaft, reverse removal procedure. Apply suitable lubricant to camshaft and bearings prior to installation.

CAMSHAFT BEARINGS

Removal — 1) Oil pan must be removed to replace camshaft bearing.

NOTE — Camshaft bearings are replaced as a complete set only. All bearings must be removed first before installing new bearings.

2) Remove camshaft. Use bearing remover set (J-6098-01) and handle (J-8092) to drive out camshaft bearings. Remove bearings in sequence, starting with No. 1.

3) To remove injection pump driven gear bushings, drive both bushings out at the same time from rear to front of block, using pump drive shaft tool (J-28439-2 & J-8092).

Installation — 1) To install, reverse procedure and place each bearing in front of bore with tapered edge toward block.

NOTE — Install bearings beginning with No. 5.

2) Align oil hole in bearings with center of oil slot in each bore. Mark bottom of bearing to act as a guide. Use a piece of $\frac{3}{32}$ " brass rod with a 90° bend at one end to check oil hole opening. Wire must enter hole. Fig. 12.

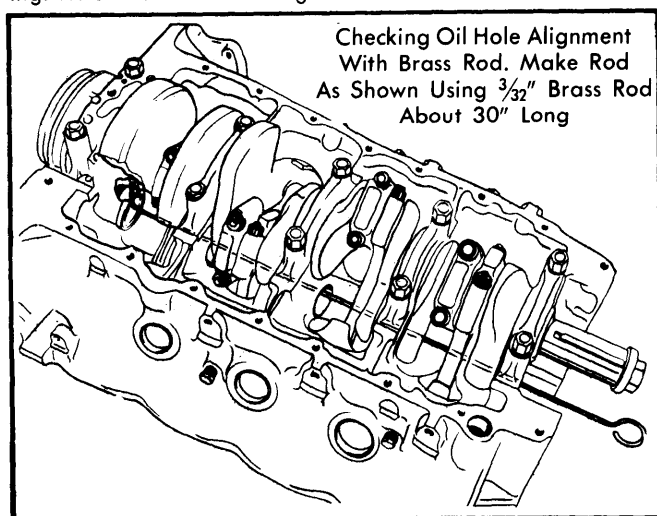

Fig. 12 Checking Oil Holes

ENGINE TIMING

For the engine to be properly timed, align marks on top of injection pump adapter and flange of injection pump.

ENGINE OILING

Crankcase Capacity — 6 qt. Add 1 qt. with filter change.

Normal Oil Pressure — 35 psi minimum at 1500-3000 RPM.

Pressure Regulator Valve — Located in pump cover. Not adjustable.

ENGINE OILING SYSTEM

Oil pump is gear type driven by camshaft gear through hexagonal drive shaft. Oil is delivered to right gallery where it is distributed to the five main bearings. The right bank valve lifters receive oil from this gallery through eight feed holes that intersect gallery. Camshaft bearings are lubricated from vertical passages intersecting main bearing oil passages and the left bank lifters receive oil through connecting passages from right gallery. The injection pump driven gear gets oil from passages in front camshaft bearing.

Rear driven gear bearing receives oil from passage in shaft of driven gear and vacuum pump is oiled by orifice in rear oil gallery plug. An orifice in front of right gallery lubricates the timing chain and fuel pump eccentric. Rocker arms and valve tips are lubricated through lifters and hollow push rods. Vacuum pump driven gear is oiled through left rear gallery and connecting rod bearings receive oil from drilled passages in crankshaft. Grooves around each main bearing furnish oil to drilled crankshaft passages.

OIL PUMP

Disassembly — Remove oil pump drive shaft extension and pump cover

NOTE — Do not remove washer from extension.

Remove cotter pin, spring and pressure regulator valve. Remove drive gear and idler gear from pump body. See Fig. 13.

NOTE — Spring is under pressure, be careful when removing cotter pin.

Assembly — Install idler and drive gear in pump body. Check gear end clearance by placing straightedge over gears and measuring clearance between straightedge and gasket surface. Clearance must be .0005-.0075". If end clearance is near top reading, check for scores in cover that would bring total clearance over specified amount. Reinstall pressure regulator valve, spring and cotter pin.

NOTE — When installing extension, the end nearest washer must be inserted into drive shaft.

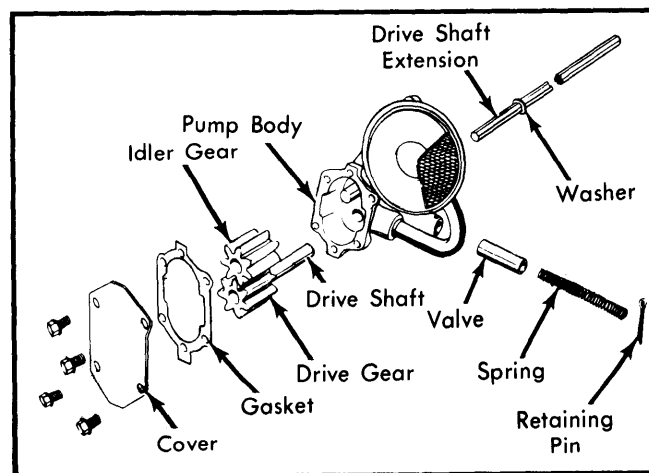

Fig. 13 Oil Pump

General Motors V8 Engines

350" V8 DIESEL ENGINES (Cont.)

ENGINE SPECIFICATIONS (Cont.)

GENERAL SPECIFICATIONS							
Engine	Cycle	Displ. Cu. Ins.	Compr. Ratio	Bore	Stroke	Firing Order	Inj. Timing
1979	4	350"	22.5-1	4.057"	3.385"	1-8-4-3-6-5-7-2

VALVES							
Engine & Valve	Head Diam.	Face Angle	Seat Angle	Seat Width	Stem Diameter	Stem Clearance	Valve Lift
350" Int.	1.875"	44°	45°	.075-.098"	.3425-.3432"	.0010-.0027"
Exh.	1.625"	30°	31°	.037-.075"	.3420-.3427"	.0015-.0032"

PISTONS, PINS, RINGS						
Engine	PISTONS		PINS		RINGS	
	Clearance	Piston Fit	Rod Fit	Rings	End Gap	Side Clearance
350"	.005-.006"	.0003-.0005"	.0003-.0013"	1	.015-.025"	.005-.007"
				2	.015-.025"	.0018-.0038"
				3	.015-.055"	.001-.005"

CRANKSHAFT MAIN & CONNECTING ROD BEARINGS							
Engine	MAIN BEARINGS				CONNECTING ROD BEARINGS		
	Journal Diam.	Clearance ^①	Thrust Bearing	Crankshaft End Play	Journal Diam.	Clearance	Side Play
350"	2.9993-3.0003"	.0005-.0021"	No. 3	.0035-.0135"	2.1238-2.1248"	.0005-.0026"	.006-.020"

① — Journals 1,2,3 & 4. No. 5 journal .0015-.0031"

VALVE SPRINGS			
Engine	Free Length	PRESSURE (LBS.)	
		Valve Closed	Valve Open
350"	2.09"	76-84 @1.70"	137-151 @1.336"

CAMSHAFT			
Engine	Journal Diam.	Clearance	Lobe Lift
350" No.1	2.0357-2.0365"	.0020-.0058"
No.2	2.0157-2.0165"	.0020-.0058"
No.3	1.9957-1.9965"	.0020-.0058"
No.4	1.9757-1.9765"	.0020-.0058"
No.5	1.9557-1.9565"	.0020-.0058"

TIGHTENING SPECIFICATIONS	
Application	Ft. Lbs.
Camshaft Sprocket Bolt	65
Connecting Rod Nut	42
Crankshaft Bearing Cap Bolt	120
Cylinder Head	130 ^①
Engine Front Cover	35
Exhaust Manifold-to-Cylinder Head Bolts	25
Flywheel-to-Crankshaft	60
Injection Pump Adapter	25
Injection Pump Nuts	19
Intake Manifold	40 ^①
Oil Pan Bolts	10
Oil Pump Cover Bolts	8
Oil Pump	35
Rocker Arm Pivot Bolts	25
Vibration Damper	200-310
Water Pump-to-Front Cover Bolts	13

① — Dip entire bolt in engine oil to get correct torque reading.