

# Jeep V8 Engines

## 6.0 LITER V8

### IDENTIFICATION CODING

#### ENGINE IDENTIFICATION

Engine code number is located on a plate, attached to front of right rocker cover. Letter portion of code identifies engine displacement, carburetor type and compression ratio.

#### ENGINE IDENTIFICATION CODE

Engine	Code
6.0L (360") 2-Bbl. ....	N

#### SPECIAL ENGINE MARKS

Some engines are produced at factory with oversize or undersize components. These engines are identified by a letter code, stamped adjacent to engine code number on right valve cover. Letters are decoded as follows:

- "B" indicates all cylinder bores .010" (.25 mm) oversize.
- "M" indicates all main bearings .010" (.25 mm) undersize.
- "F" indicates all connecting rod bearings .010" (.25 mm) undersize.
- "PM" indicates all connecting rod and main bearings .010" (.25 mm) undersize.
- "C" indicates all camshaft bearing bores .010" (.25 mm) oversize.

#### ENGINE REMOVAL

See *Engine Removal* at end of ENGINE Section.

### CYLINDER HEAD & MANIFOLD

#### INTAKE MANIFOLD

##### Removal

1) Drain coolant from radiator and cylinder block. Remove air cleaner. Disconnect spark plug wires from spark plugs and position wires and plastic separators away from intake manifold area.

2) Disconnect upper radiator hose, by-pass and heater hoses from intake manifold. Disconnect primary and secondary ignition wires from coil. Remove coil and bracket.

3) Label and disconnect all electrical connectors, ventilation hoses and vacuum hoses from intake manifold, carburetor and distributor. Disconnect fuel line from carburetor. Disconnect throttle linkages from carburetor and intake manifold, and position aside.

4) Disconnect air pump hoses from air pump and injection manifolds. Position hoses and diverter valve aside. Remove carburetor. Remove intake manifold. Discard gasket and seals.

##### Installation

1) Clean all gasket mating surfaces. Coat both sides of new gasket with non-hardening sealer. Position gaskets onto cylinder heads. Install new end seals. Apply non-hardening sealer to seal ends.

2) Install and tighten intake manifold. Install remaining components in reverse order of removal.

#### CYLINDER HEAD

##### Removal

1) Disconnect negative battery cable. Drain cooling system and cylinder block. Remove air cleaner

and rocker arm covers. Alternately loosen rocker arm bolts 1 turn at a time to avoid damage to bridges, and remove rocker arm assemblies and push rods. Keep rocker arm assemblies and push rods in order for reinstallation in original locations.

2) Remove spark plugs. Remove intake and exhaust manifolds. Loosen all drive belts. If A/C equipped, remove compressor mounting bracket. Disconnect alternator support brace from cylinder head.

3) Remove air pump and power steering pumps and their respective mounting brackets, and position aside. Remove cylinder heads and discard gaskets.

##### Installation

1) Clean threads of head bolts and threads in cylinder block. Clean all gasket mating surfaces. Apply an even coat of sealer to both sides of head gaskets. Position gasket on block with stamped word "TOP" facing upward.

2) Install and tighten cylinder head. See Fig. 1. To complete installation, reverse removal procedure. It is not necessary to retighten head bolts after engine has been operated.

Fig. 1: Cylinder Head Tightening Sequence

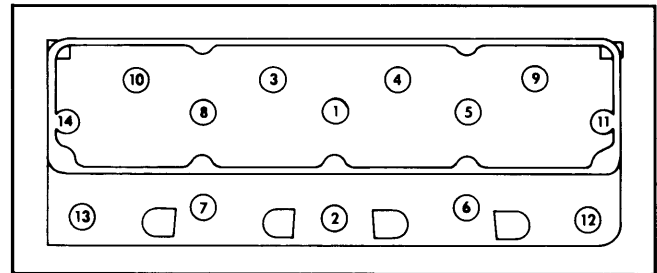

Tighten head bolts to 110 ft. lbs. (149 N.m).

### VALVES

#### VALVE ARRANGEMENT

E-I-I-E-E-I-I-E (Both banks, front to rear)

#### VALVE GUIDE SERVICING

Valve guides are integral with cylinder head and are not replaceable. Replacement valves are available with .003", .015", and .030" oversize stems.

1) Clean valve guide bore with solvent and a rifle brush. Use a ball gauge and micrometer to measure guide wear. Take measurements of guide crosswise and lengthwise to head, inserting ball gauge 3/8" into guide bore from top of head.

2) Difference between the two measurements is guide bore out-of-round. Ream valve guides if out-of-round measurement exceeds .0025" (.06 mm).

3) If guide measures more than .003" (.08 mm) larger than guide bore diameter listed in specifications, ream valve guide for installation of valve with oversize stem.

4) Always ream valve guides in progressive steps, using reamers in sequence to obtain desired size.

#### VALVE STEM OIL SEALS

Nylon valve stem seals are used on all valves. Replace seals whenever they become deteriorated, or

## 6.0 LITER V8 (Cont.)

valve service is performed. Use a  $\frac{7}{16}$ " deep-well socket and light mallet to seat valve seals onto stems. Ensure sharp edges of valve lock groove do not damage seal during installation.

### VALVE SPRINGS

Although normal service is performed with cylinder head removed, it is possible to replace seals, locks, retainers, or broken springs with cylinder head installed.

#### Removal

1) Remove air cleaner. Remove rocker arm cover. Remove bridge and pivot assemblies, rocker arm, and push rod of valve to be serviced.

2) Remove spark plug and install 14 mm (thread size) air hose adapter into spark plug hole. Connect an air hose to adapter and maintain constant air pressure of at least 90 psi.

3) Using valve spring compressor tool (J-22534 or equivalent), compress valve spring and remove locks. Remove valve spring retainer, valve spring, and oil seal.

#### Inspection

Using valve spring tester, check valve springs for proper tension. Measure free length of valve springs. Replace springs that fail specification.

#### Installation

1) Use a  $\frac{7}{16}$ " deep-well socket and light hammer to gently tap valve stem seal into place on valve stem. Ensure sharp edges of valve lock groove do not damage oil seal during installation. Install valve spring with closed-coil end down, then install retainer.

2) Compress spring with valve spring compressor tool, and install locks. Tap each valve spring from side to side to ensure spring is seated properly. Turn off air supply and remove air hose and adapter. Install remaining components in reverse order of removal.

### HYDRAULIC VALVE LIFTER ASSEMBLY

1) Service lifters as complete assemblies only. Parts are not interchangeable between lifters. Inspect lifter body for signs of scuffing. Inspect base of lifter for concave wear. If concave wear is present, replacement of camshaft and lifters is necessary.

2) Disassemble and clean lifters, then reassemble. See Fig. 2. Using lifter leak-down rate tester and lifter test fluid, test lifter leak down. Compress lifter plunger and record time required for tester needle to align

Fig. 2: Hydraulic Lifter Assembly

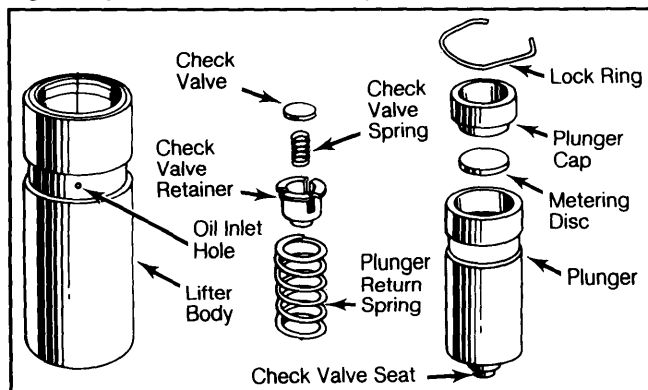

Do not interchange parts between lifters.

with .125" mark on scale. Leak-down rate should be 20-110 seconds.

3) Replace lifters that fail test. Do not attempt to prime lifters with engine oil prior to installation. Lifters will fill with oil within 3-8 minutes of engine operation.

### ROCKER ARM ASSEMBLY

Both intake and exhaust rocker arms for each cylinder pivot on a bridge and pivot assembly. See Fig. 3. The bridge and pivot assembly maintains correct rocker arm-to-valve tip alignment. When removing rocker arm assemblies, always keep parts in order for reinstallation in original locations.

Fig. 3: Rocker Arm Assembly

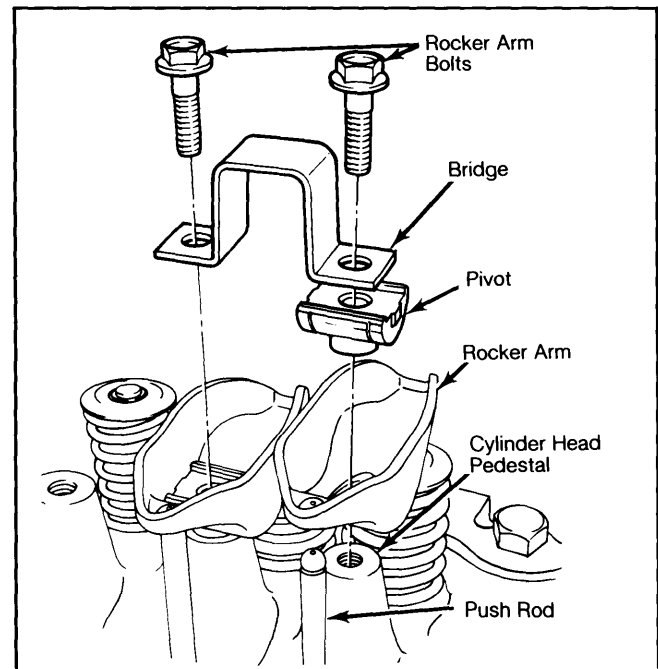

Tighten rocker arm bolts to 19 ft. lbs. (26 N.m).

## PISTONS, PINS & RINGS

### OIL PAN

See Oil Pan Removal at end of ENGINE Section.

### PISTON & ROD ASSEMBLY

#### Removal

1) Remove cylinder heads and oil pan. Position piston at bottom of stroke and cover with a cloth to collect metal cuttings. Using a ridge reamer, remove any ridge or deposits on upper end of cylinder bore.

2) If necessary, mark connecting rods and caps for cylinder identification. Remove connecting rod bearing cap and bearings.

3) Install pieces of rubber hose over connecting rod bolts to protect cylinder walls and crankshaft. Push piston and rod assembly out top of cylinder block and install rod cap on mating rod.

#### Installation

1) Lightly coat piston, rings, and cylinder wall with engine oil. Properly position rings on piston. See Fig. 4. Using ring compressor, compress rings on piston. Ensure position of rings does not change.

# Jeep V8 Engines

## 6.0 LITER V8 (Cont.)

2) Install upper bearing into rod, and cover rod studs with protective rubber hose. Position piston in bore with notches on piston head pointing toward front of engine.

3) Install piston and rod assembly into its respective bore, while guiding connecting rod onto crankshaft journal. Install and tighten rod cap.

### FITTING PISTONS

1) Measure each cylinder bore approximately  $2\frac{5}{16}$ " below top of cylinder bore. Measure each piston 90° to piston pin at centerline of pin. Difference between the two measurements is piston-to-cylinder bore clearance.

2) Using bore gauge or inside micrometer, measure cylinder bore 90° to crankshaft at top of bore, and also at bottom of bore. Taper is the difference between the two measurements.

3) Turn measuring tool 120° and measure at top and bottom of bore. Turn tool another 120° and repeat measurement. Difference between the two measurements is out-of-round.

4) If out-of-round exceeds .003" (.08 mm), or taper exceeds .005" (.13 mm), bore and hone cylinder for installation of oversize piston.

### FITTING RINGS

1) Measure ring side clearance with feeler gauge fitted between ring land and ring. Measure clearance while rotating ring in groove. Ring must not bind in groove.

2) Measure end gap of each compression ring in cylinder bore. Push a ring down into bore, near bottom of ring travel. Ring must be square in bore. Measure ring end gap with feeler gauge.

3) Install rings on piston. See Fig. 4. Install upper and lower rings with gaps positioned 180° apart.

**Fig. 4: Ring Gap Positions and Markings**

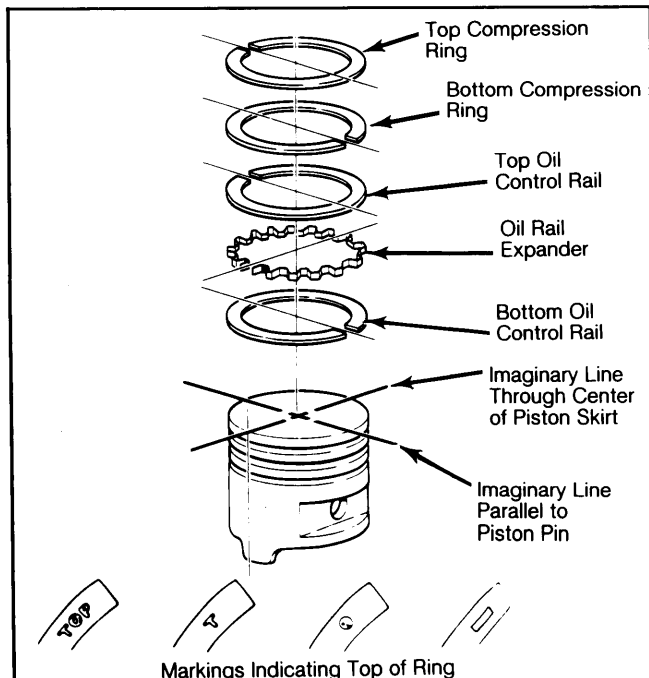

Ring gaps can vary as much as 20° from positions illustrated.

Ensure ring markings (indicating top of ring), point upward.

### PISTON PINS

#### Removal

Using piston pin remover/installer tool and an arbor press, press piston pin out of piston and rod assembly. Discard piston pin.

#### Inspection

To check replacement piston pin for fit, position piston so pin bore is in a vertical position. At room temperature, replacement pin should slide completely through pin bore without using force. If pin jams in bore, replace piston.

#### Installation

1) Assemble connecting rod to piston so that notches on piston head will face forward and connecting rod squirt hole will face inward, when assembly is installed in engine. Use piston pin remover/installer tool and arbor press to press pin through connecting rod and piston.

2) Pin should be centered in connecting rod. The piston pin requires a 2,000 lb. press fit. If little effort is required to install pin in connecting rod, or if rod moves on pin, replace connecting rod.

## CRANKSHAFT & ROD BEARINGS

### MAIN & CONNECTING ROD BEARINGS

**NOTE:** Plastigage method is used for checking bearing clearances. The following procedures are with oil pan removed and oil film removed from surfaces to be checked.

#### Connecting Rod Bearings

1) Undersize bearings of different sizes may be used in combination to achieve desired clearance. Never use a pair of bearings on same journal that differ more than .001" in size. Rod journal size is identified by a color-coded paint mark on adjacent counterweight, toward rear end of crankshaft.

2) Rotate crankshaft to position connecting rod at bottom of stroke. Ensure rod cap is marked for cylinder identification. Remove connecting rod cap. Place strip of Plastigage across full width of lower bearing half, at center of bearing.

3) Install and tighten bearing cap to specification. Do not rotate crankshaft. Remove rod cap and measure width of compressed Plastigage with scale furnished. Install new bearings if clearance is excessive. Lubricate crankshaft and bearing with engine oil prior to installation.

#### Main Bearings

1) Check main bearing clearances one at a time. Use Plastigage method (as explained in Connecting Rod Bearings) to check main bearing clearances, tightening caps to specification.

2) When required, undersize bearings of different sizes may be used in combination to obtain correct bearing clearance. Using this method, ensure that all odd-sized bearings are installed on same side of crankshaft. Never use a pair of bearings that differ more than .001" in size.

3) Main bearing caps are numbered 1 to 5 (front to rear). Main journal size (except rear main) is

## 6.0 LITER V8 (Cont.)

identified in production by a color-coded paint mark on adjacent counterweight toward rear end of crankshaft. Rear main journal has a paint mark on the crankshaft rear flange.

4) To replace main bearings, remove main cap and bearing. Remove bearing from cap. Loosen all other bearing caps. Fabricate a bearing remover/installer tool, using a  $\frac{7}{64}$ " cotter pin. See Fig. 5.

**Fig. 5: Rear Main Bearing Remover/Installer Tool**

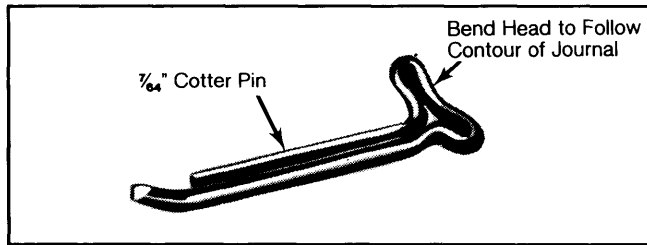

Tool is inserted  $\frac{1}{2}$ " into crankshaft oil hole to aid in bearing removal and installation.

5) Install cotter pin into crankshaft oil hole. Rotate crankshaft in direction of bearing tang slot in block to force bearing out of block.

6) Apply a light film of oil to new upper bearing. Start plain end of bearing into bearing tang side of block. Use cotter pin tool to push upper main bearing into place, by rotating crankshaft in opposite direction of removal.

7) Install remaining bearings using same procedure. Install lower bearings into caps. Install and tighten main caps with arrows pointing toward front of engine.

### THRUST BEARING ALIGNMENT

Before final tightening of No. 3 thrust bearing cap, pry crankshaft forward then rearward to align thrust faces of bearings.

### REAR MAIN BEARING OIL SEAL

#### Removal

Remove oil pan and rear main bearing cap. Loosen remaining main bearing cap bolts. Using a brass drift, tap upper seal around crankshaft until seal protrudes enough to permit removal with pliers. Remove lower seal from bearing cap.

**Fig. 6: Rear Main Bearing Oil Seal Installation**

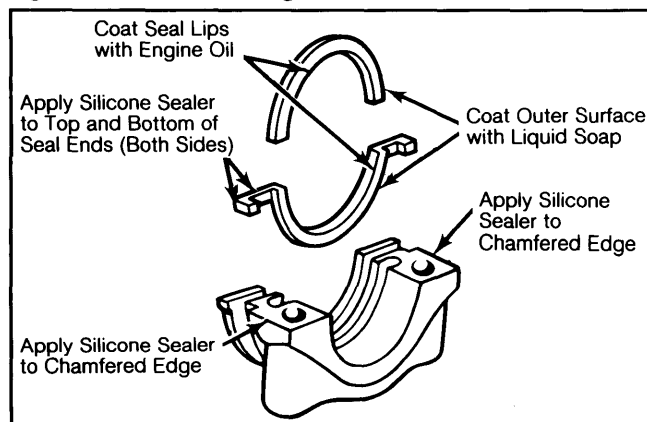

Do not apply sealer to cylinder block mating surface.

#### Installation

1) Clean crankshaft seal surface. Lightly coat lips of new seal halves with engine oil and outer surface of seal case with liquid soap. See Fig. 6. Install upper seal into block with lip facing toward front of engine.

2) Install lower seal into bearing cap with lip facing front. Make sure seal is firmly seated in bearing cap recess. Apply silicone sealer to chamfered edges of bearing cap and to both sides of seal ends. See Fig. 6. Install rear main bearing cap. Tighten all main bearing cap bolts.

## CAMSHAFT

### ENGINE FRONT COVER

#### Removal

1) Drain radiator and cylinder block. Disconnect radiator hoses, heater hose and by-pass hose from manifold and water pump. Remove all drive belts. Remove fan and hub assembly. If A/C equipped, remove compressor and bracket from engine and position aside. Do not disconnect A/C hoses.

2) Remove alternator and mounting bracket. Remove idler pulley. If equipped, remove power steering pump and bracket assembly. Remove air pump and mounting bracket as an assembly, with hoses attached. Remove fuel pump and distributor. Remove crankshaft damper pulley and vibration damper.

3) Remove front oil pan bolts. Remove bolts attaching front cover to cylinder block, noting their lengths and locations for reinstallation in same positions. Remove front cover. Remove front cover lower locating dowel pin from cylinder block.

#### Installation

1) Use sharp tool to cut both sides of oil pan gasket flush with engine block. Using cut pieces as a template, cut and fit replacement gasket pieces from new gasket. Clean all gasket mating surfaces. Install new front oil pan seal to bottom of front cover.

2) Align tabs of replacement oil pan gasket pieces with oil pan seal on front cover and cement into place on bottom of front cover. Apply non-hardening sealer to both sides of front cover gasket and install on front cover. Apply non-hardening sealer to oil pan-to-cylinder block junctions.

3) Place front cover in position on cylinder block and install front oil pan bolts. Tighten bolts slowly and evenly until cover aligns with upper locating dowel pin. Insert lower locating dowel pin through appropriate hole in front cover, and drive pin into cylinder block.

4) Install and tighten remaining front cover bolts. Install remaining components in reverse order of removal. Fill cooling system. Start engine and inspect for oil and coolant leaks.

### FRONT COVER OIL SEAL

#### Removal

Loosen all drive belts. Remove crankshaft pulley and vibration damper. Use oil seal remover tool (J-9256) to remove oil seal.

#### Installation

Clean seal contact surface of vibration damper, then lubricate with engine oil. Apply non-hardening sealer to outer metal case of new seal. Position seal into recess in front cover. Using seal installer tool (J-26562), install front seal. Install remaining components.

# Jeep V8 Engines

## 6.0 LITER V8 (Cont.)

### TIMING CHAIN & SPROCKETS

#### Removal

Remove front cover and oil slinger. Rotate crankshaft until timing marks on sprockets are aligned. Remove camshaft sprocket bolt, washer, distributor drive gear and fuel pump eccentric. Remove timing chain and both sprockets as an assembly.

#### Installation

1) Assemble timing chain over camshaft and crankshaft sprockets with timing marks on sprockets aligned. See Fig. 7. Install chain and sprockets as an assembly. Ensure timing marks on sprockets are aligned.

2) Install remaining components while noting the following: Fuel pump eccentric must be installed with stamped word "REAR" facing camshaft. Camshaft washer fits into recess in distributor drive gear.

**Fig. 7: Timing Chain and Sprocket Alignment**

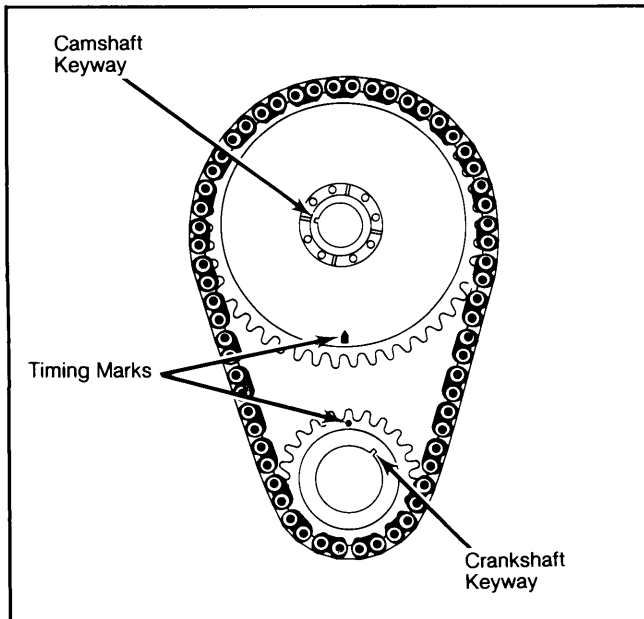

Tighten camshaft sprocket bolt to 30 ft. lbs. (41 N.m).

### CAMSHAFT

#### Removal

1) Drain radiator and cylinder block. Remove radiator. If A/C equipped, remove condenser and receiver assembly as a charged unit. Remove rocker arm covers. Remove bridge and pivot assemblies, rocker arms and push rods in order, for reinstallation in original locations.

2) Remove intake manifold. Remove valve lifters in order for reinstallation in original locations. Remove front cover. Rotate crankshaft to align timing marks on camshaft and crankshaft sprockets.

3) Remove timing chain and sprockets as an assembly. Remove hood latch support bracket. Remove front bumper or grille (as required). Remove camshaft.

#### Installation

To install camshaft, reverse removal procedures while noting the following: Heavily coat camshaft and lifters with an engine oil supplement prior to installation. Fuel pump eccentric must be installed with stamped word "REAR" facing camshaft sprocket. Camshaft washer fits into recess in distributor drive gear. See Fig. 8.

**Fig. 8: Camshaft Assembly**

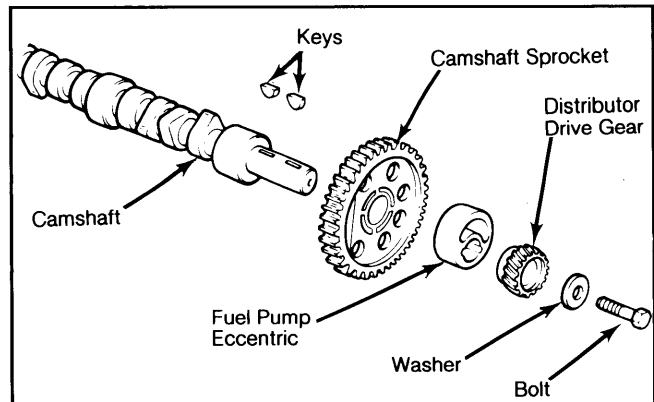

Fuel pump eccentric must be installed with stamped word "REAR" facing camshaft sprocket.

### CAMSHAFT BEARINGS

Remove engine from vehicle to install camshaft bearings. Use screw-type camshaft bearing remover/installer tool (J-21054-1) and proper adapters, to replace camshaft bearings. Do not use a driver-type bearing remover/installer tool. Ensure oil holes in bearings are aligned with oil holes in block.

### CAM LOBE LIFT

1) Remove rocker arm covers and spark plugs. Remove bridge and pivot assemblies and rocker arms in order, for reinstallation in original locations.

2) Using mounting fixture, attach dial indicator to cylinder head so indicator point rests on top of push rod. Use a piece of rubber hose to secure indicator point to end of push rod. Dial indicator point must be in same plane as push rod vertical movement. See Fig. 9.

3) Rotate crankshaft slowly until valve lifter is on base circle of cam lobe. In this position, push rod will be at its lowest travel. Zero dial indicator.

4) Rotate engine until push rod is in fully raised position and record reading. Correct lobe lift is .260-.270" (6.60-6.86 mm). If less than specifications, replace camshaft and lifters. Check remaining cam lobes in same manner.

**Fig. 9: Dial Indicator Installation for Checking Cam Lobe Lift and Valve Timing**

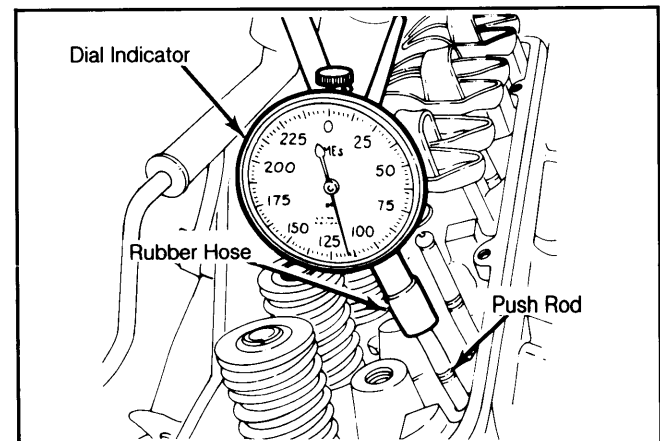

Correct cam lobe lift is .260-.270" (6.60-6.86 mm).

## 6.0 LITER V8 (Cont.)

### VALVE TIMING

1) Remove spark plugs. Remove left rocker arm cover. Remove bridge and pivot assemblies and rocker arms from No. 1 cylinder.

2) Rotate crankshaft until No. 6 piston is on TDC at end of compression stroke. Rotate crankshaft counterclockwise 90° (as viewed from front of engine).

3) Install dial indicator on No. 1 intake valve push rod end. Use rubber hose to secure indicator point to end of push rod. Dial indicator point must be in same plane as push rod vertical movement. Zero dial indicator.

4) Slowly rotate crankshaft in direction of normal rotation until dial indicator shows .020" lift. Timing mark on vibration damper should align with TDC mark on timing scale. If timing mark is off more than 1/2" in either direction, valve timing is incorrect.

### ENGINE OILING

#### Crankcase Capacity

Capacity is 4 quarts (3.8L). Add 1 quart (.95L) when replacing oil filter.

#### Oil Filter

Replace filter every 7500 miles or 7½ months, whichever comes first. Filter is full-flow type, mounted on engine front cover.

#### Normal Oil Pressure

37-75 psi (2.6-5.3 kg/cm<sup>2</sup>) maximum at +1600 RPM. Minimum oil pressure should be 13 psi (.9 kg/cm<sup>2</sup>) at 600 RPM.

#### Pressure Regulator Valve

Located in pump body, not adjustable.

### ENGINE OILING SYSTEM

Oil is forced from a gear-type oil pump to a full-flow oil filter. Oil is directed to right main oil gallery through a passage that extends internally up left front side of cylinder block. A passage that intersects with right main oil gallery directs oil to left main oil gallery.

Right and left main oil galleries directly lubricate lifters. Passages extend down from right oil gallery to lubricate camshaft and crankshaft bearings.

Crankshaft is internally drilled to provide oil to connecting rod bearings and journals. A squirt hole in each connecting rod cap disperses oil to cylinder walls, pistons and piston pins, with each rotation of crankshaft.

Oil routed from front camshaft bearing passes through camshaft sprocket to lubricate timing chain components. Oil from lifters is directed through hollow push rods to lubricate upper valve train area.

### OIL PUMP

#### Removal & Disassembly

Remove retaining bolts and separate oil pump cover, gasket and oil filter as an assembly from pump body (engine front cover). Slide drive gear, idler gear and idler shaft out of pump body. Unscrew oil pressure relief valve cap and remove spring and plunger from pump cover. Thoroughly clean all parts.

#### Inspection

1) The Plastigage method (preferred) or the feeler gauge method (alternate) can be used to measure gear end clearance. Using either method, ensure the pump gears are up into pump body as far as possible, to accurately determine clearance.

2) Using Plastigage method, place strip of Plastigage across full width of each gear. Install pump cover and gasket and tighten to specification. Remove pump cover and measure width of compressed Plastigage with scale furnished.

3) Using feeler gauge method, place straight-edge across gears and pump body. Insert feeler gauge between straightedge and pump body to measure clearance.

4) With gears installed in pump body, insert feeler gauge between gear tooth and inner wall of pump body, directly opposite point of gear mesh. Rotate gears and measure clearance between each gear tooth and pump body in same manner.

5) Check relief valve plunger for wear or binding in pump cover. If wear is apparent or binding occurs, replace pump cover and relief valve plunger.

### OIL PUMP SPECIFICATIONS

Application	Specification In. (mm)
Gear End Clearance	
Plastigage Method .....	.002-.008 (.05-.20)
Feeler Gauge Method .....	.004-.008 (.10-.20)
Gear-to-Body Clearance .....	.0005-.0025 (.013-.064)

#### Reassembly & Installation

Install oil pressure relief valve, spring and retaining cap into pump cover. Install idler shaft, idler gear and drive gear into pump body. Fill gear cavity with petroleum jelly to properly prime pump. Do not use grease of any type. Using new gasket, install and tighten pump cover.

## ENGINE COOLING

### WATER PUMP

#### Removal

1) Disconnect negative battery cable. Drain radiator and remove upper radiator hose. Loosen all drive belts. If equipped with fan shroud, separate shroud from radiator, then install one radiator/shroud bolt to retain radiator in place.

2) Remove fan and hub from water pump. Remove fan and shroud from engine compartment. If A/C equipped, remove mounting stud from water pump that compressor bracket is secured to. Remove alternator and bracket and position aside.

3) If power steering equipped, remove front half of power steering bracket from water pump mounting stud. Disconnect all coolant hoses from water pump. Remove water pump and discard gasket.

#### Installation

Clean all gasket mating surfaces. Check front cover cavity for corrosion. Using new gasket, install and tighten water pump. To complete installation, reverse removal procedures.

**NOTE:** For further information on cooling system capacities and other cooling system components, see appropriate article in "Engine Cooling Systems" in ENGINE Section.

# Jeep V8 Engines

## 6.0 LITER V8 (Cont.)

### ENGINE SPECIFICATIONS

#### GENERAL SPECIFICATIONS

Year	Displ.		Carburetor	HP at RPM	Torque Ft. Lbs.@RPM	Compr. Ratio	Bore		Stroke	
	cu. ins.	liters					in.	mm	in.	mm
1982	360	6.0	2-Bbl.	.....	.....	8.25:1	4.08	103.6	3.44	87.4

#### VALVES

Engine & Valve	Head Diam. In. (mm)	Face Angle	Seat Angle	Seat Width In. (mm)	Stem Diameter In. (mm)	Stem Clearance In. (mm)	Valve Lift In. (mm)
6.0L Int.	2.020-2.030 (51.31-51.56)	29°	30°	.040-.060 (1.02-1.52)	.3715-.3725 (9.44-9.46)	.001-.003 (.03-.08)	.426 (10.82)
Exh.	1.675-1.685 (42.55-42.90)	44°	44.5°	.040-.060 (1.02-1.52)	.3715-.3725 (9.44-9.46)	.001-.003 (.03-.08)	.426 (10.82)

#### PISTONS, PINS, RINGS

Engine	PISTONS	PINS		RINGS		
	Clearance In. (mm)	Piston Fit In. (mm)	Rod Fit In. (mm)	Rings	End Gap In. (mm)	Side Clearance In. (mm)
6.0L	.0012-.0020 (.030-.051)	.0003-.0005 (.008-.013)	Press Fit	1	.010-.020 (.25-.51)	.0015-.0030 (.038-.076)
				2	.010-.020 (.25-.51)	.0015-.0035 (.038-.089)
				3	.015-.045 (.38-1.14)	.000-.007 (.00-.18)

#### CRANKSHAFT MAIN & CONNECTING ROD BEARINGS

Engine	MAIN BEARINGS				CONNECTING ROD BEARINGS		
	Journal Diam. In. (mm)	Clearance In. (mm)	Thrust Bearing	Crankshaft End Play In. (mm)	Journal Diam. In. (mm)	Clearance In. (mm)	Side Play In. (mm)
6.0L	<sup>1</sup> 2.7474-2.7489 (69.784-69.822)	<sup>2</sup> .001-.003 (.03-.08)	No. 3	.003-.008 (.08-.20)	2.0934-2.0955 (53.172-53.226)	.001-.003 (.03-.08)	.006-.018 (.15-.46)

<sup>1</sup> — Rear main journal diameter is 2.7464-2.7479 (69.759-69.797 mm). <sup>2</sup> — Rear main journal clearance is .002-.004 (.05-.10 mm).

#### MAIN BEARING JOURNALS COLOR CODE CHART

Journal Code & Size In. (mm)	Upper Bearing Code & Size	Lower Bearing Code & Size
Yellow ..... 2.7484-2.7489 ..... (69.809-69.822)	Yellow ..... Std. ....	Yellow ..... Std. ....
Orange ..... 2.7479-2.7484 ..... (69.797-69.809)	Yellow ..... Std. ....	Black ..... 1 .001"
Black ..... 2.7474-2.7479 ..... (69.784-69.797)	Black ..... 1 .001"	Black ..... 1 .001"
Green ..... 2.7469-2.7474 ..... (69.771-69.784)	Black ..... 1 .001"	Green ..... 1 .002"
Red ..... 2.7384-2.7389 ..... (69.555-69.568)	Red ..... 1 .010"	Red ..... 1 .010"

<sup>1</sup> — Undersize.

#### ROD BEARING JOURNALS COLOR CODE CHART

Journal Code & Size In. (mm)	Upper Bearing Code & Size	Lower Bearing Code & Size
Yellow ..... 2.0948-2.0955 ..... (53.208-53.226)	Yellow ..... Std. ....	Yellow ..... Std. ....
Orange ..... 2.0941-2.0948 ..... (53.190-53.208)	Yellow ..... Std. ....	Black ..... 1 .001"
Black ..... 2.0934-2.0941 ..... (53.172-53.190)	Black ..... 1 .001"	Black ..... 1 .001"
Red ..... 2.0848-2.0855 ..... (52.954-52.972)	Red ..... 1 .010"	Red ..... 1 .010"

<sup>1</sup> — Undersize.

# Jeep V8 Engines

## 6.0 LITER V8 (Cont.)

### ENGINE SPECIFICATIONS (Cont.)

#### CAMSHAFT

Engine	Journal In. (mm)	Clearance In. (mm)	Lobe Lift In. (mm)
6.0L			
No. 1	2.1195-2.1205 (53.835-53.861)	.001-.003 (.03-.08)	.266 (6.76)
No. 2	2.0895-2.0905 (53.073-53.099)	.001-.003 (.03-.08)	.266 (6.76)
No. 3	2.0595-2.0605 (52.311-52.337)	.001-.003 (.03-.08)	.266 (6.76)
No. 4	2.0295-2.0305 (51.549-51.575)	.001-.003 (.03-.08)	.266 (6.76)
No. 5	1.9995-2.0005 (50.787-50.815)	.001-.003 (.03-.08)	.266 (6.76)

#### VALVE SPRINGS

Engine	Free Length In. (mm)	PRESSURE Lbs. @ In. (kg @ mm)	
		Valve Closed	Valve Open
6.0L	1.99 (50.5)	64-72@1.79 (29-33@45.5)	202-220@1.36 (92-100@34.5)

#### TIGHTENING SPECIFICATIONS

Application	Ft. Lbs. (N.m)
Camshaft Sprocket Bolt .....	30 (41)
Connecting Rod Cap Nuts .....	33 (45)
Cylinder Head Bolts .....	110 (149)
Engine Front Cover Bolts .....	25 (34)
Exhaust Manifold	
2 Center Bolts .....	25 (34)
4 Outer Bolts .....	15 (20)
Flywheel-to-Crankshaft Bolts .....	105 (142)
Intake Manifold Bolts .....	43 (58)
Main Bearing Cap Bolts .....	100 (136)
Oil Pump Cover Bolts .....	5 (7)
Rocker Arm Bolts .....	19 (26)
Vibration Damper Bolt .....	<sup>1</sup> 90 (122)
Water Pump Bolts .....	4 (5)

<sup>1</sup> — Bolt threads clean and lubricated.