

## JEEP — MECHANICAL LINKAGE

All Exc. 4-Cyl. "CJ" & Scrambler

### DESCRIPTION

Clutch assembly includes a dry-disc driven plate and one of two types of clutch covers; a 10½" diameter direct spring type; and an 11" semi-centrifugal type. No internal adjustment for clutch disc wear is needed. Release lever height should be checked and adjusted. Clutch is actuated through mechanical linkage.

### REMOVAL & INSTALLATION

#### CLUTCH

##### Removal

1) Raise and support vehicle under frame. Remove transmission and transfer case (if equipped). Disconnect rod and return spring at clutch fork. Remove release bearing from clutch fork, then remove clutch fork.

2) Mark position of clutch cover on flywheel for reassembly in same position. Install aligning tool (J-5824-01) in clutch disc for support. Loosen clutch plate bolts 1 and 2 turns at a time until clutch plate spring tension is released. Remove clutch pilot tool and remove clutch and disc.

##### Installation

Check all components for wear or damage. Replace as necessary. Using a suitable clutch alignment tool and noting marks made during removal, align clutch disc and loosely install pressure plate. Reverse removal procedure to complete installation.

Fig. 1: Exploded View of Clutch Linkage Assembly Cherokee, Wagoneer and Truck Shown

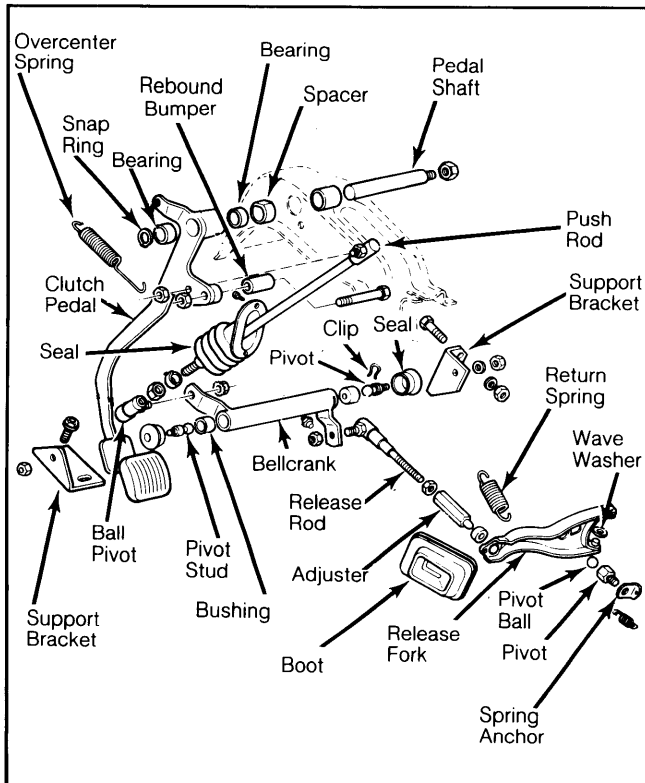

### ADJUSTMENT

#### CLUTCH LINKAGE

Raise clutch pedal up to stop. Adjust lower ball pivot assembly on pedal-to-bellcrank rod until inner bellcrank lever is parallel with front face of clutch housing. Adjust clutch fork release rod to obtain specified pedal free play.

#### CLUTCH PEDAL FREE PLAY

Application	Specification
"CJ" & Scrambler .....	1.0-1.25" (25-31 mm)
All Others .....	.38-.63" (9.5-15.9 mm)

#### CLUTCH RELEASE LEVER

1) Position gauge plate (J-1048) on flywheel. Place clutch cover over gauge plate with release fingers aligned with machined lands on plate. Gauge plate hub should be centered between release levers. Attach cover to flywheel, tightening cover screws one or two turns at a time. Depress each release lever two or three times.

2) Measure height of each lever in relation to plate hub using height gauge tool (J-23330). Tool has four different dimensional settings. Turn adjusting lever nuts until all levers are at correct height. Work levers up and down two or three times and recheck.

#### CLUTCH LEVER RELEASE HEIGHT

Application	Height
"CJ" & Scrambler .....	.09-.11" (2.4-2.8 mm)
All Others .....	.19" (4.7 mm)

Fig. 2: Sectional View Showing Correct Method of Measuring Clutch Release Lever Height

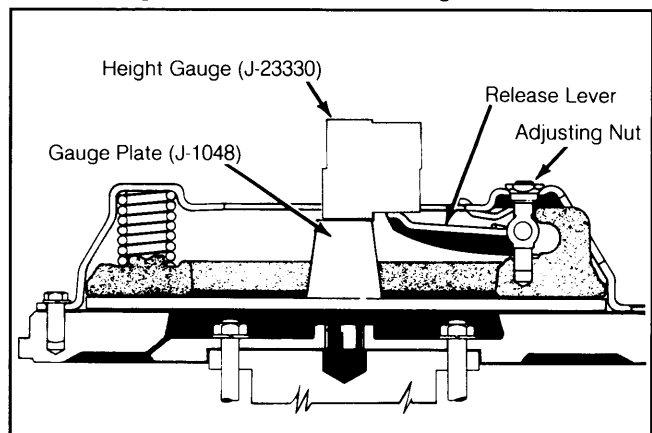

#### TIGHTENING SPECIFICATIONS

Application	Ft. Lbs. (N.m)
Clutch Cover-to-Flywheel Bolts .....	40 (54)
Clutch Housing-to-Engine Bolt	
4-Cyl. ....	54 (73)
6-Cyl. (Top) .....	35 (47)
6-Cyl. (Bottom) .....	45 (61)
V8 .....	30 (41)
Transmission-to-Clutch Housing Bolts .....	55 (74)